

**TSG-RAN Meeting #25  
PALM SPRINGS, CA USA, 7 - 9 September 2004****RP-040381****Agenda Item: 7.1****Source: RAN****Title: Proposed update of Section 5.3.1****Document for: Approval**

---

**5.3 IMT-2000 CDMA TDD****5.3.1 Overview of the radio interface****5.3.1.1 Introduction**

The IMT-2000 radio interface specifications for CDMA TDD technology are developed by a partnership of standards development organizations (SDOs) (see Note 1) and [China Communications Standards Association \(CCSA\)](#) ~~EWTS~~. This radio interface is called the Universal Terrestrial Radio Access (UTRA) time division duplex (TDD), where two options, called 1.28 Mcps TDD (TD-SCDMA - see Note 2) and 3.84 Mcps TDD can be distinguished.

The UTRA TDD specifications have been developed with the strong objective of harmonization with the FDD component (see § 5.1) to achieve maximum commonality. This was achieved by harmonization of important parameters of the physical layer and a common set of protocols in the higher layers are specified for both FDD and TDD, where 1.28 Mcps TDD has significant commonality with 3.84 Mcps TDD. UTRA TDD with the two options accommodates the various needs of the different Regions in a flexible way and is specified in a common set of specifications.

In the development of this radio interface the core network specifications are based on an evolved GSM-MAP. However, the specifications include the necessary capabilities for operation with an evolved ANSI-41-based core network.

The radio access scheme is direct-sequence code division multiple access. There are two chip rate options: the 3.84 Mcps TDD option, with information spread over approximately 5 MHz bandwidth and a chip rate of 3.84 Mchip/s and the 1.28 Mcps TDD option, with information spread over approximately 1.6 MHz bandwidth and a chip rate of 1.28 Mchip/s. The radio interface is defined to carry a wide range of services to efficiently support both circuit-switched services (e.g. PSTN- and ISDN-based networks) as well as packet-switched services (e.g. IP-based networks). A flexible radio protocol has been designed where several different services such as speech, data and multimedia can simultaneously be used by a user and multiplexed on a single carrier. The defined radio bearer services provide support for both real-time and non-real-time services by employing transparent and/or non-transparent data transport. The QoS can be adjusted in terms such as delay, BER and FER.

The radio-interface specification includes enhanced features for High-Speed Downlink Packet Access (HSDPA), allowing for downlink packet-data transmission with peak data rates exceeding 8 Mbps and simultaneous high-speed packet data and other services such as speech on the single carrier.

The radio access network architecture also provides support for Multimedia Broadcast and Multicast Services, i.e. allowing for multimedia content distribution to groups of users over a point-to-multipoint bearer.

NOTE 1 – Currently, these specifications are developed within the third generation partnership project (3GPP) where the participating SDOs are ARIB, [ATIS](#), CCSA, ETSI, ~~TTT~~, TTA and TTC.

NOTE 2 – The same name TD-SCDMA was previously used for one of the original proposals that was further refined following the harmonisation process.

### 5.3.1.2 Radio access network architecture

The overall architecture of the radio access network is shown in Fig. 24.

The architecture of the radio access network consists of a set of radio network subsystems (RNS) connected to the core network through the  $I_{u}$  interface.

An RNS consists of a radio network controller (RNC) and one or more entities called Node B. The Node B is connected to the RNC through the  $I_{ub}$  interface. Node B can handle one or more cells.

The RNC is responsible for the handover decisions that require signalling to the user equipment (UE).

The RNCs of the RNS can be interconnected together through the  $I_{ur}$  interface.  $I_{u}$  and  $I_{ur}$  are logical interfaces, i.e. the  $I_{ur}$  interface can be conveyed over a direct physical connection between RNCs or via any suitable transport network.

Figure 25 shows the radio interface protocol architecture for the radio access network. On a general level, the protocol architecture is similar to the current ITU-R protocol architecture as described in Recommendation ITU-R M.1035. Layer 2 (L2) is split into the following sub-layers; RLC, MAC, Packet Data Convergence Protocol (PDCP) and Broadcast/Multicast Control (BMC). Layer 3 (L3) and RLC are divided into Control (C-) and User (U-) planes.

In the C-plane, L3 is partitioned into sub-layers where the lowest sub-layer, denoted as RRC, interfaces with L2. The higher layer signalling such as MM and CC are assumed to belong to the core network. There are no L3 elements in UTRAN for the U-plane.

FIGURE 24

### Radio Access Network Architecture (Cells are indicated by ellipses)

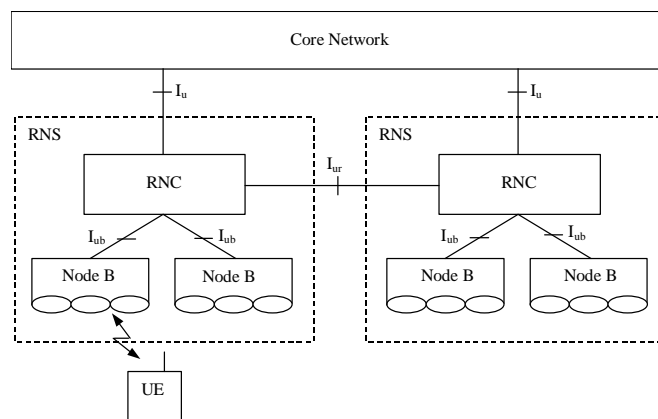
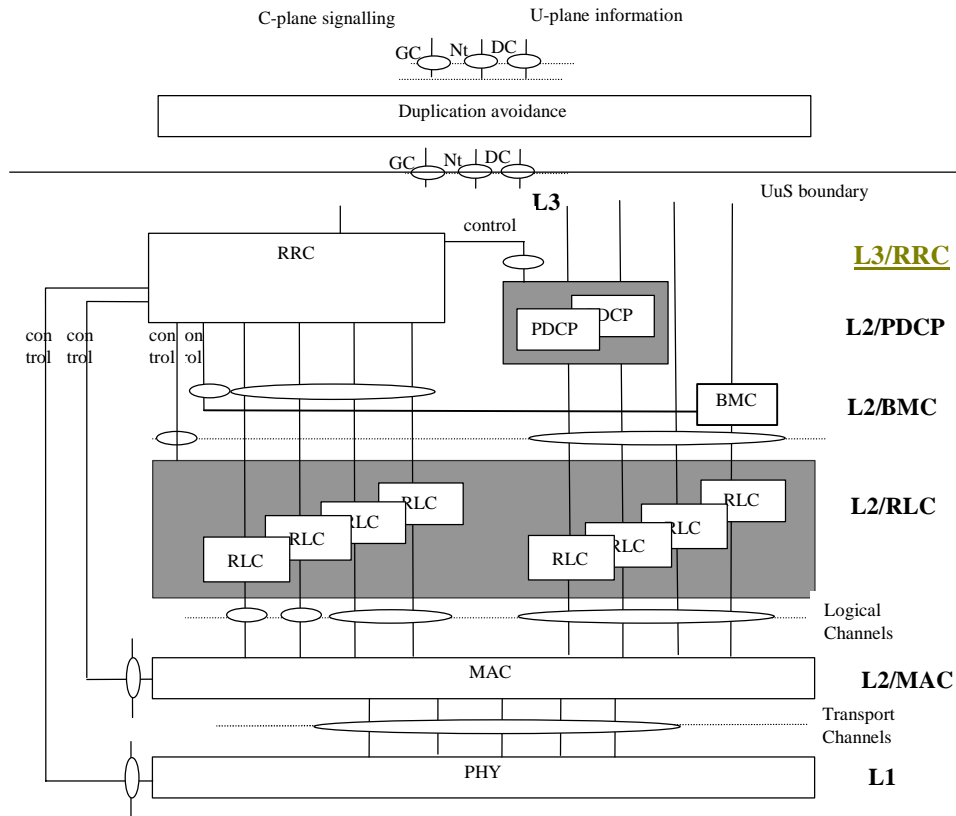


FIGURE 25  
Radio interface protocol architecture of the RRC sublayer L2 and L1



Each block in Fig. 25 represents an instance of the respective protocol. Service access points (SAPs) for peer-to-peer communication are marked with circles at the interface between sub-layers.

The SAP between MAC and the physical layer provides the transport channels. A transport channel is characterized by how the information is transferred over the radio interface (see Sections 5.3.1.3.1.2 and 5.3.1.3.2.2 for an overview of the types of transport channels defined).

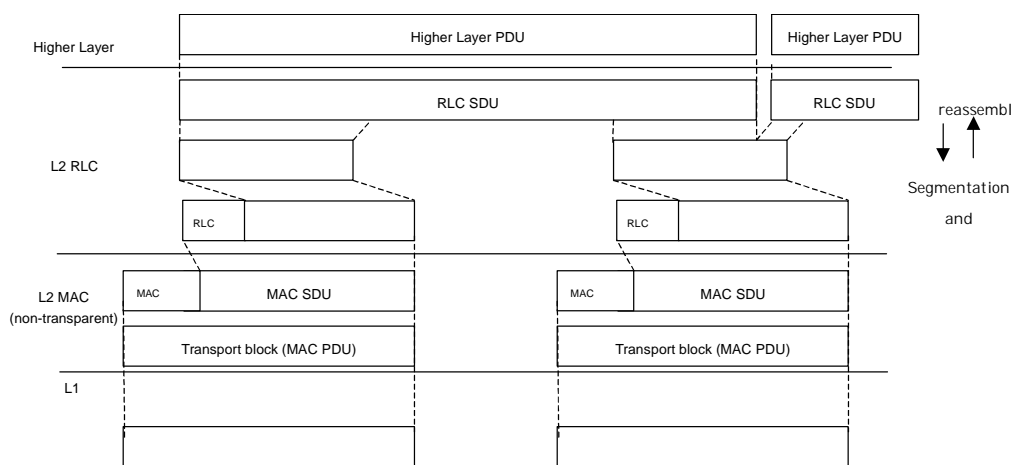
The SAPs between RLC and the MAC sub-layer provide the logical channels. A logical channel is characterized by the type of information that is transferred over the radio interface. The logical channels are divided into control channels and traffic channels. The different types of logical channels are not further described in this overview. The physical layer generates the physical channels that will be transmitted over the air. The physical channel in each TDD option (1.28 Mcps, 3.84 Mcps) is defined by carrier frequency, code, time slot and multi-frame information. In the C-plane, the interface between RRC and higher L3 sub-layers (CC, MM) is defined by the GC, Nt and DC SAPs. These SAPs are not further discussed in this overview.

Also shown in the Figure are connections between RRC and MAC as well as RRC and L1 providing local inter-layer control services (including measurement results). An equivalent control interface exists between RRC and the RLC sub-layer. These interfaces allow the RRC to control the configuration of the lower layers. For this purpose separate control SAPs are defined between RRC and each lower layer (RLC, MAC, and L1).

Figure 26 shows the general structure and some additional terminology definitions of the channel formats at the various sub-layer interfaces indicated in Fig. 25. The Figure indicates how higher layer SDUs and PDUs are segmented and multiplexed to transport blocks to be further treated by the physical layer (e.g. CRC handling). The transmission chain of the physical layer is exemplified in the next section.

FIGURE 26

**Data flow for a service using a non-transparent RLC and non-transparent MAC**  
(see Sections 5.3.1.4.1-2 for further definitions of the MAC and RLC services and functionality)



### 5.3.1.3 Physical layer

#### 5.3.1.3.1 UTRA TDD (3.84 Mcps TDD option)

##### 5.3.1.3.1.1 Physical layer functionality and building blocks

The physical layer includes the following functionality:

- Error detection on transport channels and indication to higher layers.
- FEC encoding/decoding of transport channels.
- Multiplexing of transport channels and demultiplexing of coded composite transport channels.
- Rate matching (data multiplexed on dedicated and shared channels).
- Mapping of coded composite transport channels on physical channels.
- Modulation and demodulation of physical channels.
- Spreading and despreading of physical channels.
- Radio characteristics measurements including FER, Signal-to-Interference (SIR), Interference Power Level etc., and indication to higher layers.
- Frequency and time (chip, bit, slot, frame) synchronization.
- Power weighting and combining of physical channels.

- Closed-loop power control for downlink.
- RF processing.
- Support of UE positioning methods.
- Beamforming.
- Support of timing advance on uplink channels.
- Support of a Node B synchronization method over the air.

Figure 27 gives the physical layer transmission chain for the user plane data, i.e. from the level of transport channels down to the level of physical channel. The Figure shows how several transport channels can be multiplexed onto one or more DPDCH.

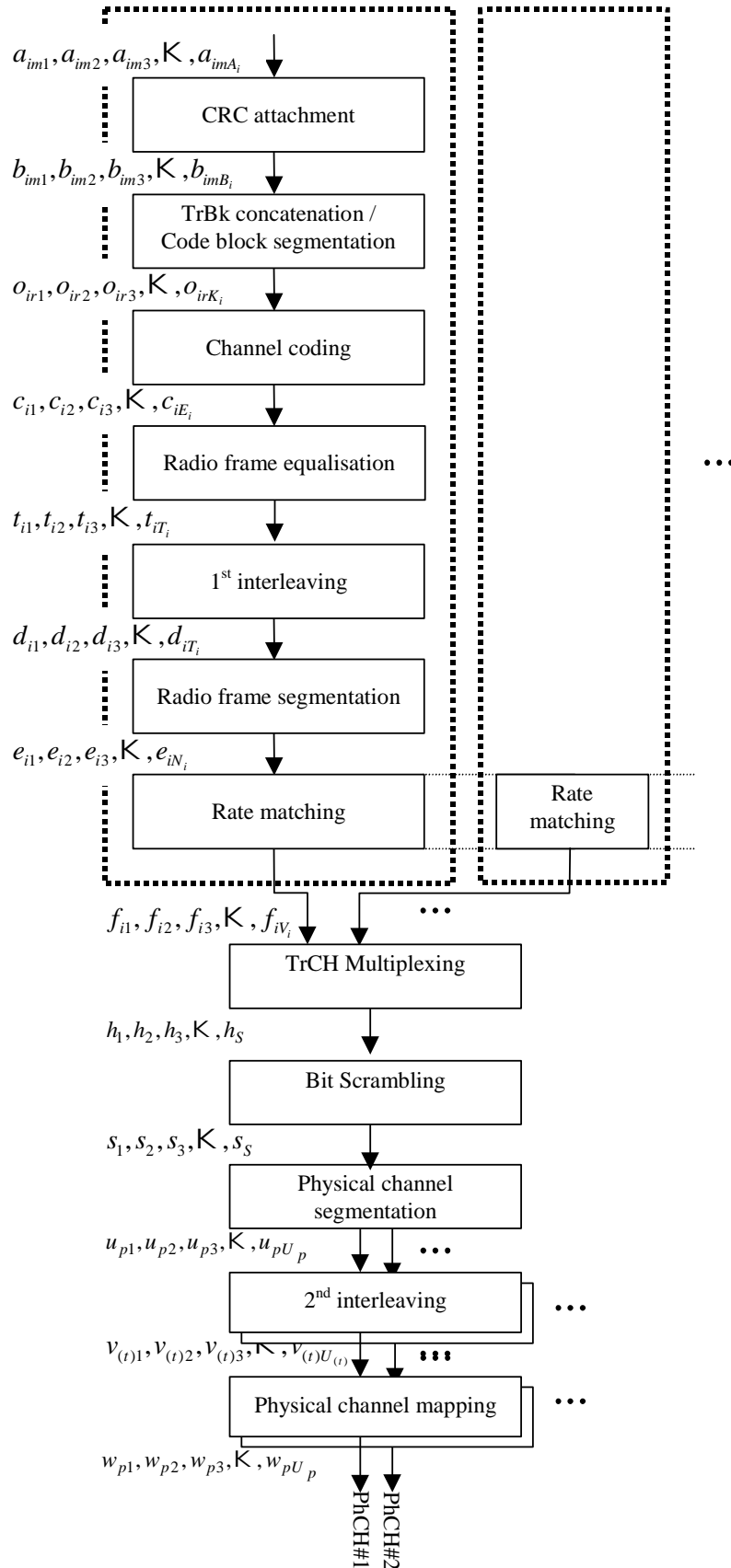
The CRC provides for error detection of the transport blocks for the particular transport channel. The CRC can take the length zero (no CRC), 8, 12, 16 or 24 bits depending on the service requirements.

The transport block concatenation and code block segmentation functionality performs serial concatenation of those transport blocks that will be sent in one transmission time interval and any code block segmentation if necessary.

The types of channel coding defined are convolutional coding, turbo coding and no coding. Real-time services use only FEC encoding while non-real-time services uses a combination of FEC and ARQ. The ARQ functionality resides in the RLC sub-layer of Layer 2. The convolutional coding rates are 1/2 or 1/3 while the rate is 1/3 for turbo codes.

The possible interleaving depths are 10, 20, 40 or 80 ms.

FIGURE 27  
Transport channel multiplexing structure



The radio frame segmentation performs padding of bits. The rate matching adapts any remaining differences of the bit rate so the number of outgoing bits fit to the available bit rates of the physical channels. Repetition coding and/or puncturing is used for this purpose.

The TrCH multiplexing stage combines transport channels in a serial fashion. This is done every 10 ms. The output of this operation is also called coded composite transport channels.

If several physical channels will be used to transmit the data, the split is made in the physical channel segmentation unit.

### 5.3.1.3.1.2 Transport channels

The interface to the MAC sub-layer is the transport channels, see Fig. 25. The transport channels define how and with which type of characteristics the data is transferred by the physical layer. They are categorized into dedicated channels or common channels where many UEs are sharing the latter type. Introducing an information field containing the address then does the address resolution, if needed. The physical channel itself defines a dedicated channel. Thus no specific address is needed for the UE. Table 2 summarizes the different types of available transport channels.

TABLE 2  
The defined transport channels

Transport channel	Type and direction	Used for
DCH (Dedicated channel)	Dedicated; uplink and downlink	User or control information to a UE (entire cell or part of cell (lobe-forming))
BCH (Broadcast channel)	Common; downlink	Broadcast system and cell specific information
FACH (Forward access channel)	Common; downlink	Control information when system knows UE location or short user packets to a UE
PCH (Paging channel)	Common; downlink	Control information to UEs when good sleep mode properties are needed, e.g. idle mode operation
RACH (Random access channel)	Common; uplink	Control information or short user packets from an UE
USCH (Uplink shared channel)	Common; uplink	Carries dedicated user data and control information using a shared channel
DSCH (Downlink shared channel)	Common; downlink	Carries dedicated user data and control information using a shared channel.
HS-DSCH (High Speed Downlink shared channel)	Common; downlink	A downlink channel serving several UEs carrying dedicated control or traffic data. HS-DSCH offers the possibility for high-speed downlink packet access through the support of higher-order modulation, adaptive modulation and coding, fast channel-dependent scheduling, and hybrid ARQ with soft combining

The RACH on the uplink is contention-based while the DCH is reservation-based.

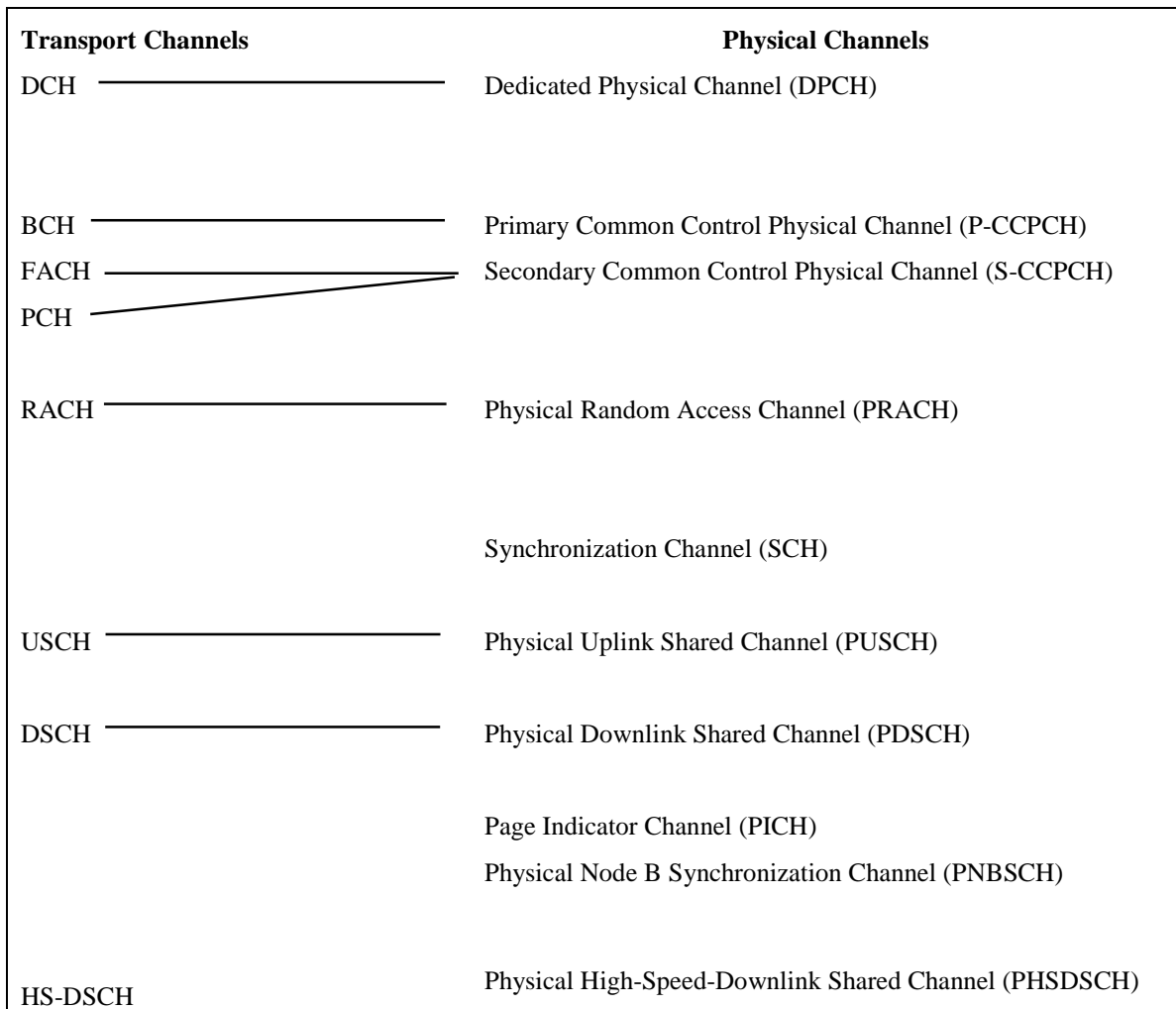
On each transport channel, a number of *Transport Blocks* are delivered to/from the physical layer once every *Transmission Time Interval* (TTI). To each transport channel, there is an associated *Transport Format* or set of transport formats. The transport format describes the physical properties of the transport channel, such as the TTI, the number of transport blocks per TTI, the number of bits per transport blocks, the coding scheme and coding rate, and the modulation scheme.

### 5.3.1.3.1.3 Transport channels to physical channel mapping

The transport channels are mapped onto the physical channels and Fig. 28 shows the different physical channels and summarizes the mapping of transport channels onto physical channels. Each physical channel has its tailored slot content. The DCH is shown in § 5.3.1.3.1.4.

FIGURE 28

### Transport channels, physical channels and their mapping

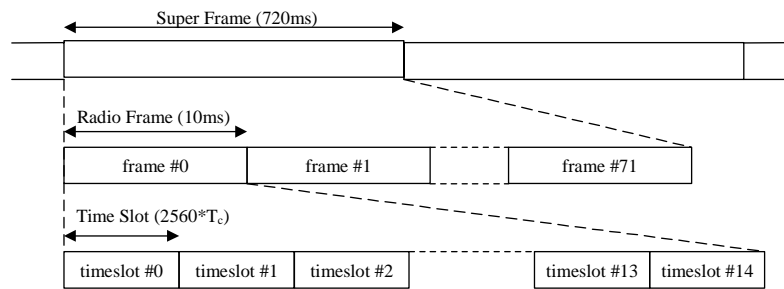




**5.3.1.3.1.4 Physical frame structure**

The basic physical frame rate is 10 ms with 15 slots. Fig. 29 shows the frame structure.

**FIGURE 29  
Basic frame structure**



Each 10 ms frame consists of 15 time slots, each allocated to either the uplink or the downlink. With such a flexibility, this radio interface can be adapted to different environments and deployment scenarios. In any configuration at least one time slot has to be allocated for the downlink and at least one time slot has to be allocated for the uplink.

Figures 30, 31 and 32 show the three burst formats stating the content for a slot used by a DCH. The usage of either burst format 1, 2 or 3 is depending on the application for UL or DL type 3 for uplink only) and the number of allocated users per time slot.

**FIGURE 30  
Burst structure of the burst type 1  
(GP denotes the guard period and CP the chip periods)**

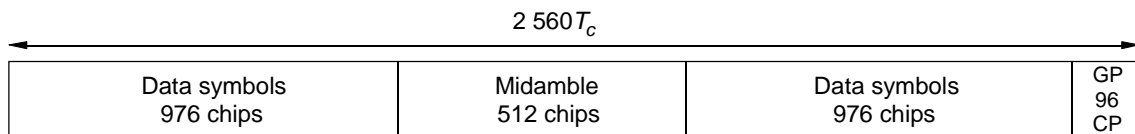
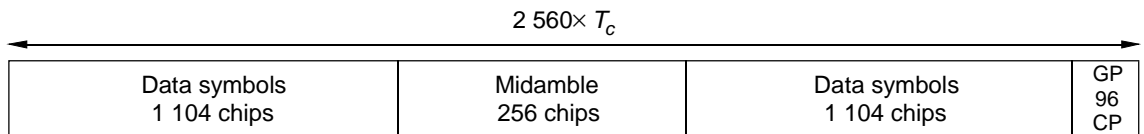


FIGURE 31

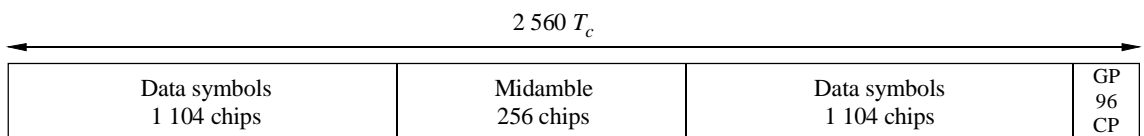
**Burst structure of the burst type 2**  
(GP denotes the guard period and CP the chip periods)



1457-33

FIGURE 32

**Burst structure of the burst type 2**  
(GP denotes the guard period and CP the chip periods)



1457-32

In both cases data bits on the DPCH are QPSK modulated and the resulting symbols are spread with a channelization code of length 1 to 16 (for the DL, only 1 and 16 apply). Due to this variable spreading factor, each burst provides the number of symbols as shown in Table 3.

TABLE 3

**Number of data symbols in TDD bursts in 3.84 Mcps TDD option**

Spreading factor, $Q$	Number of symbols, $N$ , for Burst type 1	Number of symbols, $N$ , for Burst type 2	Number of symbols ( $N$ ) for Burst type 3
1	1952	2208	1856
2	976	1104	928
4	488	552	464
8	244	276	232
16	122	138	116

Thus, the number of bits per TDD burst in 3.84 Mcps TDD option is two times the number shown in Table 3. Usage of multicode and multiple time slots can be applied.

#### 5.3.1.3.1.5 Spreading, modulation and pulse shaping

Spreading is applied after modulation and before pulse shaping. It consists of two operations. The first is the channelization operation, which transforms every data symbol into a number of chips, thus increasing the bandwidth of the signal. The number of chips per data symbol is called the spreading factor (SF) and is in the range of 1 to 16. The second operation is the scrambling operation, where a scrambling code is applied to the spread signal. This procedure is similar to the

radio interface specified in § 5.1, but it should be noted that the midamble part in TDD bursts (see Figs. 30, 31 and 32) is not spread.

The applied channelization codes are OVFSF-codes that preserve the distinguishability of different users. The applied scrambling code is cell-specific and 128 different scrambling codes are available.

In the uplink, the applied midamble is user specific and derived from a cell-specific basic midamble sequence. In the downlink, the applied midamble is either user specific, code specific (default) or common for the whole cell. In each case 128 different basic midamble sequences are available.

After spreading the same pulse-shaping is applied as in FDD mode, i.e. the filters are root-raised cosine with roll-off  $\alpha = 0.22$  in the frequency domain.

Downlink spreading for downlink physical channels other than the downlink DPCH is very similar. For the physical channel to which HS-DSCH is mapped, higher-order data modulation can be used in addition to QPSK.

### 5.3.1.3.2 UTRA TDD (1.28 Mcps TDD option)

#### 5.3.1.3.2.1 Physical layer functionality and building blocks

The physical layer includes the following functionality:

- Error detection on transport channels and indication to higher layers
- Forward Error Control (FEC) encoding/decoding of transport channels.
- Multiplexing of transport channels and demultiplexing of coded composite transport channels.
- Rate matching (data multiplexed on Dedicated and Shared Channels)
- Mapping of coded composite transport channels on physical channels.
- Modulation and demodulation of physical channels.
- Spreading and despreading of physical channels
- Radio characteristics measurements including FER, SIR, DOA, timing advance, handover measurements, etc.
- Frequency and time (chip, bit, time slot, subframe) synchronization.
- Power weighting and combining of physical channels
- Power control.
- Radio Frequency (RF) processing
- UE location/positioning (Smart antenna)
- Beamforming for both uplink and downlink (Smart antenna)
- Macrodiversity distribution/combining and handover execution
- Uplink synchronization
- Random access process.
- Subframe segmentation

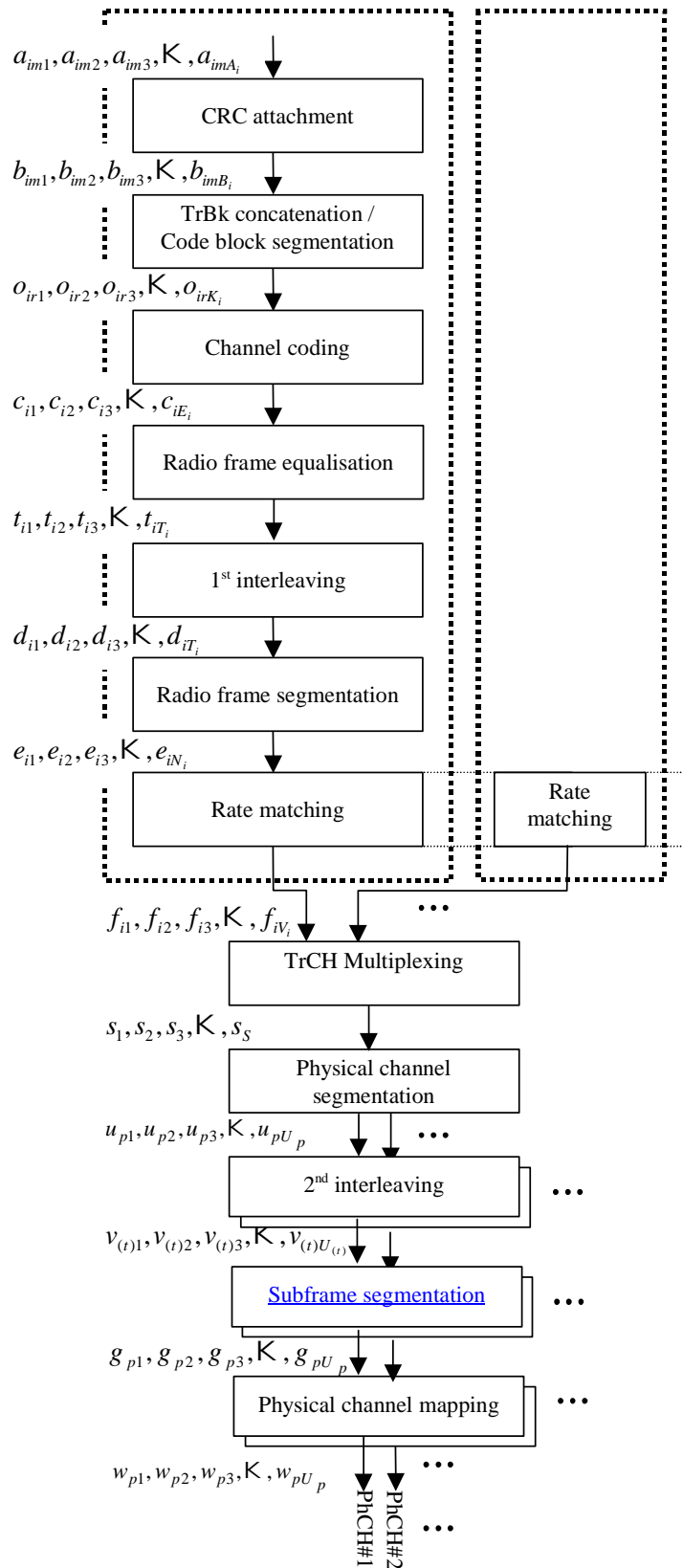
Figure 33 gives the physical layer transmission chain for the user plane data, i.e. from the level of transport channels down to the level of physical channel. Figure 33 shows how several transport channels can be multiplexed onto one or more dedicated physical channels (DPCH).

The CRC provides for error detection of the transport blocks for the particular transport channel. The CRC can take the length zero (no CRC), 8, 12, 16 or 24 bits depending on the service requirements.

The transport block concatenation and code block segmentation functionality performs serial concatenation of those transport blocks that will be sent in one transmission time interval and any code block segmentation if necessary.

The types of channel coding defined are convolutional coding, turbo coding and no coding. Real-time services use only FEC encoding while non-real-time services uses a combination of FEC and ARQ. The ARQ functionality resides in the RLC sub-layer of Layer 2. The convolutional coding rates are 1/2 or 1/3 while the rate is 1/3 for turbo codes.

FIGURE 33  
Transport channel multiplexing structure



The possible interleaving depths are 10, 20, 40 or 80 ms, for the RACH also 5 ms may apply.

The radio frame equalization performs padding of bits. The rate matching adapts any remaining differences of the bit rate so the number of outgoing bits fit to the available bit rates of the physical channels. Repetition coding and/or puncturing is used for this purpose.

The TrCH multiplexing stage combines transport channels in a serial fashion. This is done every 10 ms. The output of this operation is also called coded composite transport channels.

If several physical channels will be used to transmit the data, the split is made in the physical channel segmentation unit.

### 5.3.1.3.2.2 Transport channels

The interface to the MAC sub-layer is the transport channels, see Fig. 25. The transport channels define how and with which type of characteristics the data is transferred by the physical layer. They are categorized into DCH or common channels where many UEs are sharing the latter type. Introducing an information field containing the address then does the address resolution, if needed. The physical channel itself defines a DCH. Thus no specific address is needed for the UE. Table 4 summarizes the different types of available transport channels.

The RACH on the uplink is contention-based while the DCH is reservation-based.

On each transport channel, a number of *Transport Blocks* are delivered to/from the physical layer once every *Transmission Time Interval (TTI)*. To each transport channel, there is an associated *Transport Format* or set of transport formats. The transport format describes the physical properties of the transport channel, such as the TTI, the number of transport blocks per TTI, the number of bits per transport blocks, the coding scheme and coding rate, and the modulation scheme.

### 5.3.1.3.2.3 Transport channels to physical channel mapping

The transport channels are mapped onto the physical channels and Fig. 34 shows the different physical channels and summarizes the mapping of transport channels onto physical channels. Each physical channel has its tailored slot content. The DCH is shown in § 5.3.1.3.2.4.

### 5.3.1.3.2.4 Frame structure

Physical channels take four-layer structure of multi-frames, radio frames, sub-frames and time slots/codes as shown in Fig. 35. The radio frame has a duration of 10 ms and is subdivided into 2 sub-frames of 5 ms each, and each sub-frame is then subdivided into 7 traffic time slots of 675  $\mu$ s duration each and 3 special time slots: DwPTS (downlink pilot timeslot), GP (guard period) and UpPTS (uplink pilot timeslot).

TABLE 4

### The defined transport channels

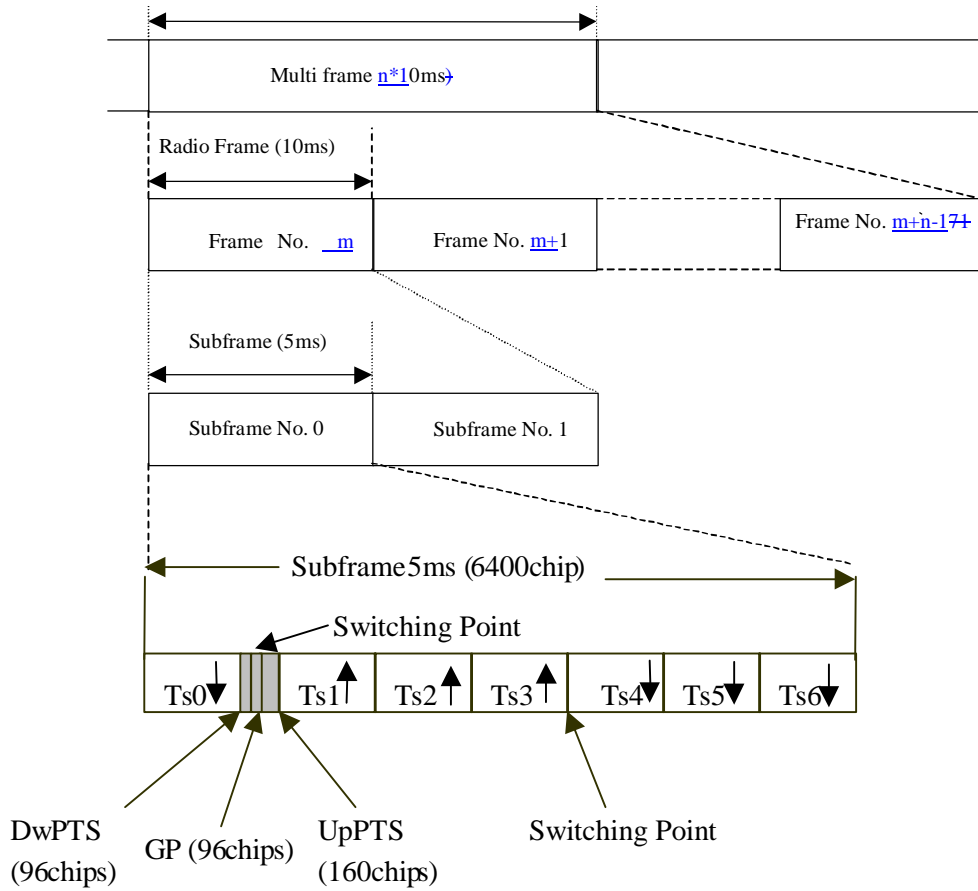
<b>Transport channel</b>	<b>Type and direction</b>	<b>Used for</b>
DCH (dedicated channel)	Dedicated; uplink and downlink	User or control information to a UE (entire cell or part of cell (lobe-forming))
BCH (broadcast channel)	Common; downlink	Broadcast system and cell specific information
FACH (forward access channel)	Common; downlink	Control information when system knows UE location or short user packets to a UE
PCH (paging channel)	Common; downlink	Control information to UEs when good sleep mode properties are needed, e.g. idle mode operation
RACH (random access channel)	Common; uplink	Control information or short user packets from an UE
DSCH (downlink shared channel)	Common; downlink	Carries dedicated user data and control information using a shared channel
HS-DSCH (High Speed Downlink shared channel)	Common; downlink	A downlink channel serving several Ues carrying dedicated control or traffic data. HS-DSCH offers the possibility for high-speed downlink packet access through the support of higher-order modulation, adaptive modulation and coding, fast channel-dependent scheduling, and hybrid ARQ with soft combining.
USCH (uplink shared channel)	Common; uplink	Carries dedicated user data and control information using a shared channel

FIGURE 34  
**Transport channel, physical channel and their mapping**

Transport channels	Physical channels
DCH	Dedicated Physical Channel (DPCH)
BCH	Primary Common Control Physical Channels (P-CCPCH)
PCH	Secondary Common Control Physical Channels(S-CCPCH)
FACH	Secondary Common Control Physical Channels(S-CCPCH)
RACH	Physical Random Access Channel (PRACH)
USCH	Physical Uplink Shared Channel (PUSCH)
DSCH	Physical Downlink Shared Channel (PDSCH)
HS-DSCH	Physical High-Speed-Downlink Shared Channel (PHSDSCH)
	Down link Pilot Channel (DwPCH)
	Up link Pilot Channel (UpPCH)
	Fast Physical Access Channel (FPACH)
	Paging Indicator Channel (PICH)

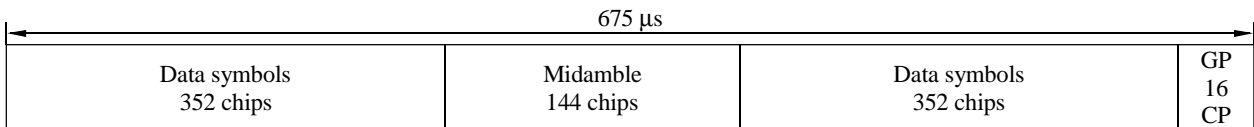


FIGURE 35  
Frame and burst structure



The burst structure is shown in Fig. 37. The burst type consist of two data symbol fields, a midamble of 144 chips and a guard period of 16 chips. The data fields of the burst type are 704 chips long. The data bits in the burst are QPSK modulated and are spread by the spreading factor of 1 to 16 in the UL and with the spreading factors 1 or 16 in the DL. The guard period is 16 chips long. 8PSK modulation may optionally be applied.

FIGURE 37  
Burst struture



1457-37

The corresponding number of symbols depends on the spreading factor as indicated in Table 5.

TABLE 5

**Number of data symbols in one burst with different SF in the 1.28 Mcps TDD option**

Spreading factor, $Q$	Number of symbols, $N$ , per data field in the burst
1	352
2	176
4	88
8	44
16	22

**5.3.1.3.2.5 Spreading, modulation and pulse shaping**

Spreading is applied after modulation and before pulse shaping. It consists of two operations. The first is the channelization operation, which transforms every data symbol into a number of chips, thus increasing the bandwidth of the signal. The number of chips per data symbol is called the SF and is in the range of 1 to 16. The second operation is the scrambling operation, where a scrambling code is applied to the spread signal. It should be noted that the midamble part in TDD bursts is not spread.

The applied channelization codes are OVSF-codes that preserve the distinguishability of different users. The applied scrambling code is cell-specific.

In the uplink, the applied midamble is user specific and derived from a cell-specific basic midamble sequence. In the downlink, the applied midamble is either user specific, code specific (default) or common for the whole cell.

After spreading, pulse-shaping is applied, i.e. the filters are root-raised cosine with roll-off  $\alpha = 0.22$  in the frequency domain.

Downlink spreading for downlink physical channels other than the downlink DPCH is very similar. For the physical channel to which HS-DSCH is mapped, higher-order data modulation can be used in addition to QPSK.

**5.3.1.3.2.6 Transmission and reception**

The frequency bands assumed for operation are unpaired frequency bands at 2 GHz. Also the system can work in other frequency bands available. Several Tx power classes for UE are being defined currently.

**5.3.1.4 Layer 2****5.3.1.4.1 MAC layer**

The MAC sub-layer is responsible for the handling of the data streams coming from the RLC and RRC sub-layers. It provides an unacknowledged transfer mode service to the upper layers. The interface to the RLC sub-layer is through logical channel service access points. It also re-allocates radio resources on request by the RRC sub-layer as well as provides measurements to the upper layers. The logical channels are divided into control channels and traffic channels. Thus, the functionality handles issues like:

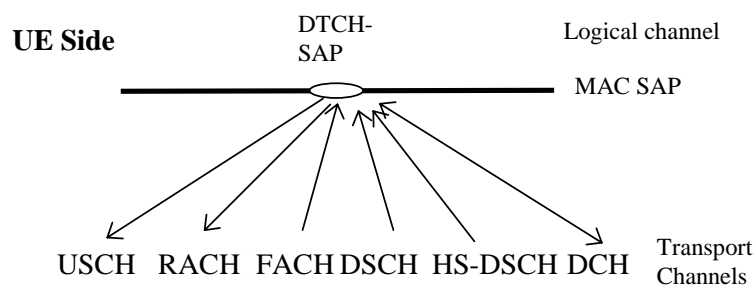
- mapping of the different logical channels to the appropriate transport channels, selection of appropriate transport format for the transport channels based on the instantaneous source bit rate, and optimization of the HS-DSCH transport channel.

- Multiplexing/ demultiplexing of the PDUs to/from transport blocks which are thereafter further treated by the physical layer;
- Dynamic switching between common and dedicated transport channels based on information from the RRC sub-layer;
- Priority issues for services to one UE according to information from higher layers and physical layer (e.g. available transmit power level) as well as priority handling between UEs by means of dynamic scheduling in order to increase spectrum efficiency;
- Monitoring of traffic volume that can be used by the RRC sub-layer;
- Hybrid ARQ with soft combining in case of the HS-DSCH transport channel.

Figure 38 shows the possibilities of mapping the logical channel DTCH onto transport channels. There are possibilities to map onto common transport channels as well as dedicated transport channels. The choice of mapping could be determined on e.g. amount of traffic a user creates.

FIGURE 38

**The possible transport channel mappings of the dedicated traffic channel (DTCH)**  
**(The arrows shows the direction of the channel (UE side);**  
**the directions are reversed from the network side)**



#### 5.3.1.4.2 RLC sub-layer

The RLC sub-layer provides three different types of data transfer modes:

- *Transparent data transfer* – This service transmits higher layer PDUs without adding any protocol information, possibly including segmentation/reassemble functionality.
- *Unacknowledged data transfer* – This service transmits higher layer PDUs without guaranteeing delivery to the peer entity. The unacknowledged data transfer mode has the following characteristics:
  - Detection of erroneous data: The RLC sub-layer shall deliver only those SDUs to the receiving higher layer that are free of transmission errors by using the sequence-number check function.
  - Unique delivery: The RLC sub-layer shall deliver each SDU only once to the receiving upper layer using duplication detection function.
  - Immediate delivery: The receiving RLC sub-layer entity shall deliver a SDU to the higher layer receiving entity as soon as it arrives at the receiver.
- *Acknowledged data transfer* – This service transmits higher layer PDUs and guarantees delivery to the peer entity. In case RLC is unable to deliver the data correctly, the user of RLC at the transmitting side is notified. For this service, both in-sequence and out-of-sequence delivery are supported. In many cases a higher layer protocol can restore the order of its PDUs. As long as the out-of-sequence properties of the lower layer are known and

controlled (i.e. the higher layer protocol will not immediately request retransmission of a missing PDU) allowing out-of-sequence delivery can save memory space in the receiving RLC. The acknowledged data transfer mode has the following characteristics:

- Error-free delivery: Error-free delivery is ensured by means of retransmission. The receiving RLC entity delivers only error-free SDUs to the higher layer.
- Unique delivery: The RLC sub-layer shall deliver each SDU only once to the receiving upper layer using duplication detection function.
- In-sequence delivery: RLC sub-layer shall provide support for in-order delivery of SDUs, i.e. RLC sub-layer should deliver SDUs to the receiving higher layer entity in the same order as the transmitting higher layer entity submits them to the RLC sub-layer.
- Out-of-sequence delivery: Alternatively to in-sequence delivery, it shall also be possible to allow that the receiving RLC entity delivers SDUs to higher layer in different order than submitted to RLC sub-layer at the transmitting side.

It also provides for RLC connection establishment/release. As well as QoS setting and notification to higher layers in case of unrecoverable errors.

An example of the data flow for non-transparent (acknowledged/unacknowledged) data transfer is shown in Fig. 26.

#### 5.3.1.4.3 PDCP sub-layer

PDCP provides transmission and reception of Network PDUs in acknowledged, unacknowledged and transparent RLC mode.

It is responsible for the mapping of Network PDUs from one network protocol to one RLC entity and it provides compression in the transmitting entity and decompression in the receiving entity of redundant Network PDU control information (header compression/ decompression).

#### 5.3.1.4.4 BMC sub-layer

The BMC provides a broadcast/multicast transmission service in the user plane on the radio interface for common user data in transparent or unacknowledged mode.

It can handle functionalities such as storage, scheduling and transmission of BMC messages.

#### 5.3.1.5 Layer 3 (radio resource control sub-layer)

The radio resource control (RRC) sub-layer handles the control plane signalling of Layer 3 between the UEs and the radio access network. In addition to the relation with the upper layers (such as core network) the following main functions are performed:

- *Broadcast of information provided by the non-access stratum (core network)* – The RRC layer performs system information broadcasting from the network to all UEs. The system information is normally repeated on a regular basis. This function supports broadcast of higher layer (above RRC) information. This information may be cell specific or not. As an example RRC may broadcast core network location service area information related to some specific cells.
- *Broadcast of information related to the access stratum* – The RRC layer performs system information broadcasting from the network to all UEs. This function supports broadcast of typically cell-specific information.
- *Establishment, maintenance and release of an RRC connection between the UE and this radio interface* – The establishment of an RRC connection is initiated by a request from higher layers at the UE side to establish the first signalling connection for the UE. The

establishment of an RRC connection includes an optional cell re-selection, an admission control, and a Layer 2 signalling link establishment.

- *Establishment, reconfiguration and release of radio access bearers* – The RRC layer will, on request from higher layers, perform the establishment, reconfiguration and release of radio access bearers in the user plane. A number of radio access bearers can be established to an UE at the same time. At establishment and reconfiguration, the RRC layer performs admission control and selects parameters describing the radio access bearer processing in Layer 2 and Layer 1, based on information from higher layers.
- *Assignment, reconfiguration and release of radio resources for the RRC connection* – The RRC layer handles the assignment of radio resources (e.g. codes and, for TDD only, time slots) needed for the RRC connection including needs from both the control and user plane. The RRC layer may reconfigure radio resources during an established RRC connection. This function includes coordination of the radio resource allocation between multiple radio bearers related to the same RRC connection. RRC controls the radio resources in the uplink and downlink such that UE and the radio access network can communicate using unbalanced radio resources (asymmetric uplink and downlink). RRC signals to the UE to indicate resource allocations for purposes of handover to GSM or other radio systems.
- *RRC connection mobility functions* – The RRC layer performs evaluation, decision and execution related to RRC connection mobility during an established RRC connection, such as handover, preparation of handover to GSM or other systems, cell re-selection and cell/paging area update procedures, based on e.g. measurements done by the UE.
- *Paging/notification* – The RRC layer can broadcast paging information from the network to selected UEs. The RRC layer can also initiate paging during an established RRC connection.
- *Control of requested QoS* – This function ensures that the QoS requested for the radio access bearers can be met. This includes the allocation of a sufficient number of radio resources.
- *UE measurement reporting and control of the reporting* – The measurements performed by the UE are controlled by the RRC layer, in terms of what to measure, when to measure and how to report, including both this radio interface and other systems. The RRC layer also performs the reporting of the measurements from the UE to the network.
- *Outer loop power control* – The RRC layer controls setting of the target of the closed-loop power control.
- *Control of ciphering* – The RRC layer provides procedures for setting of ciphering (on/off) between the UE and the radio access network.
- *Initial cell selection and re-selection in idle mode* – Selection of the most suitable cell based on idle mode measurements and cell selection criteria.
- *Arbitration of the radio resource allocation between the cells* – This function shall ensure optimal performance of the overall radio access network capacity.
- *Slow DCA* – Allocation of preferred radio resources based on long-term decision criteria.
- *Timing advance control* – The RRC controls the operation of timing advance.

### 5.3.1.6 Summary of major technical parameters

Parameter	Value	Reference to § 5.3.2
Multiple access technique and duplexing scheme	Multiple access: TDMA/CDMA Duplexing: TDD	5.3.2.1.1
Chip rate (Mchip/s)	3.84 Mcps TDD option: 3.84 1.28 Mcps TDD option: 1.28	5.3.2.1.4
Frame length and structure	3.84 Mcps TDD option: Frame length: 10 ms 15 slots per frame, each 666.666 µs 1.28 Mcps TDD option: Frame length: 10 ms Sub-frame length: 5 ms 7 main slots per sub-frame, each 675 µs TTI: 10 ms, 20 ms, 40 ms, 80 ms, 5 ms (HS-DSCH and PRACH, 1.28 Mcps option only)	5.3.2.1.2
Occupied bandwidth (MHz)	3.84 Mcps TDD option: Less than 5 1.28 Mcps TDD option: Less than 1.6	5.3.2.4.1 5.3.2.4.3
Adjacent channel leakage power ratio (ACLR) (transmitter side)	3.84 Mcps TDD option: UE (UE power class: +21 dBm, +24 dBm) ACLR (5 MHz) = 33 dB ACLR (10 MHz) = 43 dB BS: ACLR (5 MHz) = 45 dB ACLR (10 MHz) = 55 dB 1.28 Mcps TDD option: UE (UE power class: +21 dBm, +24 dBm) ACLR (1.6 MHz) = 33 dB ACLR (3.2 MHz) = 43 dB BS: ACLR (1.6 MHz) = 40 dB ACLR (3.2 MHz) = <del>50</del> 45 dB	5.3.2.4.1 5.3.2.4.3
Adjacent channel selectivity (ACS) (receiver side)	3.84 Mcps TDD option: UE: (UE power class: +21 dBm, +24 dBm) ACS (5 MHz) = 33 dB BS: ACS (5 MHz) = 45 dB 1.28 Mcps TDD option: UE: (UE power class: +21 dBm, +24 dBm) ACS (1.6 MHz) = 33 dB BS: ACS (1.6 MHz) = 45 dB	5.3.2.4.1 5.3.2.4.3
Random access mechanism	3.84 Mcps TDD option: RACH burst on dedicated uplink slot(s) 1.28 Mcps TDD option: Two step random-access with fast physical layer signalling	5.3.2.1.2, 5.3.2.1.5
Channel estimation	Midambles are used for channel estimation	5.3.2.1.2
Inter-base station asynchronous/synchronous operation	Synchronous operation	5.3.2.1.5 5.3.2.4.3