

**3rd Generation Partnership Project (3GPP);
Technical Specification Group (TSG) RAN 3;**

Handovers for real-time services from PS domain

UMTS TR25.936



Reference

<Workitem> (<Shortfilename>.PDF)

Keywords

<keyword[, keyword]>

3GPP

Postal address

Office address

Internet

secretariat@3gpp.org
Individual copies of this deliverable
can be downloaded from
<http://www.3gpp.org>

Copyright Notification

No part may be reproduced except as authorized by written permission.
The copyright and the foregoing restriction extend to reproduction in all media.

©
All rights reserved.

Contents

<u>1</u>	<u>SCOPE</u>	5
<u>2</u>	<u>REFERENCES</u>	5
<u>3</u>	<u>DEFINITIONS, SYMBOLS AND ABBREVIATIONS</u>	5
<u>3.1</u>	<u>DEFINITIONS</u>	5
<u>3.2</u>	<u>SYMBOLS</u>	6
<u>3.3</u>	<u>ABBREVIATIONS</u>	6
<u>4</u>	<u>GSM AND UMTS R99 STATUS</u>	7
<u>4.1</u>	<u>GSM SOLUTION</u>	7
<u>4.2</u>	<u>UMTS R99 STATUS</u>	7
<u>5</u>	<u>REQUIREMENTS</u>	7
<u>5.1</u>	<u>GENERAL</u>	7
<u>5.2</u>	<u>PACKET LOSS</u>	7
<u>5.3</u>	<u>ROUND-TRIP DELAY</u>	7
<u>5.4</u>	<u>SPEECH INTERRUPTION</u>	8
<u>5.5</u>	<u>FREQUENCY OF INTERRUPTION</u>	8
<u>5.6</u>	<u>SECURITY</u>	8
<u>5.7</u>	<u>INTER-SYSTEM OPERATION</u>	8
<u>5.8</u>	<u>BACKWARDS COMPATIBILITY</u>	8
<u>5.9</u>	<u>GENERAL APPLICABILITY OF THE SELECTED SOLUTION</u>	8
<u>5.10</u>	<u>ALIGNMENT OF SELECTED SOLUTION WITH TRANSPORT MECHANISMS WITHIN REL4 CN</u>	8
<u>5.11</u>	<u>SUPPORT FOR MULTIPLE SIMULTANEOUS RABS WITH DIFFERENT QOS</u>	8
<u>6</u>	<u>STUDY AREAS</u>	9
<u>6.1</u>	<u>SOLUTION 1: REUSE OF RELEASE 99 PACKET DUPLICATION MECHANISM</u>	9
<u>6.1.1</u>	<u>General</u>	9
<u>6.1.2</u>	<u>The main steps of Relocation for data forwarding</u>	9
<u>6.1.3</u>	<u>Specifications Impact</u>	15
<u>6.1.4</u>	<u>Interaction with other systems</u>	16
<u>6.1.5</u>	<u>Summary: solution 1</u>	16
<u>6.1.6</u>	<u>Open issues</u>	16
<u>6.2</u>	<u>SOLUTION 2: CORE NETWORK BI-CASTING</u>	17
<u>6.2.1</u>	<u>General</u>	17
<u>6.2.2</u>	<u>Relocation involving 2 SGSNs</u>	17
<u>6.2.3</u>	<u>Relocation involving only one SGSN</u>	22
<u>6.2.4</u>	<u>Specifications Impact</u>	27
<u>6.2.5</u>	<u>Interaction with other systems</u>	28
<u>6.2.6</u>	<u>Summary: solution 2</u>	29
<u>6.2.7</u>	<u>Open issues</u>	30
<u>7</u>	<u>OPEN ITEMS FOR ALL SOLUTIONS</u>	30
<u>8</u>	<u>COMPARISON OF THE SOLUTIONS</u>	30
<u>9</u>	<u>AGREEMENTS</u>	30
<u>10</u>	<u>PROJECT PLAN</u>	30
<u>10.1</u>	<u>SCHEDULE</u>	30
<u>10.2</u>	<u>WORK TASK STATUS</u>	30
<u>11</u>	<u>HISTORY</u>	31

Intellectual Property Rights

Foreword

This Technical Report (TR) has been produced by the 3rd Generation Partnership Project (3GPP), Technical Specification Group RAN.

The contents of this TR are subject to continuing work within 3GPP and may change following formal TSG approval. Should the TSG modify the contents of this TR, it will be re-released with an identifying change of release date and an increase in version number as follows:

Version m.t.e

where:

- m indicates [major version number]
- x the second digit is incremented for all changes of substance, i.e. technical enhancements, corrections, updates, etc.
- y the third digit is incremented when editorial only changes have been incorporated into the specification.

1 Scope

The purpose of the present document is to help the relevant 3GPP groups to specify the changes to existing specifications, needed for the introduction of the "Handover for real-time services from PS domain" Building Block for Release 2000.

The purpose of this R00 work task is to define the relocation procedure to be used when real time services are supported in the PS domain.

The intention with this work item is to provide support for services such as voice over IP and multimedia over IP.

This TR focuses on the requirements for the solution. Possible solutions have been further studied and they are also described in this TR for comparison and evaluation against the requirements. In doing this work, RAN3 has identified some areas of study that are not primarily under RAN3's responsibility. These are mentioned here so that work can be coordinated with the other 3GPP groups.

Changes to the signalling protocols in UTRAN and CN interfaces have also been studied at a high level.

This document is a 'living' document, i.e. it is permanently updated and presented to all TSG-RAN meetings.

2 References

The following documents contain provisions which, through reference in this text, constitute provisions of the present document.

- References are either specific (identified by date of publication, edition number, version number, etc.) or non-specific.
- For a specific reference, subsequent revisions do not apply.
- For a non-specific reference, the latest version applies.
- A non-specific reference to an ETS shall also be taken to refer to later versions published as an EN with the same number.

- [1.] UMTS 23.009: "3rd Generation Partnership Project (3GPP) Technical Specification Group Core Network; Handover Procedures".
- [2.] UMTS 23.060: "3rd Generation Partnership Project (3GPP) Technical Specification Services and System Aspects; GPRS; Service Description".
- [3.] Handovers for real-time services from PS domain, Work Item Description, TSG-RAN#7, submitted as RP-000127rev
- [4.] UMTS 25.413: "3rd Generation Partnership Project (3GPP) Technical Specification Radio Access Network; UTRAN Iu interface RANAP signalling".
- [5.] UMTS 21.905: "3rd Generation Partnership Project (3GPP) Technical Specification Services and System Aspects; Vocabulary for 3GPP specifications".

3 Definitions, symbols and abbreviations

3.1 Definitions

For the purposes of the present document, the following terms and definitions apply.

SRNS relocation:

The definition of [5] applies.

Handover:

The definition of [5] applies.

Hard handover:

The definition of [5] applies.

Relocation, or Relocation of SRNS:

The definition of [4] applies.

Bi-casting:

The capability of a node to receive original data, and send this data in its original form over two different paths.

Duplication:

The capability of a node to receive original data, and send this data over one path in its original form, as well as duplicating it and sending it in a different form over a different path. The duplicated data is in a different form than the original data received.

3.2 Symbols

3.3 Abbreviations

For the purposes of the present document, the following abbreviations apply:

DL	Downlink
GGSN	Gateway GPRS Support Node
GTP	GPRS Tunnelling Protocol
N-PDU	Network PDU
PDCP	Packet Data Convergence Protocol
PDU	Protocol Data Unit
RLC	Radio Link Protocol
RNC	Radio Network Controller
RRC	Radio Resource Control
SGSN	Serving GPRS Support Node
UE	User Equipment
UL	Uplink

4 GSM and UMTS R99 status

4.1 GSM solution

Inter-BSC handovers in GSM are described in ref. [1].

The 2G systems have been optimized to minimize the interruption of speech during handovers. In DL the standards allow bi-casting from the MSC. In UL this is achieved by fast radio resynchronization by the UE. Typical values are in the range of 60 to 120 ms in UL.

4.2 UMTS R99 status

Relocation in UMTS R99 for the CS domain is described in ref. [1].

Similarly to the GSM solution, the interruption of speech during relocation has been minimised. In DL the standards allow bi-casting from the MSC. In UL this is achieved by fast radio resynchronisation by the UE.

In UMTS R99, relocation for the PS domain is described in ref. [2].

It only specifies lossless relocation for non real-time services with high reliability.

The basic principle of the release 99 data forwarding is described as follows:

1. At a given point of time before execution of Relocation of SRNS, source RNC stops to transmit DL data to UE,
2. Source RNC starts to forward to the target RNC, via an GTP tunnel between the RNCs, all the GTP-PDUs which were not transmitted to UE and which continue to arrive from source SGSN to source RNC.
3. Source RNC should store all forwarded data also within source RNC, which ensures lossless operation in Relocation of SRNS failure cases.
4. Target RNC stores all GTP data forwarded from source RNC and when Serving RNC operation is started, target RNC starts the DL data transmission from the first forwarded GTP-PDU.

The R99 mechanism was originally designed for non-real-time services. The principle is that the N-PDUs are forwarded from the source RNC buffers to the target RNC. Data buffering is not adapted to real-time services, and means that interruption may exceed the requirement for real-time services.

5 Requirements

5.1 General

- General requirement is to minimise disruption to the user.

5.2 Packet loss

- Frame loss can already occur over the radio. Therefore when relocation occurs, any frame loss happens in addition to the frames lost over the radio. Therefore frame loss should be minimised.

Editor's note: In CS wireless speech, the FER must not be greater than 1% - does this put any requirement on our solution?

- The packet loss should be similar to what is achieved currently in 2G systems, or smaller.

5.3 Round-trip delay

- The round-trip delay should be minimised in real-time conversational services.
- The round-trip delay should be similar to what is achieved currently in 2G systems, or smaller.

- The global delay variation should be minimised.

5.4 Speech interruption

- The speech interruption should be similar to what is achieved currently in 2G systems, or smaller.

5.5 Frequency of interruption

- The number and frequency of interruption perceived by the user should be minimised.

5.6 Security

Editor's Note: This section is intended to list any security requirements for the real-time handover solution.

5.7 Inter-system operation

Editor's Note: This section is intended to list any requirements for the real-time handover solution due to operation with other systems such as GERAN, UTRAN R99, GSM/GPRS. This is subject to information availability for these other systems.

5.8 Backwards compatibility

Editor's Note: This section is intended to list any requirements for the real-time handover solution in order that it be backwards compatible with current solutions used in UMTS R99, and GSM/GPRS.

5.9 General applicability of the selected solution

It is required, that a unique solution will be finally selected supporting

- hard handover ("UE involved")
- SRNS Relocation ("UE not involved")
- inter-system operation (GERAN<->UTRAN) and
- intra-system operation (GERAN, UTRAN).

The solution shall, additionally, take care of an optimum support for intra-SGSN relocation as well as for the inter-SGSN case.

5.10 Alignment of selected solution with transport mechanisms within Rel4 CN

It is required that the selected solution takes into consideration transport mechanisms selected for the Rel4 ps CN. If the Rel4 transport protocols for the ps domain utilises/requires resource reservation or initialisation of transport characteristics (like is done in cs domain), it shall be ensured that these mechanisms / initialisations / set-up are performed prior to the execution of relocation, as subsequent, delayed bearer setup [Note: whatever "bearer setup" will be called in an Rel4 ps domain] would cause an additional recognisable delay on the overall relocation process, which should be avoided.

5.11 Support for multiple simultaneous RABs with different QoS

It shall be capable to relocate/handover multiple RABs belonging to the same UE with the same signaling transaction on the Iu interface. These RABs, including the RAB for call control signaling, may belong to different QoS classes, and some of them may require lossless relocation/handover.

6 Study areas

6.1 Solution 1: Reuse of release 99 Packet Duplication mechanism

6.1.1 General

The idea of Solution 1 is to reuse the release 99 Data forwarding mechanism also for real time services requiring seamless Relocation of SRNS. Seamless Relocation of SRNS means that the interruptions to the data stream flow are minimised and are basically unnoticeable by the users.

The basic principle of SRNC duplication mechanism would be as follows:

1. At a given point of time before execution of Relocation, source RNC starts to duplicate DL GTP-PDUs: one copy is sent to local PDCP/RLC/MAC, and the other copy is forwarded to the target RNC.
2. Source RNC continues processing and sending DL data normally towards the UE.
3. Target RNC discards all forwarded GTP-PDUs arriving to target RNC until Serving RNC operation is started.
4. When target RNC takes over the serving RNC role, it starts to process the arriving DL GTP-PDUs and send DL data to the UE.

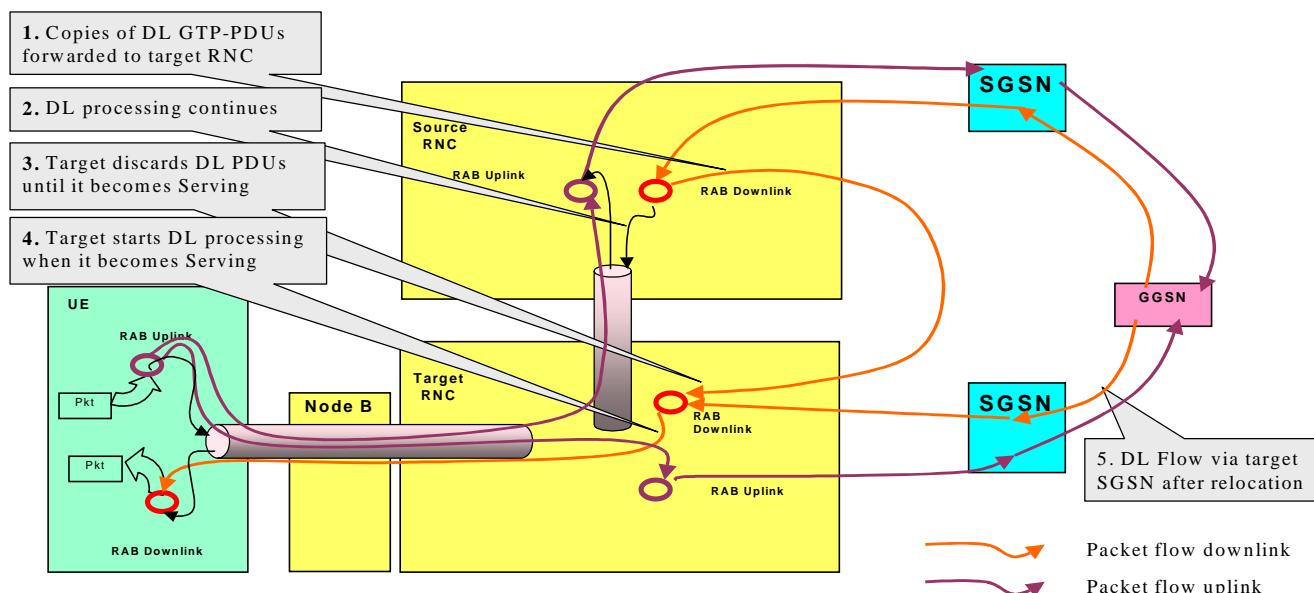

Figure 1: Packet flows during relocation, solution 1

The uplink flow is routed as in R99. The only addition compared to R99 solution is that the source RNC would, during an interim state, duplicate downlink flow to both the UE directly and to the forwarding tunnel.

6.1.2 The main steps of Relocation for data forwarding

[Note: Since for the solution 1 the procedures and mechanisms of performing Relocation of SRNS for all RABs from PS domain are the same, both the handling of lossless and Seamless RABs during Relocation of SRNS are described in this chapter.]

6.1.2.1 Preparation of Relocation of SRNS and Resource allocation

In this phase the UTRAN reserves resources for the relocation.

Specifically for Solution 1, it is assumed that lossless and seamless existing RABs are set to be "subject to data forwarding" in Relocation Command.

At the end of the preparation phase source RNC should:

- for lossless RABs; stop processing DL GTP-PDUs data
- for seamless RABs; continue to process and transmit DL data normally towards UE
- for lossless and seamless RABs; start duplicating all arrived and not acknowledged & arriving DL GTP-PDUs towards target RNC
- for lossless RABs; store all buffered & arriving DL GTP-PDUs

When data forwarding is started, target RNC should:

- for lossless RABs; store all arriving DL GTP-PDUs
- for seamless RABs; discard all arriving DL GTP-PDUs

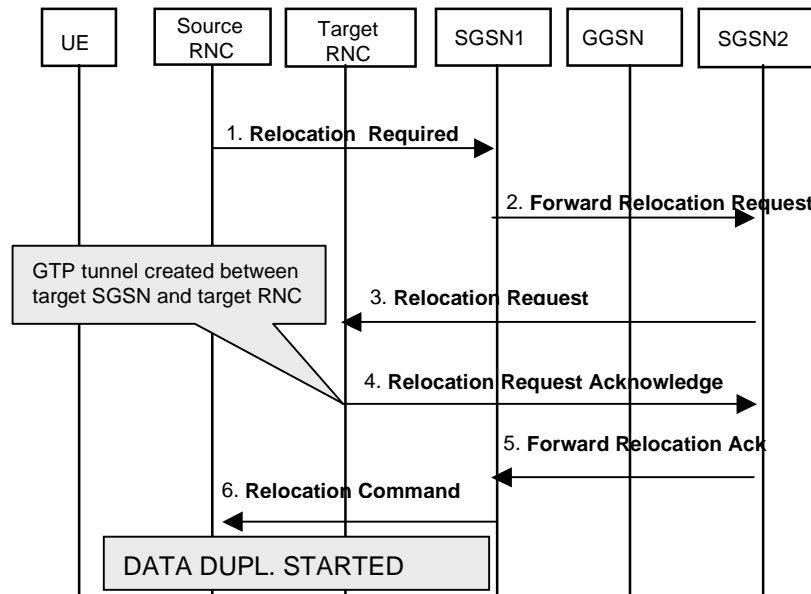

Figure 1 : Control Plane - Preparation of Relocation of SRNS and Resource allocation phase

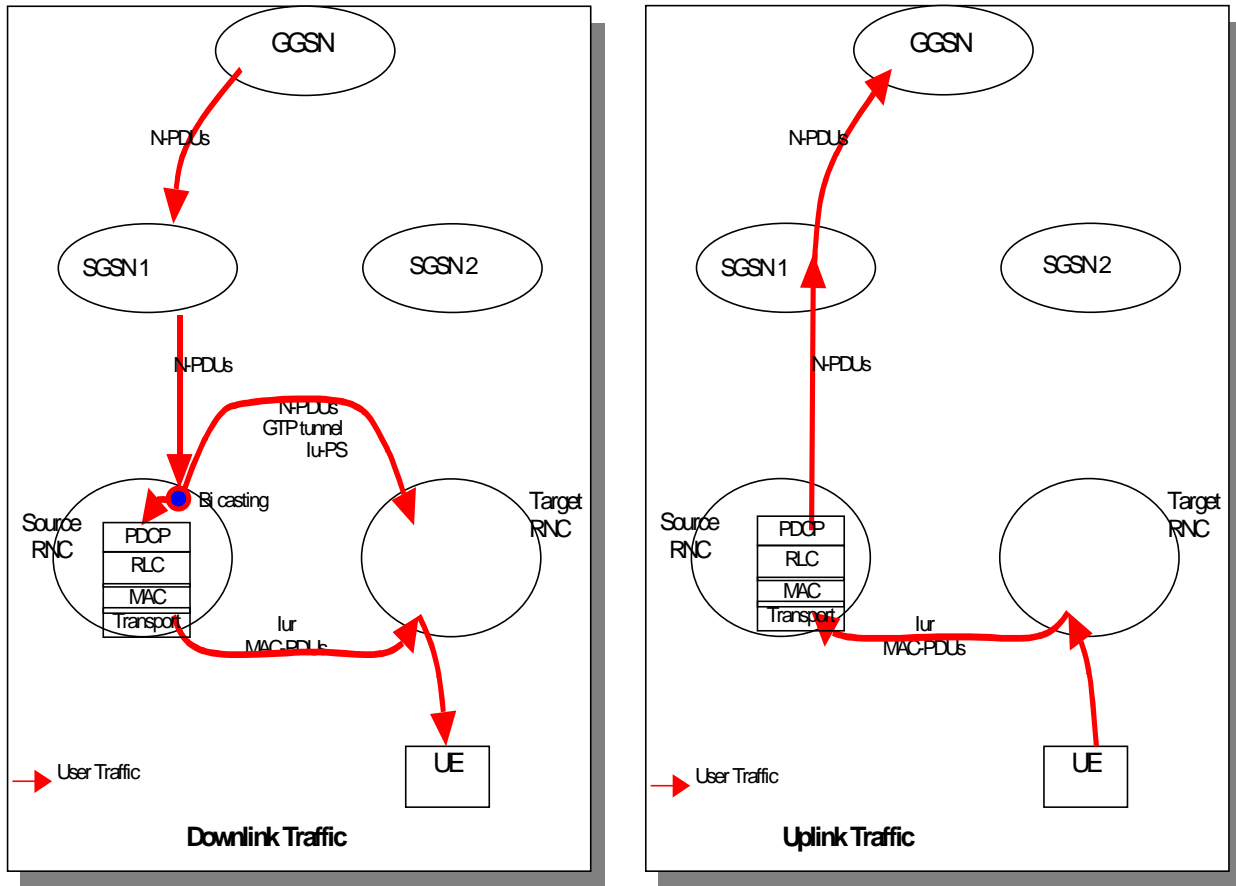

Figure 2 : User Plane - Preparation of Relocation of SRNS and Resource allocation (SRNS Relocation)

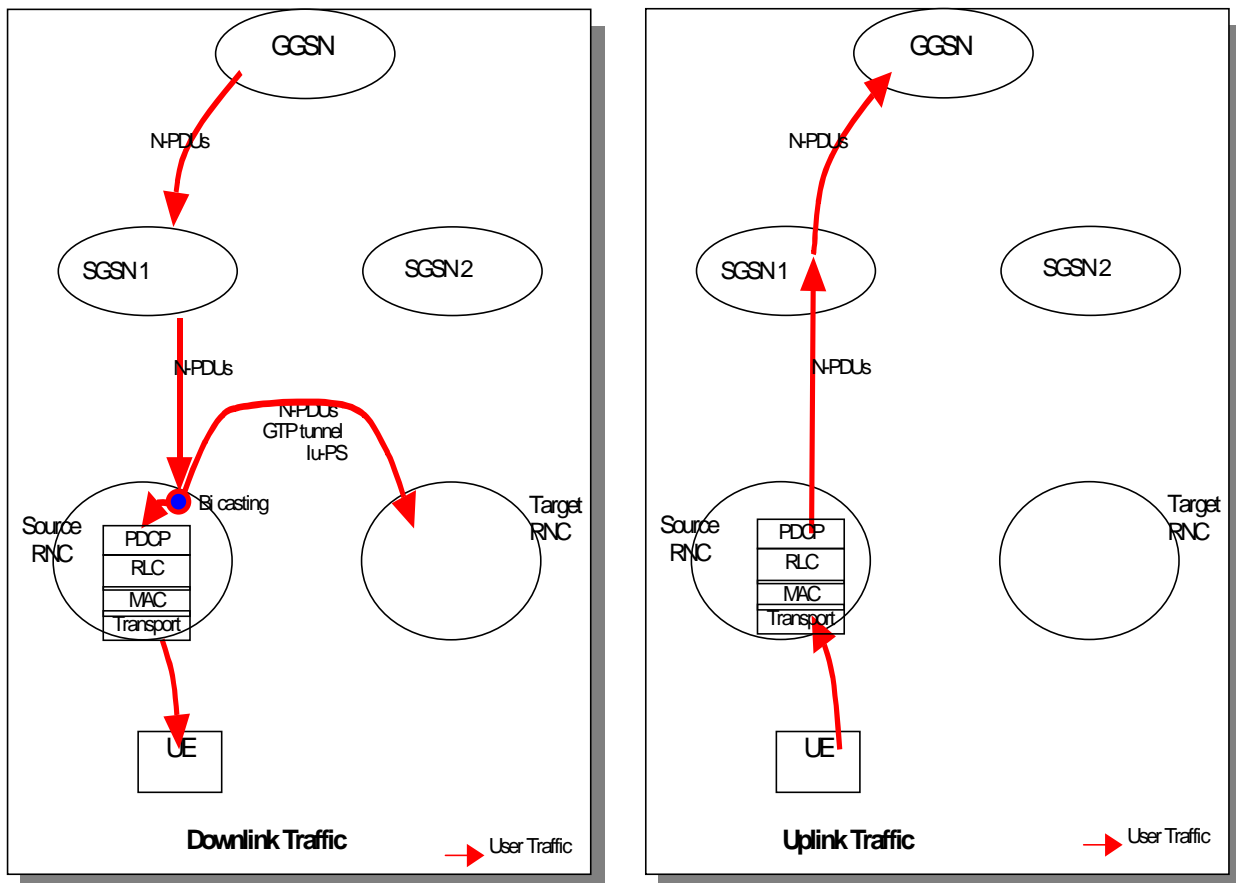

Figure 3 : User Plane - Preparation of Relocation of SRNS and Resource allocation (Hard Handover)

6.1.2.2 Moving the Serving RNC role to target RNC

When source RNC is ready for Relocation of SRNS Execution, it issues the SRNS Relocation Commit or in UE involved case commands the UE to make Hard Handover by appropriate RRC procedure.

For lossless RABs source RNC should forward the Sequence number information to target RNC as defined in Release 99.

After the reception of Relocation Commit from Iur, or in UE involved case when UEs access to target RL is detected by target RNC, target RNC takes over the Serving RNC role.

At this point of time target RNC should:

- for all lossless and seamless RABs; start UL reception of data and start transmission of UL GTP-PDUs towards CN via the new GTP tunnels. The radio interface protocols may need to be reset in order to start radio interface reception.
- for seamless RABs; start processing the arriving DL GTP-PDUs and start DL transmission towards the UE. The radio interface protocols may need to be reset in order to start radio interface transmission.
- for lossless RABs: start processing the buffered and arriving DL GTP-PDUs and start DL transmission towards UE. The radio interface protocols are reset as specified for Release 99 by R2.

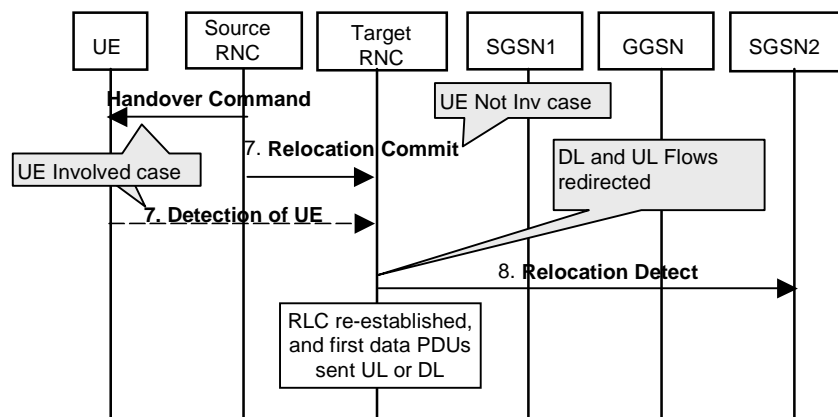

Figure 4 : Control Plane - Moving the Serving RNC role to target RNC

It is FFS how the target SGSN knows the IP address and the TEID of the GGSN.

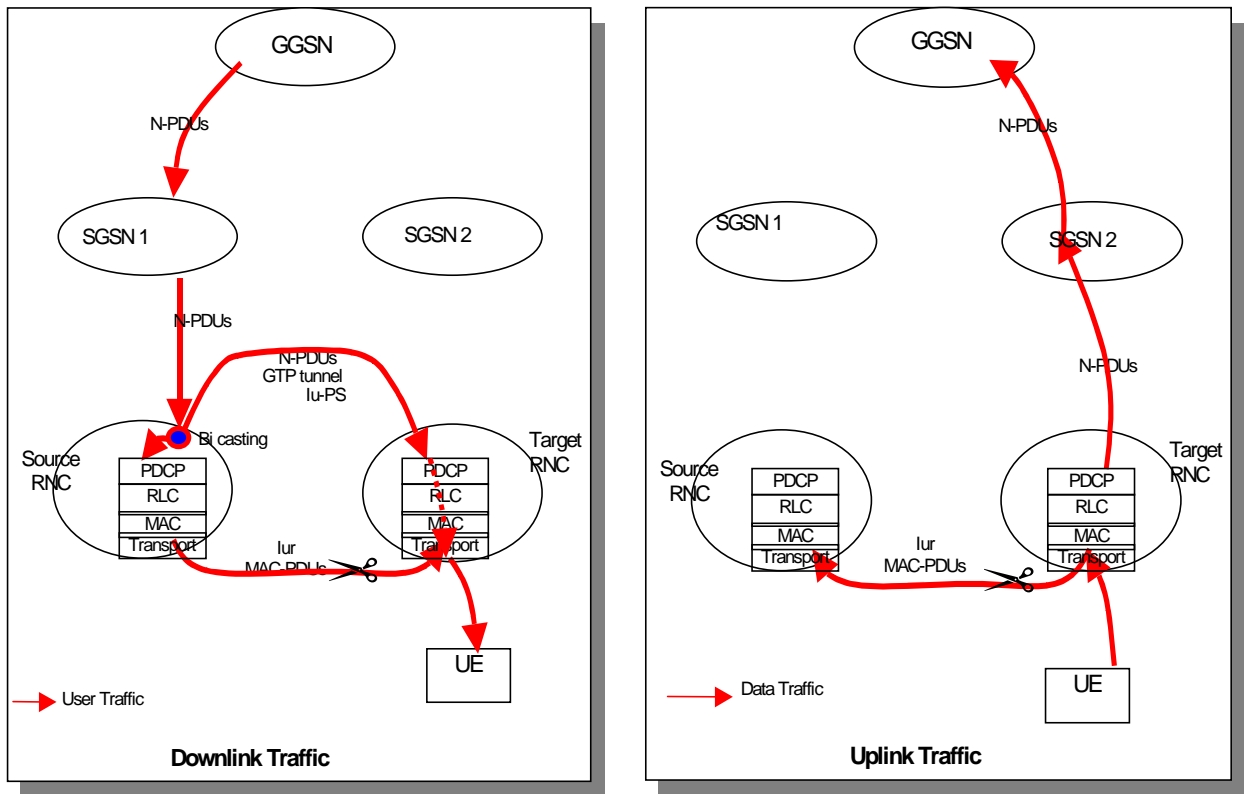

Figure 5 : User Plane - Moving the Serving RNC role to target RNC (SRNS Relocation)

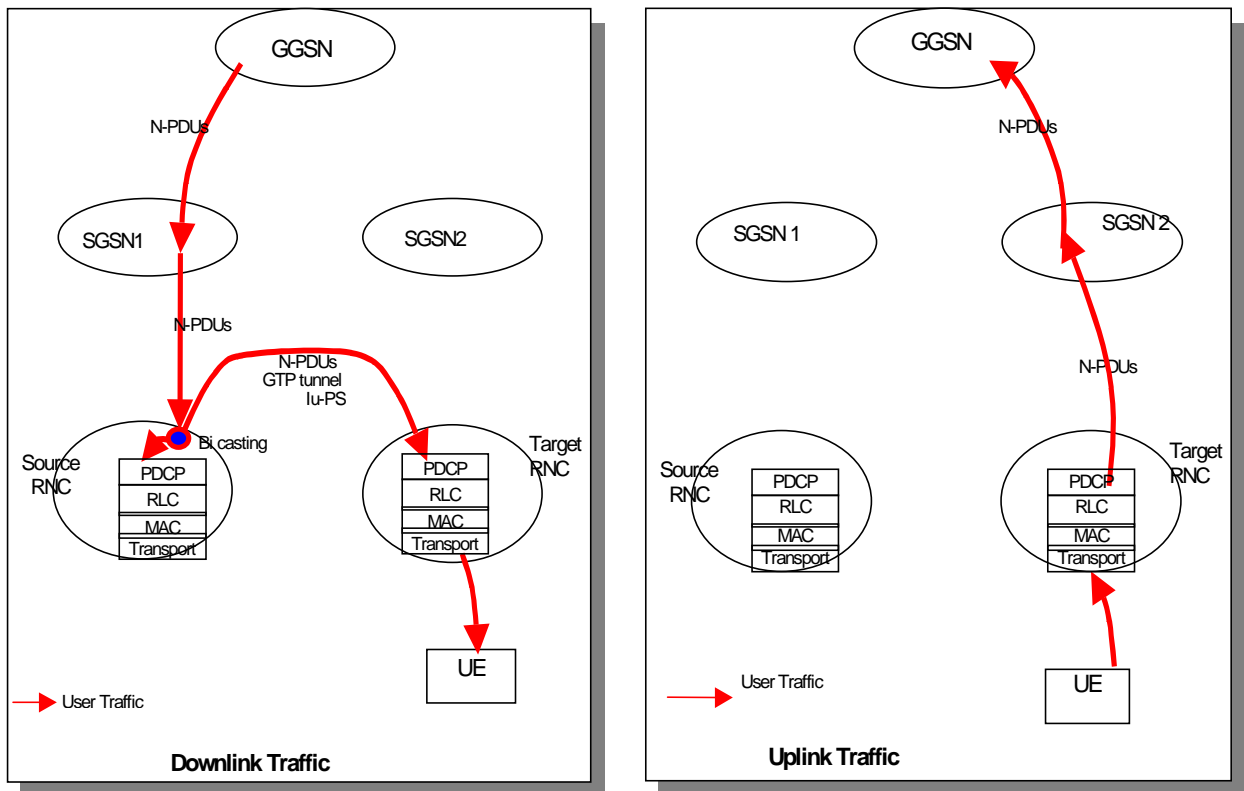

Figure 6 : User Plane - Moving the Serving RNC role to target RNC (Hard Handover)

6.1.2.3 Switching of DL flow in CN

In this phase, the DL GTP tunnel is updated between the SGSN and the GGSN so that the DL flow can use the new route.

The mechanism shown assumes that the DL GTP port used for a given RAB in target RNC is the same for all arriving GTP-PDUs regardless of their arrival route.

Only effect to the UTRAN may be the slightly earlier arrival time of DL-GTP PDUs from SGSN to target RNC. This is handled, as normal arrival time variation, by user plane buffering mechanisms existing in RNC. The additional buffering can be utilised and gradually reduced when the UE moves further from the new serving RNC and the Iur+Iub delays thus increase.

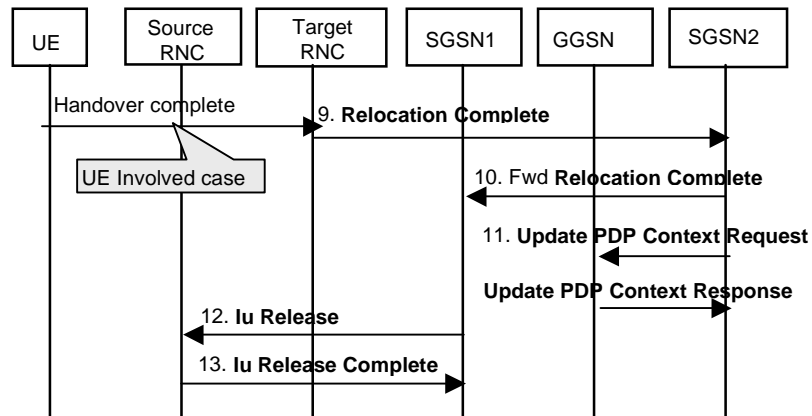

Figure 7 : Control Plane - Switching of DL flow in CN phase

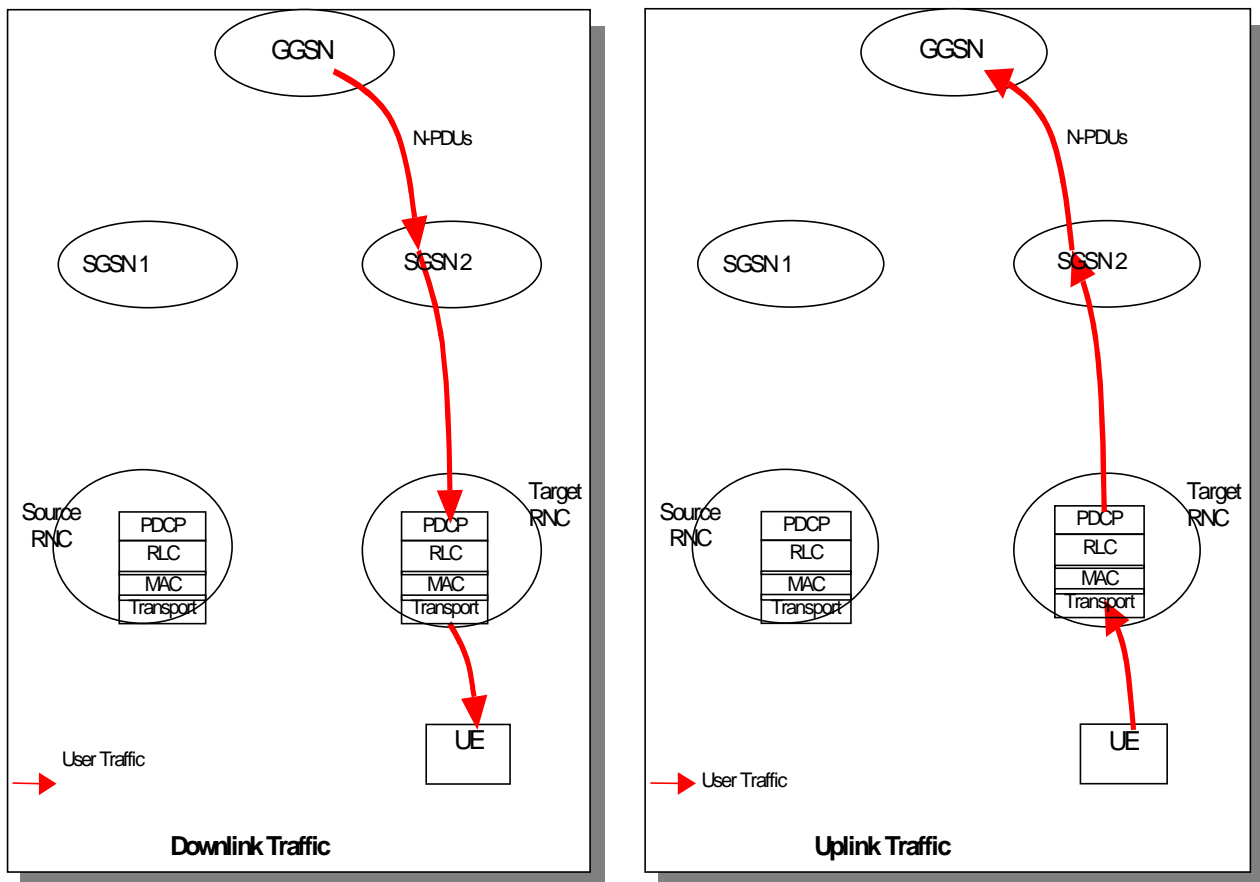

Figure 8 : User Plane - Switching of DL flow in CN

The forwarding tunnel(s) is released with timer supervision as in R99.

It is FFS if the GGSN updating has to wait until after Relocation Complete, or if it can take place earlier.

6.1.3 Specifications Impact

6.1.3.1 Impacts on RAN3 specifications

The Solution 1 reuses the Release 99 data forwarding mechanisms also for the seamless RABs from PS domain. Solution 1 does not require any new procedures, messages nor information elements to be introduced to any RAN 3 specification.

When specifying the release 99 RANAP it was decided by RAN3 to not specify the handling of user plane in application part specifications. This complete independence of user and control plane handling has however introduced some confusion and since the handling of user plane has direct impacts to the Relocation of SRNS characteristics for a given RAB maybe following informative example of user plane handling could be added to the RANAP specification.

X.X.X Example of User Plane handling during Relocation of SRNS

After Relocation Preparation is successfully terminated and before Relocation of SRNS execution is triggered the Source RNC should:

- for lossless RABs; stop processing DL GTP-PDUs data
- for seamless RABs; continue to process and transmit DL data normally towards UE
- for lossless and seamless RABs; start duplicating all arrived and not acknowledged & arriving DL GTP-PDUs towards target RNC
- for lossless RABs; store all buffered & arriving DL GTP-PDUs

After Relocation Resource Allocation procedure is successfully terminated but the serving RNC role is not yet taken over by target RNC and when DL user plane data starts to arrive to target RNC the target RNC should:

- for lossless RABs; store all arriving DL GTP-PDUs
- for seamless RABs: discard all arriving DL GTP-PDUs

When triggering the execution of Relocation of SRNS, source RNC should forward the Sequence number information to target RNC for all lossless RABs as defined in Release 99.

After reception of Relocation Commit from Iur, or in UE involved case when UEs access to target cell is detected by target RNC, target RNC takes over the Serving RNC role.

At this point of time the new Serving RNC should:

- for all lossless and seamless RABs; start UL reception of data and start transmission of UL GTP-PDUs towards CN via the new GTP tunnels. The radio interface protocols may need to be reset in order to start air interface reception.
- for seamless RABs; start processing the arriving DL GTP-PDUs and start DL transmission towards the UE. The radio interface protocols may need to be reset in order to start air interface transmission.
- for lossless RABs: start processing the buffered and arriving DL GTP-PDUs and start DL transmission towards UE. The radio interface protocols are reset as specified for Release 99 by RAN2.

6.1.3.2 Impacts on other groups' specifications

Depending on RAN 2 opinion, maybe addition of one parameter to RRC container could ensure the unambiguous operation of the solution 1. (See the chapter describing the Open Issues).

Stage 2 specification TS 23.060 has to be aligned with the selected solution for RT PS domain Relocation of SRNS.

There might be an impact on 29.060 on the usage of GGSN IP address and TEID.

No other impacts to any 3GPP specification in any other 3GPP groups are seen.

6.1.4 Interaction with other systems

This section is intended to explain how this solution will work with other systems such as GERAN, UTRAN R99, GSM and GPRS. This is subject to information availability for these other systems.

6.1.5 Summary: solution 1

This solution is based on making some procedure enhancements to the R99 mechanisms. During an interim state, the processing of the real time data is done at the source RNC so that the source RNC both sends the traffic to the UE, and forwards it to the target RNC.

This solution also assumes that considering the nature of RT services, there is no need to buffer any DL or UL traffic in the involved nodes.

The Solution 1 reuses the Release 99 data forwarding mechanisms also for the seamless RABs from PS domain. Solution 1 does not require any new procedures, messages nor information elements to be introduced to any RAN 3 specification.

For DL data of seamless RABs solution 1 introduces one instance for possible frame gapping/ overlapping and one additional possible instance for frame gapping/overlapping :

1. The frame overlap/gap may be introduced when target RNC takes the Serving RNC role and starts to produce the DL data from forwarded GTP-PDUs. In this case the estimated gap/overlap is equal to the delay difference between the transport bearer used for Iur DCH data stream and the transport bearer used for data forwarding GTP tunnel both of which are setup between the same source and target RNCs.

If the transport bearer delay difference is smaller than the air interface Transmission Time Interval (TTI) (10, 20, 40 or 80 ms depending on the service) the amount of gap/overlap is most likely non existent.

2. The additional frame gap may be introduced when the CN transport is optimised. In this case the gap will exist only if the delay via the optimised route is larger than the delay via the original route. In the more probable opposite case, the frame overlapping can be avoided by utilising appropriate sequence numbers in GTP headers.

6.1.6 Open issues

How the target SGSN knows the IP address and the TEID of the GGSN?

Does the GGSN updating have to wait until after Relocation Complete, or can it take place earlier?

6.2 Solution 2: Core Network bi-casting

6.2.1 General

The Core Network bi-casting mechanism handles real-time data from the GGSN/SGSN based on the model from GSM and the CS domain in UMTS R99.

The principle is that the packet anchor is at the GGSN/SGSN which acts as the equivalent of the three-party bridge in the CS domain MSC.

During the relocation, real-time downlink N-PDUs are duplicated at the GGSN and sent to the source RNC as well as to the target RNC. Additionally, at the moment the target RNC takes the role of serving RNC, it immediately begins sending uplink N-PDUs towards GGSN via the new SGSN.

The uplink flow is routed as in R99.

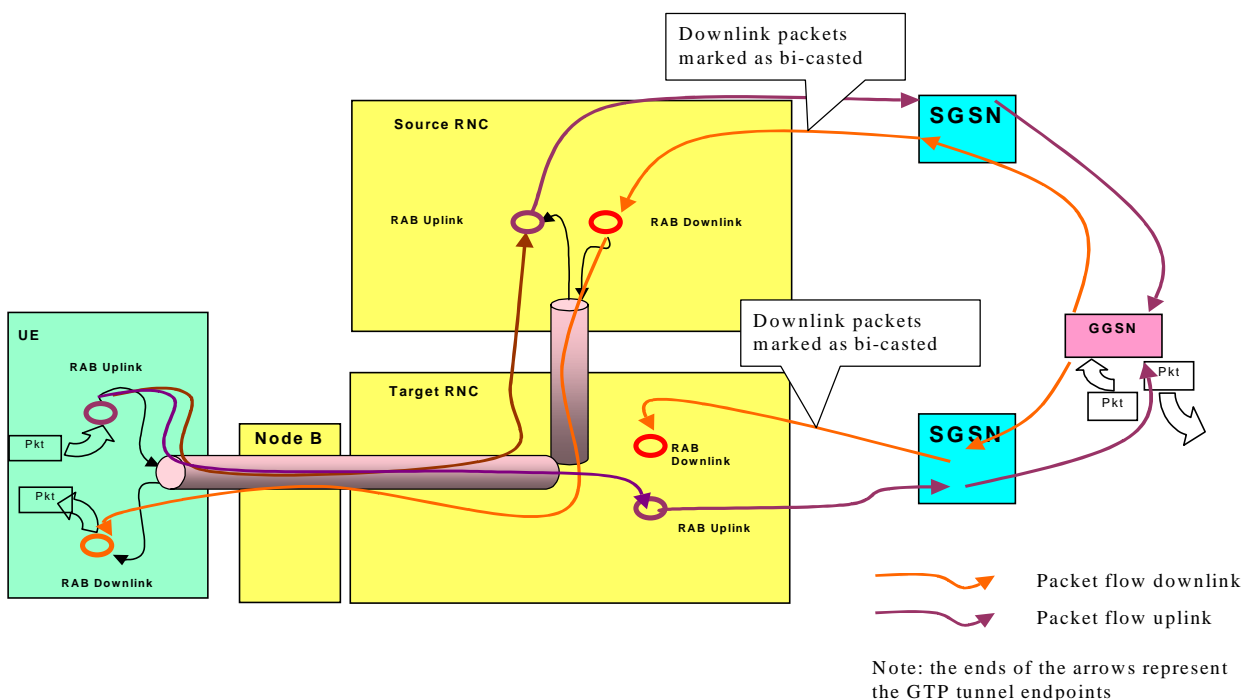

Figure 10: Packet flows during relocation, solution 2

6.2.2 Relocation involving 2 SGSNs

6.2.2.1 Preparation

In this phase the UTRAN reserves resources for the relocation. Then the source SGSN and source RNC are informed when the target RNC is ready. The GGSN is also instructed to start bi-casting downlink N-PDUs as part of the Relocation preparation process. As an implementation choice in the SGSN, this can happen in parallel with the signalling over the Iu interface, as shown in the picture below. This is because there is no need to get any information from the Relocation Request Acknowledge before initiating the Update PDP context.

This means that at the SGSN2, the Update PDP context response and the Relocation Request Ack can be received in any order, but have to be received by SGSN2 so that it can send a Forward Relocation Response to SGSN1.

The Update PDP context request/response is applicable to one PDP context only, therefore one will be done for each RAB. Each request can include the instruction to start bi-casting (seamless RAB), or not (lossless or other RAB).

Should the GGSN reject the bi-casting request, the entire relocation procedure shall be aborted. The original RAB/PDP Context continues unaffected by this abort. Likewise, any PDP Contexts which have begun bi-casting must be updated to revert back to the original configuration. This behaviour is described in more depth in the error handling procedure definition below.

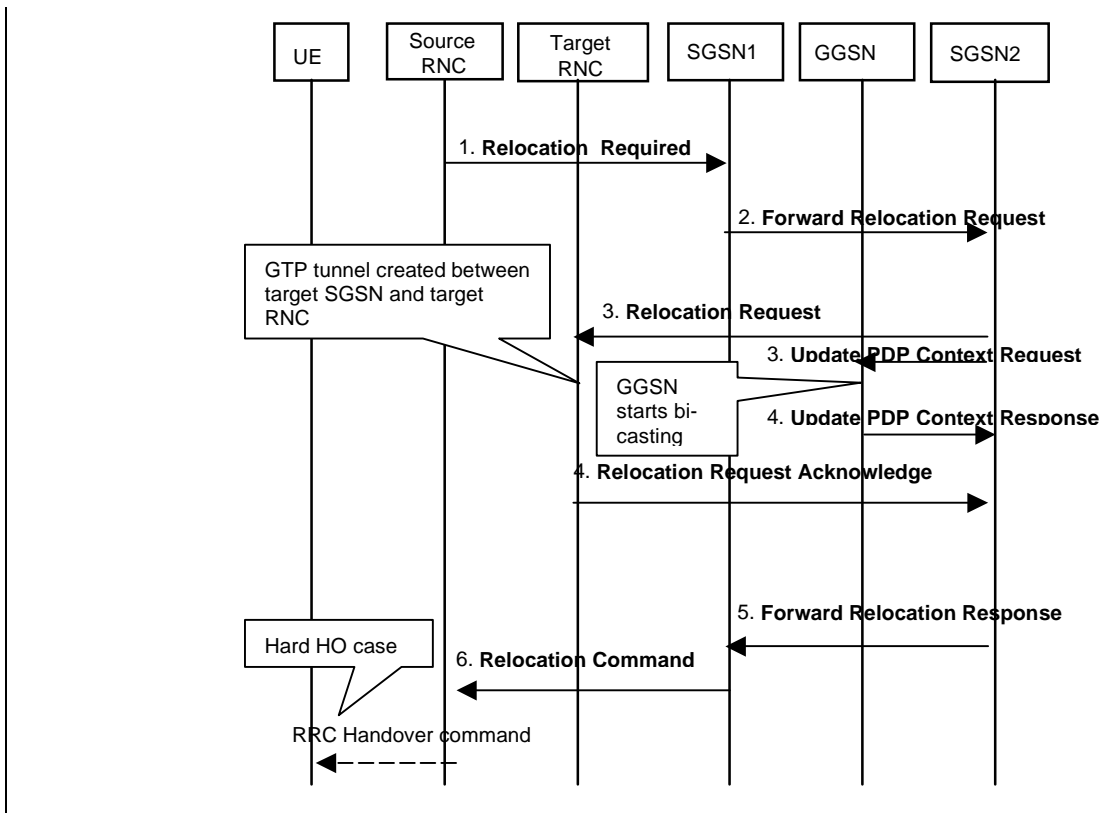

Figure 9 : Control Plane – Preparation involving 2 SGSNs

In the Forward Relocation Response, the RAB setup information is conditional because it is only applicable to lossless RABs. For seamless RABs, this RAB setup information is not included. For lossless RABs, this RAB setup information is included and it instructs SGSN1 of the RNC TEID and RNC IP address for data forwarding from source RNC to target RNC.

Handling of error cases in the Preparation phase:

If the SGSN1 decides to not accept the relocation from the source RNC after reception of message RELOCATION REQUIRED, the SGSN1 shall send a RELOCATION PREPARATION FAILURE message to the source RNC.

If the SGSN2 decides to not accept the relocation, it shall deactivate the PDP context and send a Forward Relocation Response to the SGSN1 as a response of the Forward Relocation Request, with a cause value other than 'Request accepted'. The SGSN1 can then send a RELOCATION PREPARATION FAILURE message to the source RNC.

In case the GGSN is not able to accept the request for the bi-casting, the Update PDP context response message shall be sent from the GGSN to the SGSN2 as a response of the Update PDP Context Request, with a new cause value 'Bi-casting not supported', or 'Bi-casting not possible'.

In this case the SGSN2 shall deactivate the PDP context and send a Forward Relocation Response to the SGSN1 as a response of the Forward Relocation Request, with the cause value from the GGSN ('Bi-casting not supported', or 'Bi-casting not possible'). The SGSN1 can then decide to:

1. send a RELOCATION PREPARATION FAILURE message to the source RNC. This cancels the relocation for all RABs
2. In the case that there are other RABs that do not need seamless treatment, the SGSN1 can send a RAB assignment request modifying the (new parameter) in the RAB parameters to be "other"

In case one of the GGSNs involved decide not to accept the request for relocation, the GGSN that can not accept the relocation will trigger the same process. The source RNC, when it receives RELOCATION PREPARATION FAILURE from the CN, shall initiate the Relocation Cancel procedure on the other Iu signalling connection for the UE if the other Iu signalling connection exists and if the Relocation Preparation procedure is still ongoing or the procedure has terminated successfully in that Iu signalling connection.

In case any of the SGSNs or GGSNs involved decide not to accept the relocation, and if the Iu signalling connection has been established or later becomes established, the SGSN2 shall also initiate the Iu Release procedure towards the target RNC with the cause value "Relocation Cancelled".

If the target RNC can not accept the relocation of SRNS or a failure occurs during the Relocation Resource Allocation procedure in the target RNC, the target RNC shall send RELOCATION FAILURE message to the SGSN2. The SGSN2 shall then deactivate the PDP context and send a Forward Relocation Response to the SGSN1 as a response of the Forward Relocation Request, with a cause value other than 'Request accepted'. The SGSN1 shall then send RELOCATION PREPARATION FAILURE message to the source RNC.

If the source RNC decides to cancel the relocation, it shall send RELOCATION CANCEL to SGSN1. The SGSN1 shall then terminate the possibly ongoing Relocation Preparation procedure towards the target RNC by sending Relocation Cancel Request to the SGSN2 which then initiate the Iu Release procedure towards the target RNC with the cause value "Relocation Cancelled".

Also if the GGSN had already been instructed to start bi-casting then the SGSN1 sends an Update PDP context request to the GGSN. This instructs the GGSN to stop bi-casting, and releases the newly created GTP tunnel between target SGSN and GGSN.

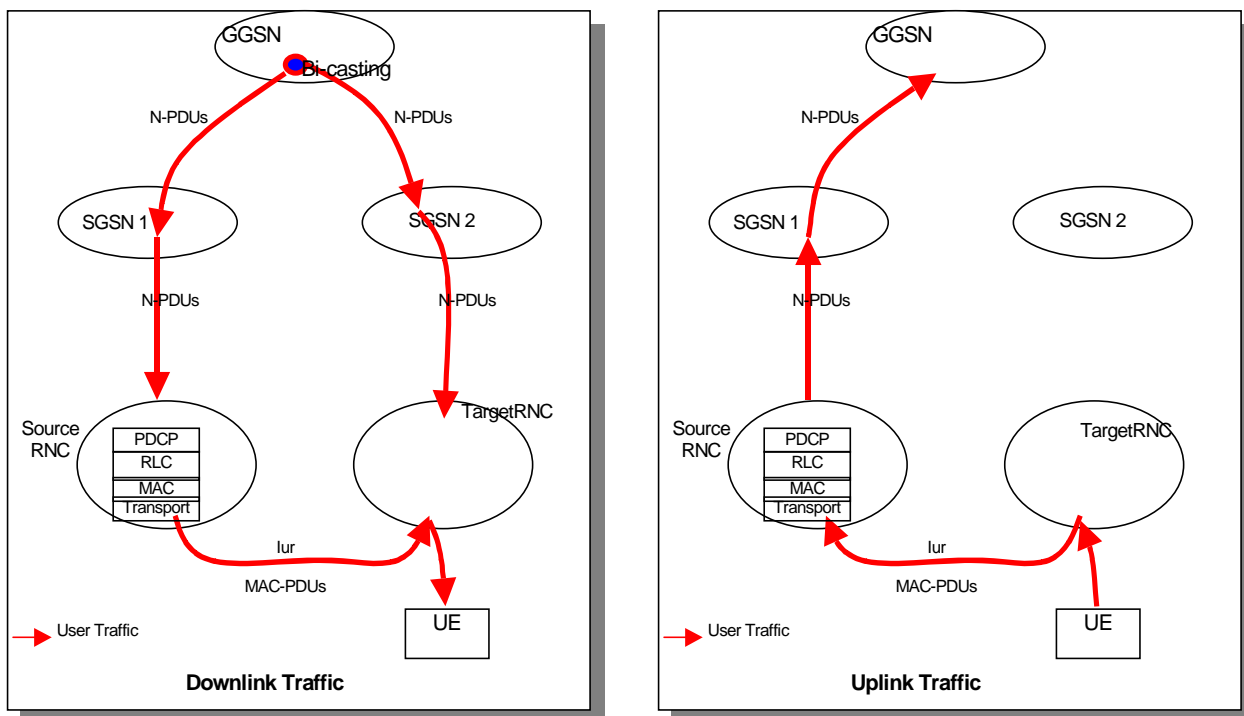

Figure 12: User Plane – Bi-casting of DL flow with 2 SGSNs involved (SRNS Relocation)

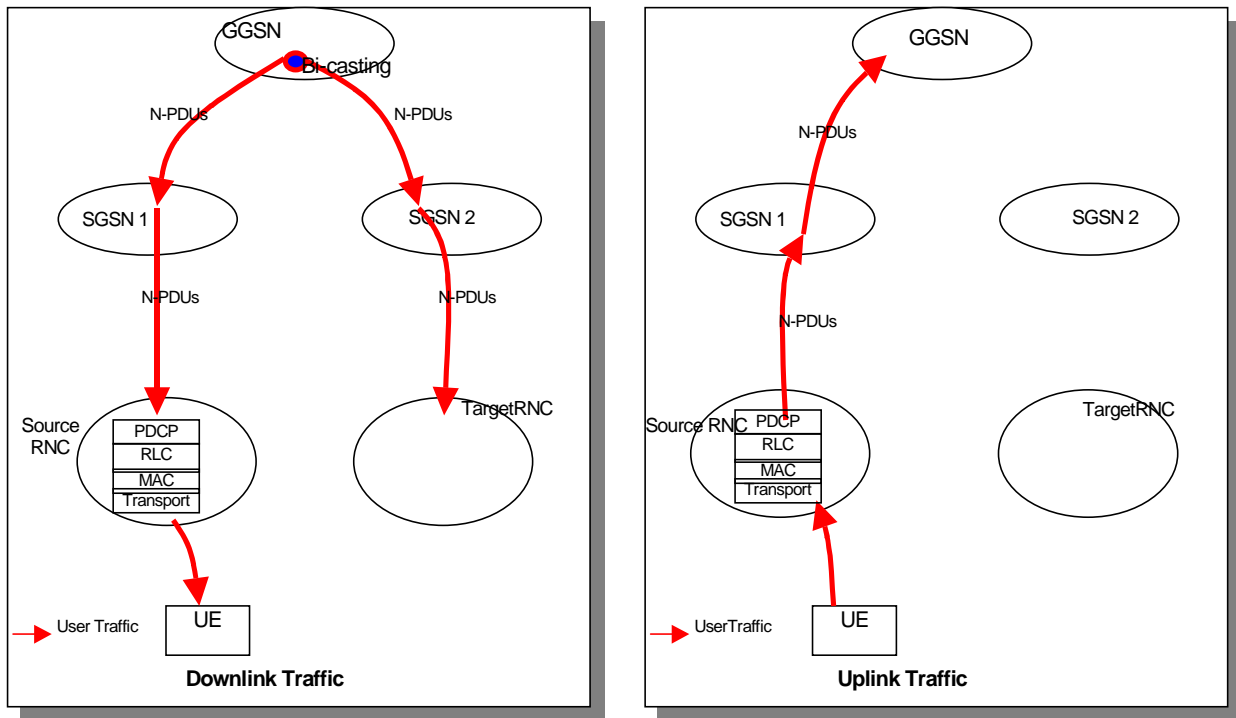

Figure 13: User Plane – Bi-casting of DL flow with 2 SGSNs involved (Hard Handover)

6.2.2.2 Bi-casting of DL flow and switching of UL flow

In this phase, DL traffic is bi-casted from the GGSN to the target RNC (as well as to the source RNC). Also at this point in both the hard handover and SRNS relocation cases, the UE sends UL traffic to the target RNC and UL traffic needs to be switched to the target SGSN and GGSN, using the new route.

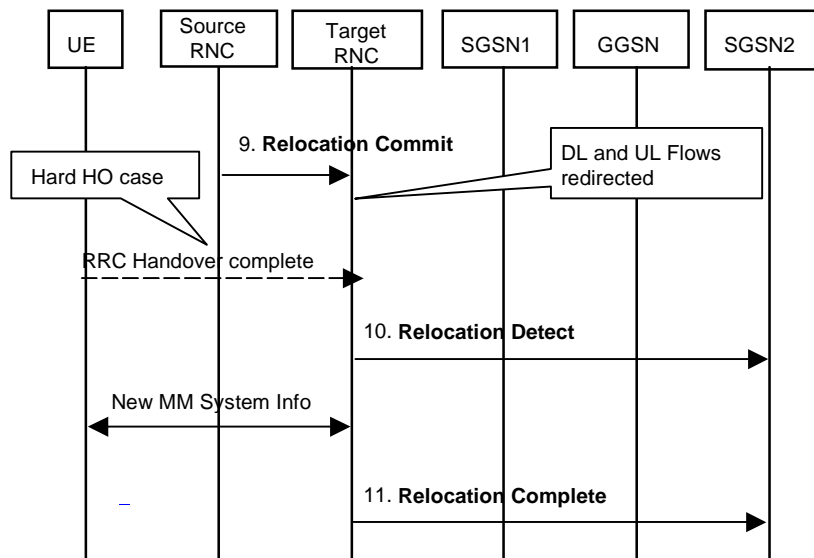

Figure 14 : Control Plane - Bi-casting of DL flow and switching of UL flow phase with 2 SGSNs involved

Handling of abnormal conditions in the Bi-casting phase:

If the RELOCATION DETECT message is not received by the SGSN before reception of RELOCATION COMPLETE message, the SGSN shall handle the RELOCATION COMPLETE message normally.

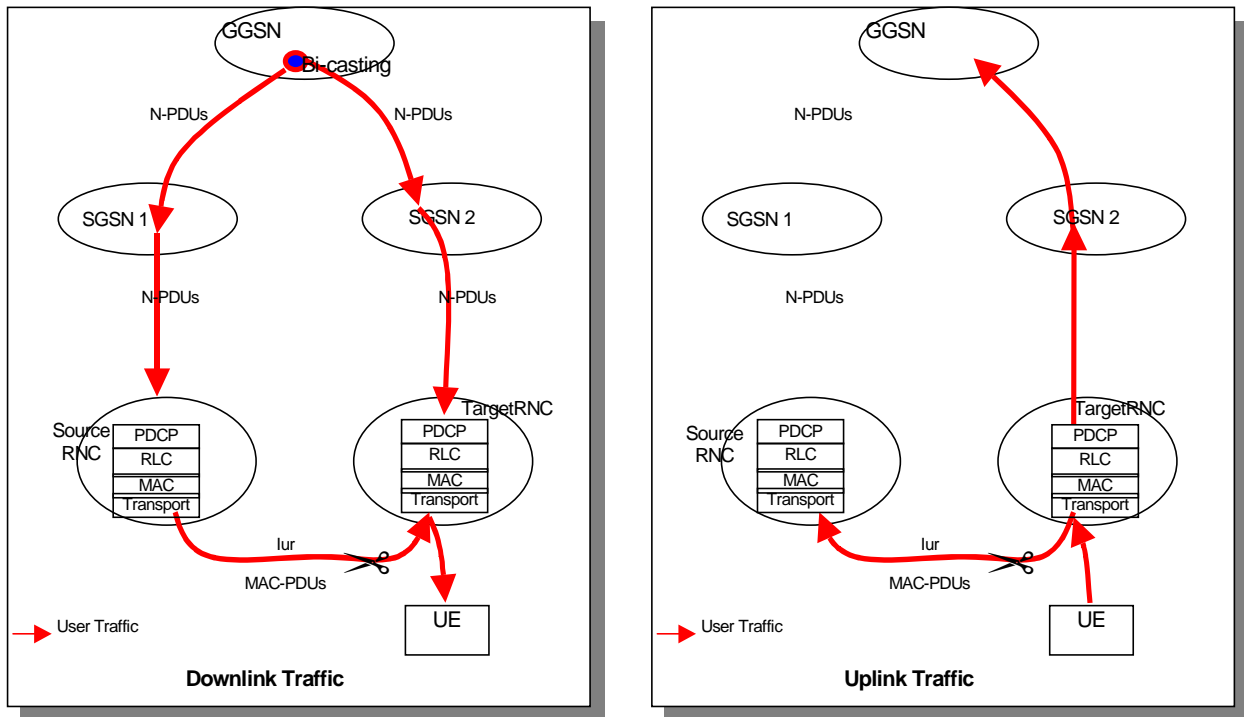

Figure 15: Moving the serving RNC role to target RNC with 2 SGSNs involved (SRNS Relocation)

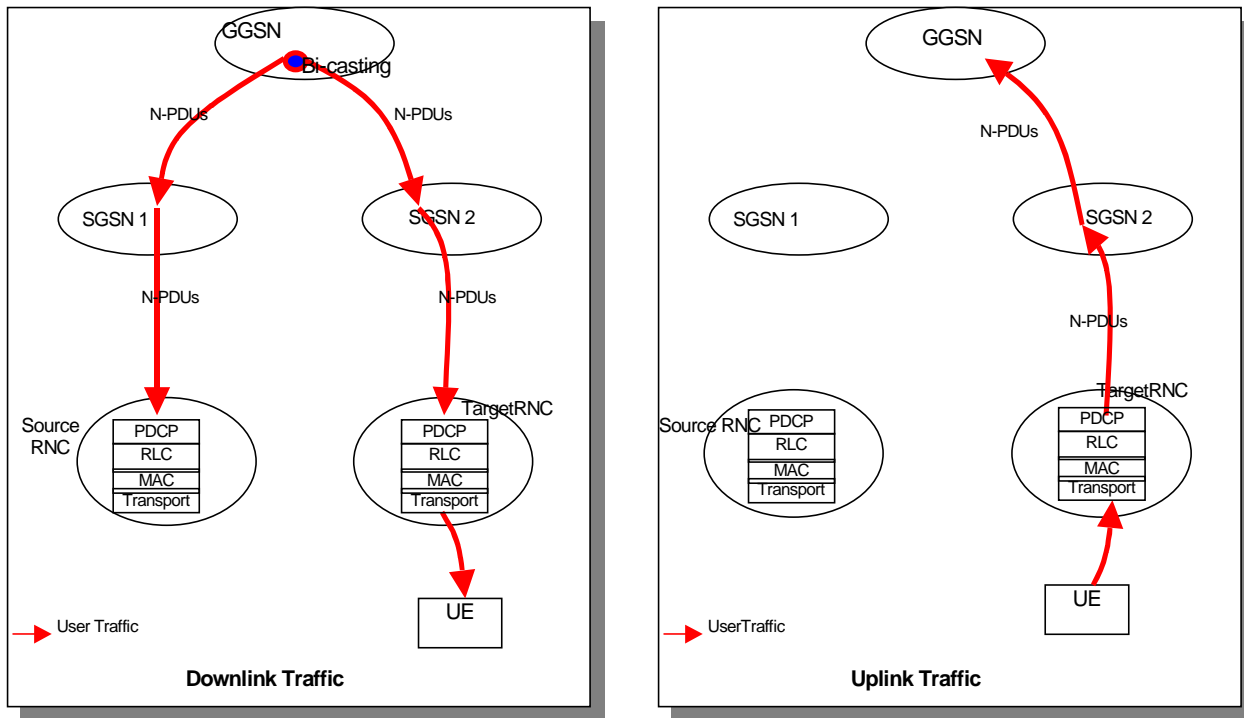

Figure 16 : Moving the serving RNC role to target RNC with 2 SGSNs involved (Hard Handover)

6.2.2.3 Completion

This is the completion of the signalling. Also, the GGSN is instructed to stop bi-casting downlink N-PDUs. At this stage, the relocation has effectively already been completed. Note that SGSN2 informs SGSN1 that the relocation is complete once all of the GGSNs involved have stopped the bi-casting. Then it informs SGSN1 to release the Iu connection towards the Source RNC.

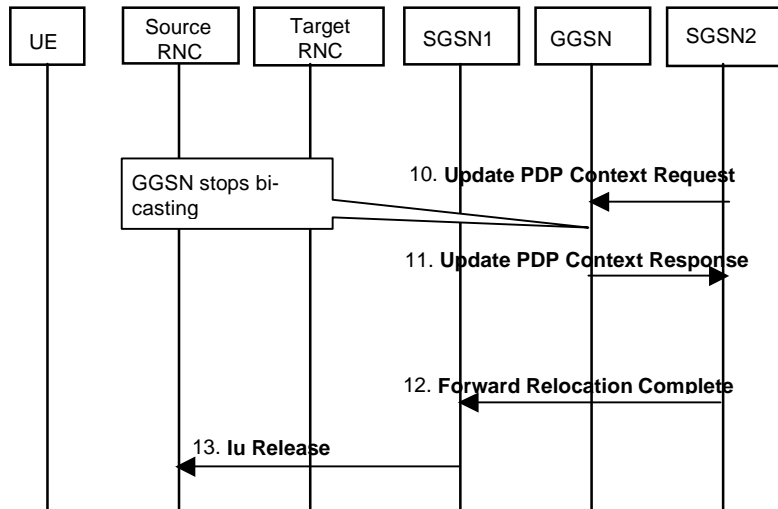

Figure 17: Control Plane – Completion with 2 SGSNs involved

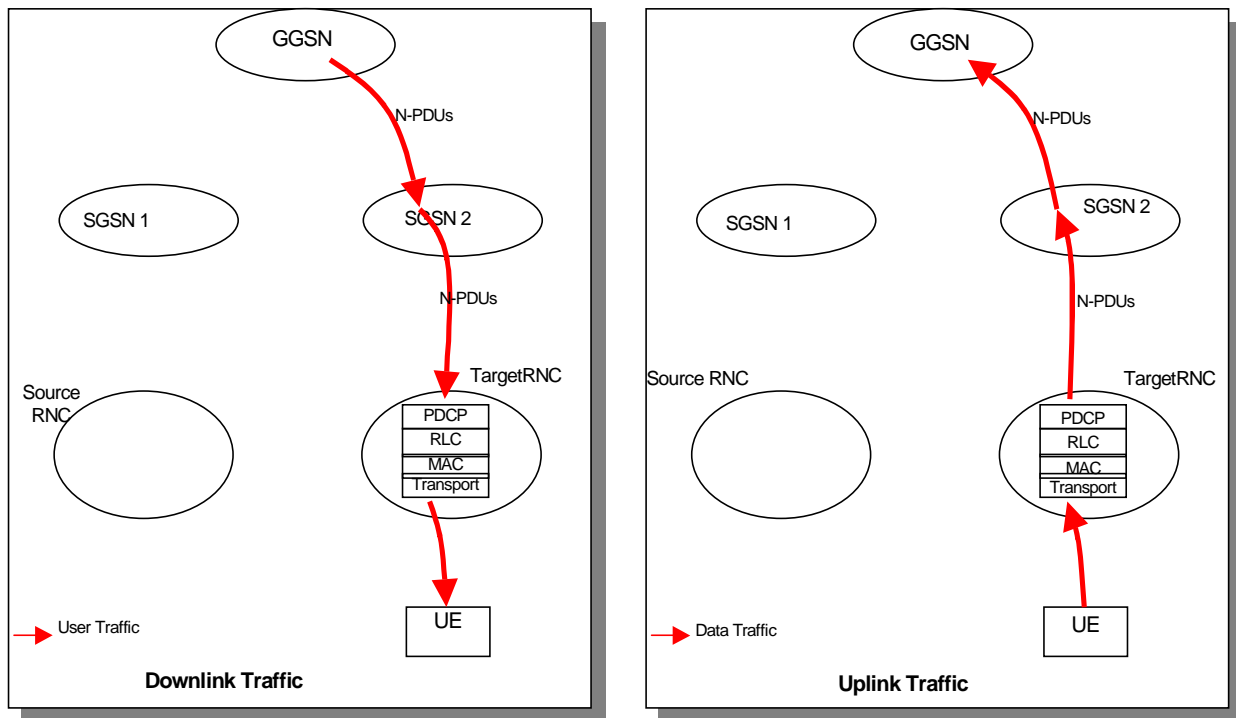

Figure 18: User Plane – Completion with 2 SGSNs involved

6.2.3 Relocation involving only one SGSN

In the case that the relocation involves only one SGSN, the flow of N-PDUs across the Gn interface does not need to be changed. Indeed, the tunnel switching point in the SGSN can serve as the anchor for the tunnel instead of the GGSN as proposed above.

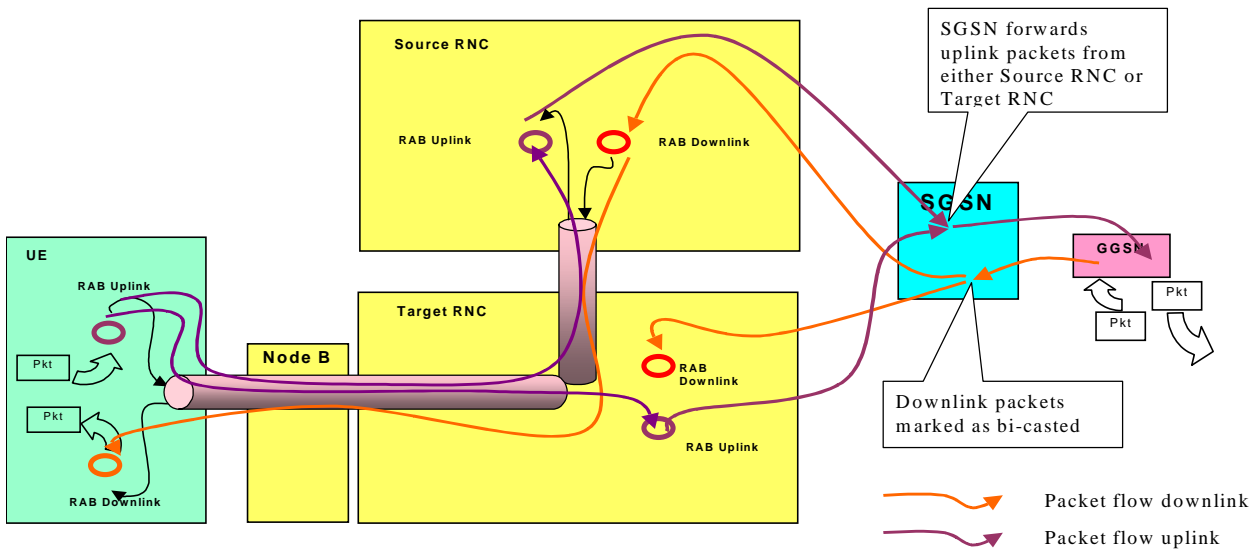

Figure 19: Packet flows during relocation with only one SGSN involved, solution 2

As illustrated in the above figure, the SGSN forwards N-PDUs from either the source RNC or the target RNC allowing the N-PDUs to start flowing from the DRNC as soon as possible after the switchover. The procedure is explained below with the change in operation when the GGSN is not involved.

6.2.3.1 Preparation

In this phase the UTRAN reserves resources for the relocation. Then the source SGSN and source RNC are informed when the target RNC is ready. The SGSN starts bi-casting downlink N-PDUs as part of the Relocation preparation process.

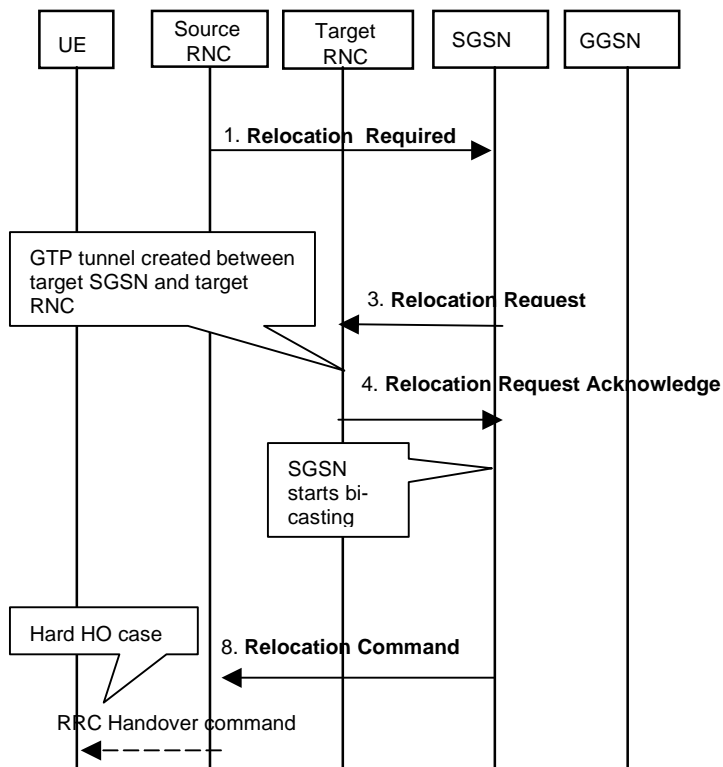

Figure 20: Control Plane – Preparation phase with only one SGSN

Handling of abnormal conditions in the Preparation phase:

If the SGSN decides to not accept the relocation from the source RNC after reception of message RELOCATION REQUIRED, the SGSN shall stop timer $T_{RELOC_{alloc}}$ and send a RELOCATION PREPARATION FAILURE message to the source RNC.

If the Iu signalling connection has been established or later becomes established, the SGSN shall also initiate the Iu Release procedure towards the target RNC with the cause value "Relocation Cancelled".

If the target RNC can not accept the relocation of SRNS or a failure occurs during the Relocation Resource Allocation procedure in the target RNC, the target RNC shall send RELOCATION FAILURE message to the SGSN. The SGSN shall then send RELOCATION PREPARATION FAILURE message to the source RNC.

If the source RNC decides to cancel the relocation, it shall send RELOCATION CANCEL to SGSN. The SGSN shall then terminate the possibly ongoing Relocation Preparation procedure towards the target RNC by initiating the Iu Release procedure towards the target RNC with the cause value "Relocation Cancelled".

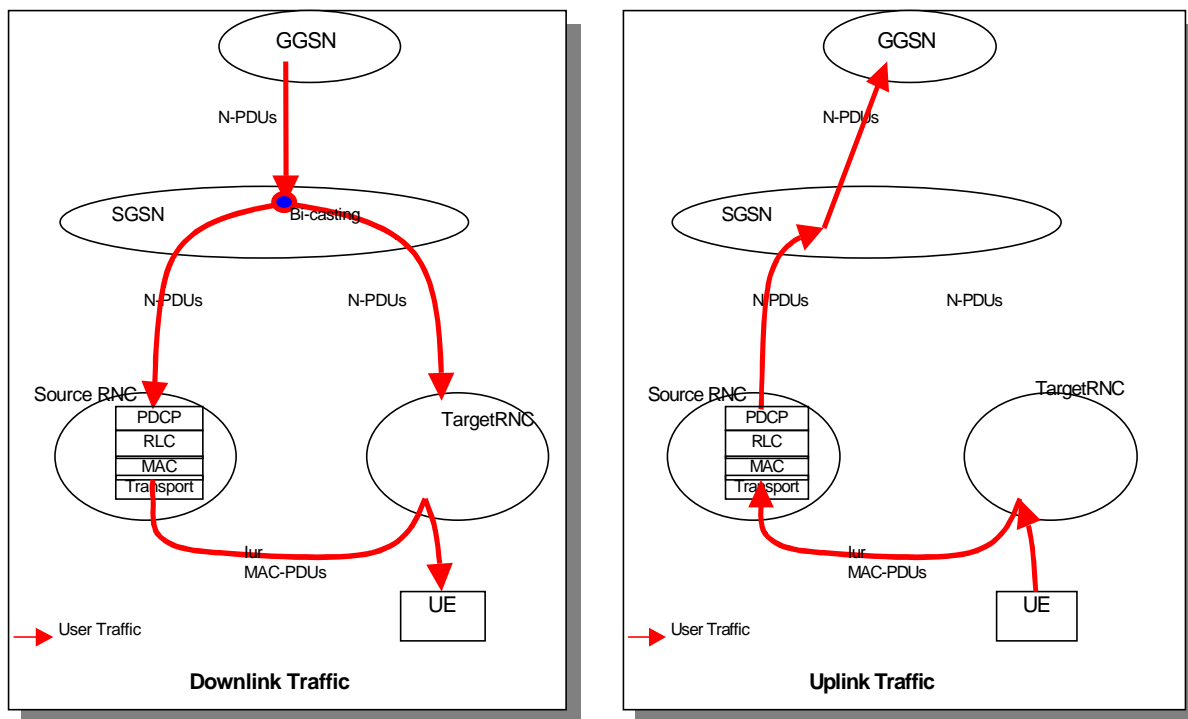

Figure 21: User Plane - Bi-casting of DL flow with only one SGSN (SRNS Relocation)

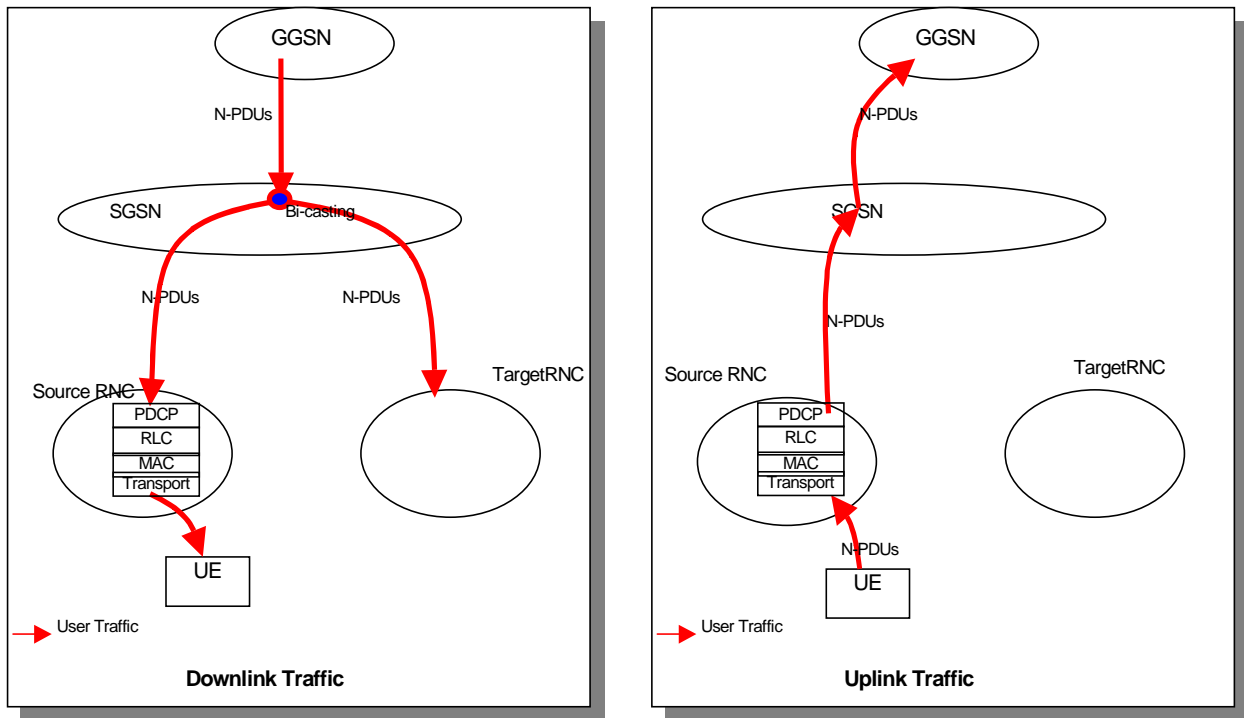

Figure 22: User Plane - Bi-casting of DL flow with only one SGSN (Hard Handover)

6.2.3.2 Bi-casting of DL flow and switching of UL flow

In this phase, DL traffic is bi-casted from the SGSN to the target RNC (as well as to the source RNC). Also at this point in both the hard handover and SRNS relocation cases, the UE sends UL traffic to the target RNC and UL traffic needs to be switched to the SGSN and using the new route.

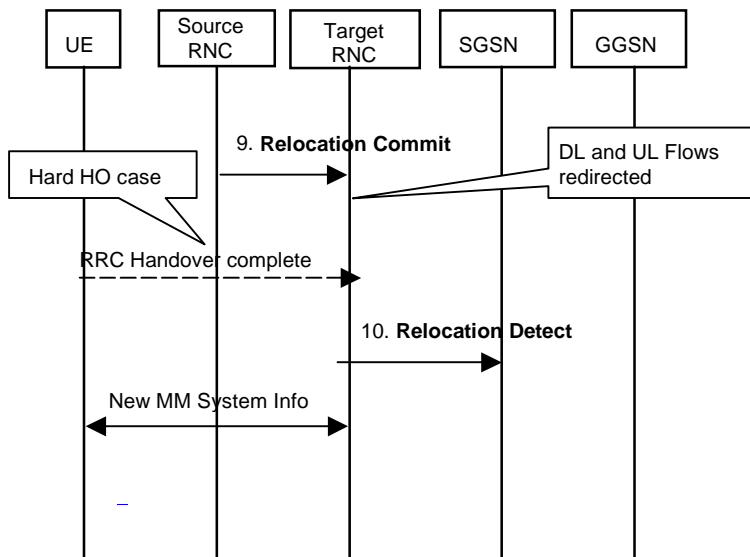

Figure 23: Control Plane - Bi-casting of DL flow and switching of UL flow phase with only one SGSN

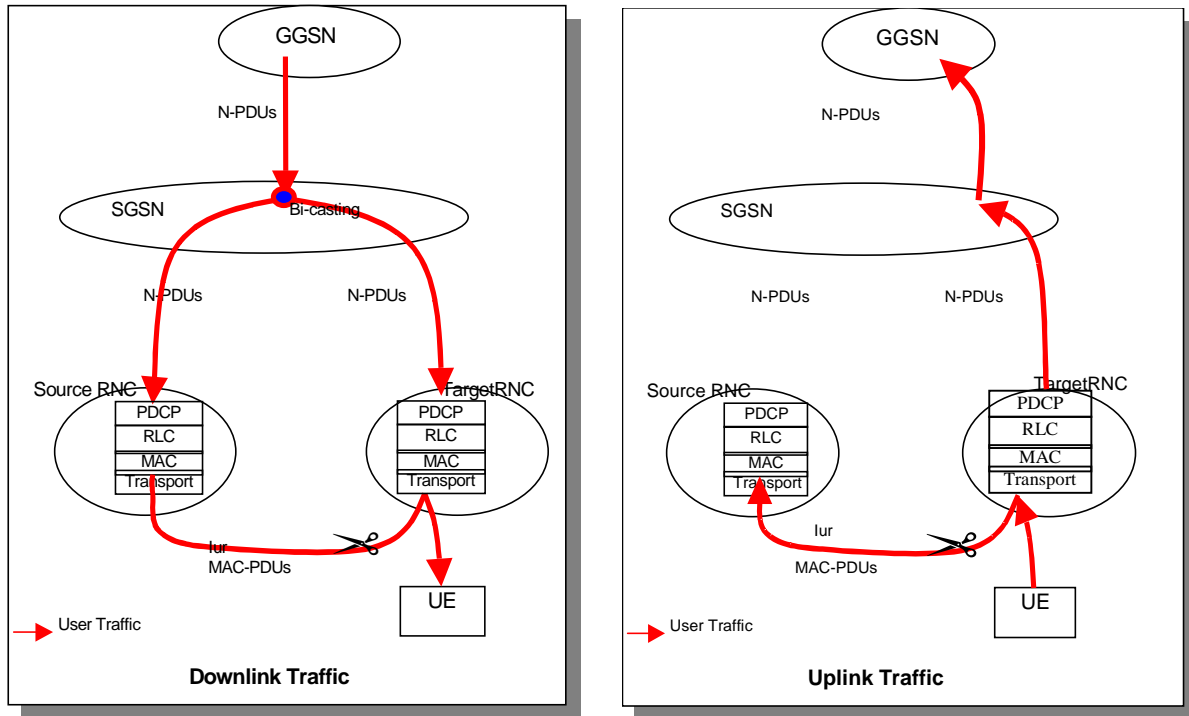

Figure 24: Moving the serving RNC to target RNC with only one SGSN (SRNS Relocation)

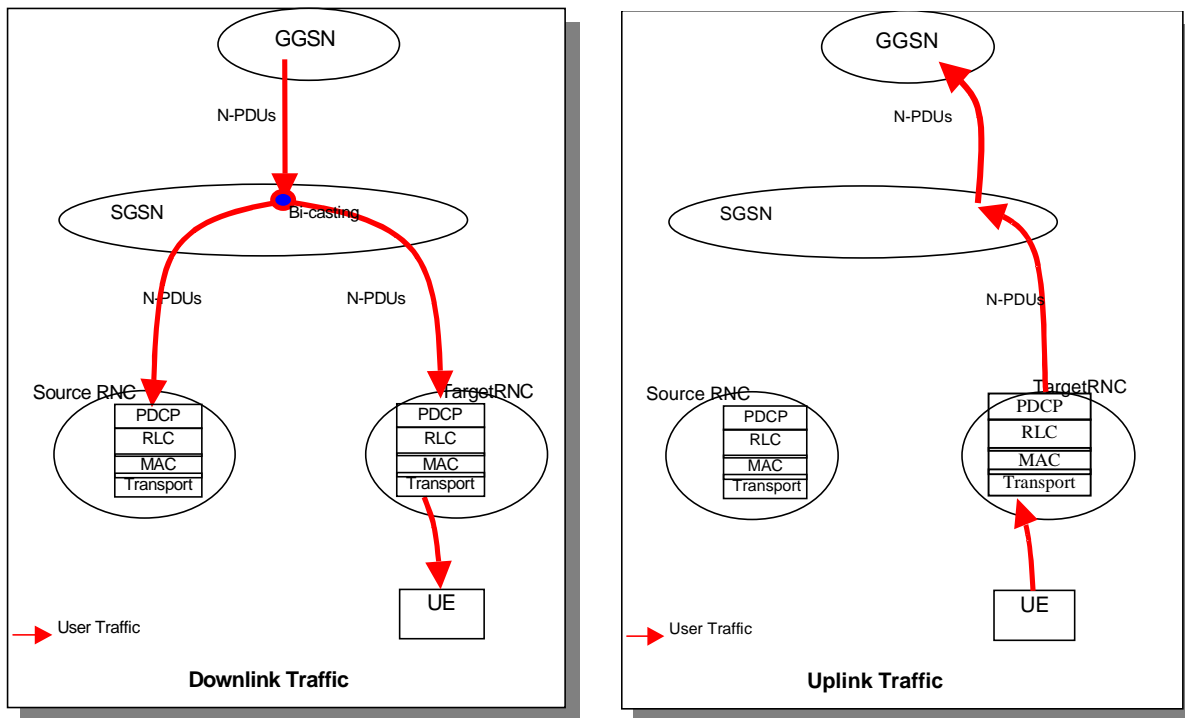

Figure 25: Moving the serving RNC to target RNC with only one SGSN (Hard Handover)

6.2.3.3 Completion

This is the completion of the signalling. Also, the SGSN is instructed to stop bi-casting downlink N-PDUs. At this stage, the relocation has effectively already been completed.

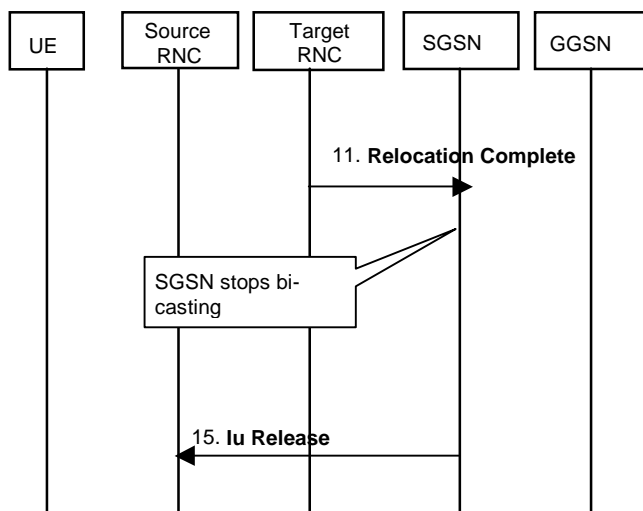

Figure 26: Control Plane – Completion phase with only one SGSN

Handling of abnormal conditions in the Completion phase:

If the RELOCATION DETECT message is not received by the SGSN before reception of RELOCATION COMPLETE message, the SGSN shall handle the RELOCATION COMPLETE message normally.

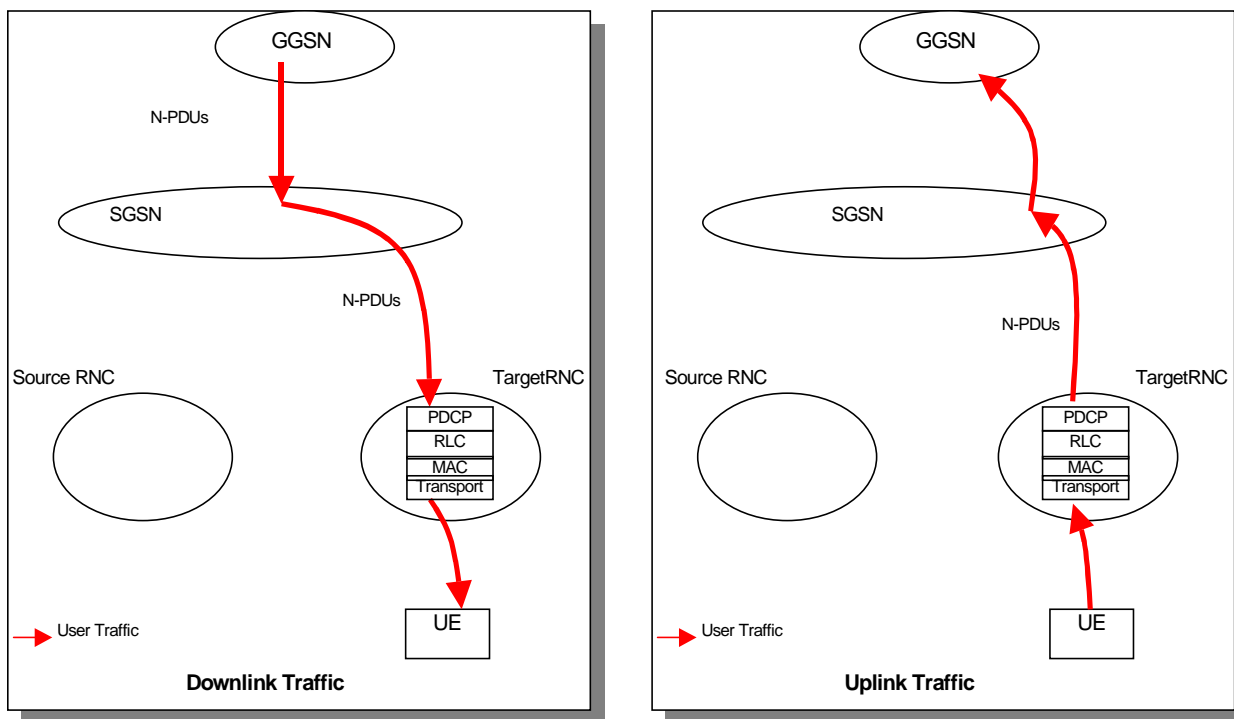

Figure 27: User Plane – Completion phase with only one SGSN

6.2.4 Specifications Impact

6.2.4.1 Impacts on RAN3 specifications

Solution 2 does not require any new procedures or messages to be introduced to any RAN 3 specification. If a clear indication is added to the RAB parameters that a RAB is to be treated in a “lossless” or “other” way, then a new value for that Information Element is needed to indicate “seamless” to the source RNC. This is pending resolution of the R99 issue pointed out in LS R3-002874.

6.2.4.2 Impacts on other groups' specifications

The impacts to other groups' specifications relate to inclusion of bi-casting from GGSN to the Gn interface specification and corresponding stage 2 specifications.

Procedures to initialise and terminate the GGSN bicasting from SGSN including error cases needs to be defined by TSG CN WG4.

29.060 example changes:

The Bi-cast request indicates to the GGSN the requirement for real-time relocation.

Information Elements in an SGSN-Initiated Update PDP Context Request

Information element	Presence requirement	Reference
Recovery	Optional	7.7.11
Tunnel Endpoint Identifier for Data (I)	Mandatory	7.7.13
Tunnel Endpoint Identifier Control Plane	Conditional	7.7.14
NSAPI	Mandatory	7.7.17
Trace Reference	Optional	7.7.24
Trace Type	Optional	7.7.25
SGSN Address for Control Plane	Mandatory	GSN Address 7.7.32
SGSN Address for User Traffic	Mandatory	GSN Address 7.7.32
Quality of Service Profile	Mandatory	7.7.34
TFT	Optional	7.7.36
Trigger Id	Optional	7.7.41
OMC Identity	Optional	7.7.42
Bi-cast request	Conditional	New reference
Private Extension	Optional	7.7.44

Bi-casting Request Information Element

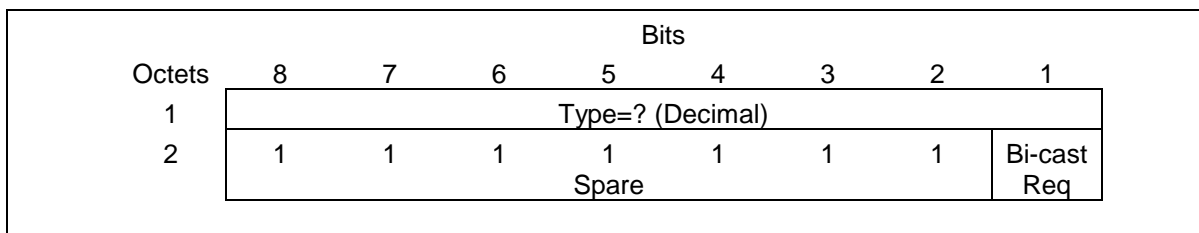

Bi-casting Request Values

Bi-casting request	Value (Decimal)
Stop	0
Start	1

New cause value

response	rej	Bi-casting not supported	New
		Bi-casting not possible	New

When creating a new PDP context, an indication is needed to indicate that the RAB is to be treated in a seamless way.

GTP-U changes to flag packets as bi-casted are needed. The spare bit (bit 4) of octet 1 in the GTP header (defined in Figure 2 of section 6 of 29.060) could be utilized to indicate if a packet was bi-casted.

Stage 2 specification TS 23.060 has to be aligned with the selected solution for RT PS domain Relocation of SRNS.

6.2.5 Interaction with other systems

The Core Network bi-casting solution will work with a GERAN connected via the Iu-PS in exactly the same way as with a UTRAN connected via the Iu-PS. Therefore all the description above is applicable to GERAN, with the RNC being

replaced by a BSS (can contain BSCs or not). There is no other functionality required at the BSS other than supporting the messaging for the Iu-PS (release 4).

If a release 4 Core Network is connected to a GPRS BSS, since there is no Iu-PS, no relocation can be provided.

If a release 4 Core Network is connected to a R99 UTRAN, then for lossless RABs, the Core Network can request data forwarding. For seamless RABs, the Core Network can not request data forwarding, and wont do bi-casting either since R99 UTRAN does not support real-time services.

The SGSN will request handover treatment from the RNC as follows:

	Rel 99 CN	Rel 4 CN
Rel 99 UTRAN	Will only request lossless or other	Will request lossless, other or seamless (which will fail)
Rel 4 UTRAN	Will only request lossless or other	Will request lossless, seamless or other – can all be supported by UTRAN

If the handover is between UMTS Rel 4 and UMTS R99, we will have the following:

From	To	Rel 99 UTRAN + Rel 99 CN	Rel 99 UTRAN + Rel 4 CN	Rel 4 UTRAN + Rel 99 CN	Rel 4 UTRAN + Rel 4 CN
Rel 99 UTRAN + Rel 99 CN		Lossless or other	Lossless or other	Lossless or other	Lossless or other
Rel 99 UTRAN + Rel 4 CN		Lossless or other	Lossless or other	Lossless or other	Lossless or other
Rel 4 UTRAN + Rel 99 CN		Lossless or other	Lossless or other	Lossless or other	Lossless or other
Rel 4 UTRAN + Rel 4 CN		Lossless or other	Lossless or other	Lossless or other	Lossless, seamless or other

If the handover is inter-system from UMTS Rel 4 to GPRS, then the same principle of Core Network bi-casting can be applied. This means real-time support could be provided for that type of handover, assuming that the SGSN in the GPRS network can use the latest version of GTP-C. There is no requirement for the GPRS SGSN to support an Iu interface for real-time support.

If the handover is inter-system from GPRS to UMTS Rel 4, then no relocation is triggered.

6.2.6 Summary: solution 2

In the Core Network bi-casting solution, handling of the real time data is done at the GGSN. Real time support requires that the GGSN is able to bi-cast the DL traffic to the target RNC. In the case of relocation involving only one SGSN, the SGSN may perform the bi-casting without involving the GGSN.

In any handover or relocation case, for DL there is one possible situation when frame gap or overlapping may happen. This occurs when the target RNC receives bi-casted DL traffic from the new GTP tunnel as well as the bi-casted traffic from the Iur, and switches from the latter to the former. This coincides with radio hard handover.

To support handovers for real time services from the PS domain with the Core Network bi-casting solution, procedural changes are required at the SGSN, GGSN, and RNC.

6.2.7 Open issues

7 Open items for all solutions

How the SGSN and the source RNC know which GTP-tunnels and RABs should be subject for real-time handling and which for Source RNC Data Forwarding (R99) i.e. NRT RABs?

Real time PDCP numbers are a RAN2 issue that has not been resolved yet. The questions to be solved with R2 include whether the RAB contexts (i.e. the sequence numbers) need to be between RNCs or not, and whether the header compression/stripping solution to be selected allows that transmission to UE continues via the Iur (i.e. effectively making the context in RELOCATION COMMIT message outdated).

According to the UMTS release 99 specifications, PDCP sequence numbers are exchanged with the UE as follows:

- UL: The target RNC can determine the UL sequence number which according to the header decompression information should be the next PDCP to be received from the UE. To do this, the RNC uses the PDU causing the RLC to re-establish.. This UL sequence number given by the RNC might be a few sequence numbers lower than the assumption of UE, since it has still maybe sent a few PDUs via source RNC after commit. UE should roll back the PDCP header compression and thus base the next compressed header of the next real-time PDU to the header information of the UL PDU considered as the last received by the target RNC (the indicated one - 1).
- DL: Similarly UE indicates in the PDU acknowledging the RLC re-establishment the DL Sequence number which PDU according to the DL header decompression information in the UE should next be received by UE. This is not generally the first forwarded but one of the first ones. Target RNC selects appropriate forwarded PDU and bases its header compression to the header of the 'indicated DL PDCP PDU-1'.

8 Comparison of the solutions

9 Agreements

This section is intended to list any agreements that have been reached in RAN3 on this work item.

10 Project Plan

10.1 Schedule

Date	Meeting	Scope	[expected] Input	[expected]Output

10.2 Work Task Status

	Planned Date	Milestone	Status
1.			
2.			

11 History

Document history		
V0.0.0	2000-07	Scope and document outline
V0.0.1	2000-07	First proposal for chapters 4, 5, 6 and 7
V0.1.0	2000-09	Changes agreed at RAN3#15.
V0.1.1	2000-10	Rapporteur's proposal to RAN3#16.
V0.2.1	2000-10	Changes agreed at RAN3#16.
V0.2.2	2000-11	Rapporteur's proposal to RAN3#17.
V0.3.0	2000-11	Proposed changes after RAN3#17, sent for e-mail comments.
Rapporteur for 3GPP RAN TR 25.936 is:		
Claire Mousset, Nortel Networks Tel: +44 1628 434285 Fax: +44 1628 434034 cmousset@nortelnetworks.com		
This document is written in Microsoft Word version 97 SR-2.		

**3rd Generation Partnership Project (3GPP);
Technical Specification Group (TSG) RAN 3;**

Handovers for real-time services from PS domain

UMTS TR25.936



Reference

<Workitem> (<Shortfilename>.PDF)

Keywords

<keyword[, keyword]>

3GPP

Postal address

Office address

Internet

secretariat@3gpp.org
Individual copies of this deliverable
can be downloaded from
<http://www.3gpp.org>

Copyright Notification

No part may be reproduced except as authorized by written permission.
The copyright and the foregoing restriction extend to reproduction in all media.

©
All rights reserved.

Contents

1	SCOPE	7
2	REFERENCES	7
3	DEFINITIONS, SYMBOLS AND ABBREVIATIONS	7
3.1	DEFINITIONS.....	7
3.2	SYMBOLS	8
3.3	ABBREVIATIONS.....	8
4	GSM AND UMTS R99 STATUS	9
4.1	GSM SOLUTION	9
4.2	UMTS R99 STATUS	9
5	REQUIREMENTS	9
5.1	GENERAL	9
5.2	PACKET LOSS	9
5.3	ROUND-TRIP DELAY	9
5.4	SPEECH INTERRUPTION.....	10
5.5	FREQUENCY OF INTERRUPTION.....	10
5.6	SECURITY.....	10
5.7	INTER-SYSTEM OPERATION.....	10
5.8	BACKWARDS COMPATIBILITY	10
5.9	GENERAL APPLICABILITY OF THE SELECTED SOLUTION.....	10
5.10	ALIGNMENT OF SELECTED SOLUTION WITH TRANSPORT MECHANISMS WITHIN REL4 CN.....	10
5.11	SUPPORT FOR MULTIPLE SIMULTANEOUS RABS WITH DIFFERENT QOS	10
6	STUDY AREAS.....	11
6.1	SOLUTION 1: REUSE OF RELEASE 99 PACKET DUPLICATION MECHANISM.....	11
6.1.1	<i>General</i>	11
6.1.2	<i>The main steps of Relocation for data forwarding</i>	11
6.1.3	<i>Specifications Impact</i>	17
6.1.4	<i>Interaction with other systems</i>	18
6.1.5	<i>Summary: solution 1</i>	18
6.1.6	<i>Open issues</i>	19
6.2	SOLUTION 2: CORE NETWORK BI-CASTING.....	20
6.2.1	<i>General</i>	20
6.2.2	<i>Relocation involving 2 SGSNs</i>	21
6.2.3	<i>Relocation involving only one SGSN</i>	29
6.2.4	<i>Specifications Impact</i>	36
6.2.5	<i>Interaction with other systems</i>	37
6.2.6	<i>Summary: solution 2</i>	38
6.2.7	<i>Open issues</i>	38
7	OPEN ITEMS FOR ALL SOLUTIONS	39
8	COMPARISON OF THE SOLUTIONS	39
9	AGREEMENTS	39
10	PROJECT PLAN	39
10.1	SCHEDULE.....	39
10.2	WORK TASK STATUS.....	39
11	HISTORY	40
1	SCOPE	7

2	REFERENCES	7
3	DEFINITIONS, SYMBOLS AND ABBREVIATIONS	7
3.1	DEFINITIONS	7
3.2	SYMBOLS	8
3.3	ABBREVIATIONS	8
4	GSM AND UMTS R99 STATUS	9
4.1	GSM SOLUTION	9
4.2	UMTS R99 STATUS	9
5	REQUIREMENTS	9
5.1	GENERAL	9
5.2	PACKET LOSS	9
5.3	ROUND TRIP DELAY	9
5.4	SPEECH INTERRUPTION	10
5.5	FREQUENCY OF INTERRUPTION	10
5.6	SECURITY	10
5.7	INTER SYSTEM OPERATION	10
5.8	BACKWARDS COMPATIBILITY	10
5.9	GENERAL APPLICABILITY OF THE SELECTED SOLUTION	10
5.10	ALIGNMENT OF SELECTED SOLUTION WITH TRANSPORT MECHANISMS WITHIN REL4 CN	10
6	STUDY AREAS	11
6.1	SOLUTION 1: REUSE OF RELEASE 99 PACKET DUPLICATION MECHANISM	11
6.1.1	General	11
6.1.2	The main steps of Relocation for data forwarding	12
6.1.3	Specifications Impact	16
6.1.4	Interaction with other systems	17
6.1.5	Summary: solution 1	17
6.1.6	Open issues	18
6.2	SOLUTION 2: CORE NETWORK BI-CASTING	19
6.2.1	General	19
6.2.2	Relocation involving 2 SGSNs	20
6.2.3	Relocation involving only one SGSN	22
6.2.4	Specifications Impact	24
6.2.5	Interaction with other systems	24
6.2.6	Summary: solution 2	24
6.2.7	Open issues	24
7	OPEN ITEMS FOR ALL SOLUTIONS	25
8	COMPARISON OF THE SOLUTIONS	25
9	AGREEMENTS	25
10	PROJECT PLAN	25
10.1	SCHEDULE	25
10.2	WORK TASK STATUS	25
11	HISTORY	26

Intellectual Property Rights

Foreword

This Technical Report (TR) has been produced by the 3rd Generation Partnership Project (3GPP), Technical Specification Group RAN.

The contents of this TR are subject to continuing work within 3GPP and may change following formal TSG approval. Should the TSG modify the contents of this TR, it will be re-released with an identifying change of release date and an increase in version number as follows:

Version m.t.e

where:

- m indicates [major version number]
- x the second digit is incremented for all changes of substance, i.e. technical enhancements, corrections, updates, etc.
- y the third digit is incremented when editorial only changes have been incorporated into the specification.

1 Scope

The purpose of the present document is to help the relevant 3GPP groups to specify the changes to existing specifications, needed for the introduction of the "Handover for real-time services from PS domain" Building Block for Release 2000.

The purpose of this R00 work task is to define the relocation procedure to be used when real time services are supported in the PS domain.

The intention with this work item is to provide support for services such as voice over IP and multimedia over IP.

This TR focuses on the requirements for the solution. Possible solutions have been further studied and they are also described in this TR for comparison and evaluation against the requirements. In doing this work, RAN3 has identified some areas of study that are not primarily under RAN3's responsibility. These are mentioned here so that work can be coordinated with the other 3GPP groups.

Changes to the signalling protocols in UTRAN and CN interfaces have also been studied at a high level.

This document is a 'living' document, i.e. it is permanently updated and presented to all TSG-RAN meetings.

2 References

The following documents contain provisions which, through reference in this text, constitute provisions of the present document.

- References are either specific (identified by date of publication, edition number, version number, etc.) or non-specific.
- For a specific reference, subsequent revisions do not apply.
- For a non-specific reference, the latest version applies.
- A non-specific reference to an ETS shall also be taken to refer to later versions published as an EN with the same number.

- [1.] UMTS 23.009: "3rd Generation Partnership Project (3GPP) Technical Specification Group Core Network; Handover Procedures".
- [2.] UMTS 23.060: "3rd Generation Partnership Project (3GPP) Technical Specification Services and System Aspects; GPRS; Service Description".
- [3.] Handovers for real-time services from PS domain, Work Item Description, TSG-RAN#7, submitted as RP-000127rev
- [4.] UMTS 25.413: "3rd Generation Partnership Project (3GPP) Technical Specification Radio Access Network; UTRAN Iu interface RANAP signalling".
- [5.] UMTS 21.905: "3rd Generation Partnership Project (3GPP) Technical Specification Services and System Aspects; Vocabulary for 3GPP specifications".

3 Definitions, symbols and abbreviations

3.1 Definitions

For the purposes of the present document, the following terms and definitions apply.

SRNS relocation:

The definition of [5] applies.

Handover:

The definition of [5] applies.

Hard handover:

The definition of [5] applies.

Relocation, or Relocation of SRNS:

The definition of [4] applies.

Bi-casting:

The capability of a node to receive original data, and send this data in its original form over two different paths.

Duplication:

The capability of a node to receive original data, and send this data over one path in its original form, as well as duplicating it and sending it in a different form over a different path. The duplicated data is in a different form than the original data received.

3.2 Symbols

3.3 Abbreviations

For the purposes of the present document, the following abbreviations apply:

DL	Downlink
GGSN	Gateway GPRS Support Node
GTP	GPRS Tunnelling Protocol
N-PDU	Network PDU
PDCP	Packet Data Convergence Protocol
PDU	Protocol Data Unit
RLC	Radio Link Protocol
RNC	Radio Network Controller
RRC	Radio Resource Control
SGSN	Serving GPRS Support Node
UE	User Equipment
UL	Uplink

4 GSM and UMTS R99 status

4.1 GSM solution

Inter-BSC handovers in GSM are described in ref. [1].

The 2G systems have been optimized to minimize the interruption of speech during handovers. In DL the standards allow bi-casting from the MSC. In UL this is achieved by fast radio resynchronization by the UE. Typical values are in the range of 60 to 120 ms in UL.

4.2 UMTS R99 status

Relocation in UMTS R99 for the CS domain is described in ref. [1].

Similarly to the GSM solution, the interruption of speech during relocation has been minimised. In DL the standards allow bi-casting from the MSC. In UL this is achieved by fast radio resynchronisation by the UE.

In UMTS R99, relocation for the PS domain is described in ref. [2].

It only specifies lossless relocation for non real-time services with high reliability.

The basic principle of the release 99 data forwarding is described as follows:

1. At a given point of time before execution of Relocation of SRNS, source RNC stops to transmit DL data to UE,
2. Source RNC starts to forward to the target RNC, via an GTP tunnel between the RNCs, all the GTP-PDUs which were not transmitted to UE and which continue to arrive from source SGSN to source RNC.
3. Source RNC should store all forwarded data also within source RNC, which ensures lossless operation in Relocation of SRNS failure cases.
4. Target RNC stores all GTP data forwarded from source RNC and when Serving RNC operation is started, target RNC starts the DL data transmission from the first forwarded GTP-PDU.

The R99 mechanism was originally designed for non-real-time services. The principle is that the N-PDUs are forwarded from the source RNC buffers to the target RNC. Data buffering is not adapted to real-time services, and means that interruption may exceed the requirement for real-time services.

5 Requirements

5.1 General

- General requirement is to minimise disruption to the user.

5.2 Packet loss

- Frame loss can already occur over the radio. Therefore when relocation occurs, any frame loss happens in addition to the frames lost over the radio. Therefore frame loss should be minimised.

Editor's note: In CS wireless speech, the FER must not be greater than 1% - does this put any requirement on our solution?

- The packet loss should be similar to what is achieved currently in 2G systems, or smaller.

5.3 Round-trip delay

- The round-trip delay should be minimised in real-time conversational services.
- The round-trip delay should be similar to what is achieved currently in 2G systems, or smaller.

- The global delay variation should be minimised.

5.4 Speech interruption

- The speech interruption should be similar to what is achieved currently in 2G systems, or smaller.

5.5 Frequency of interruption

- The number and frequency of interruption perceived by the user should be minimised.

5.6 Security

Editor's Note: This section is intended to list any security requirements for the real-time handover solution.

5.7 Inter-system operation

Editor's Note: This section is intended to list any requirements for the real-time handover solution due to operation with other systems such as GERAN, UTRAN R99, GSM/GPRS. This is subject to information availability for these other systems.

5.8 Backwards compatibility

Editor's Note: This section is intended to list any requirements for the real-time handover solution in order that it be backwards compatible with current solutions used in UMTS R99, and GSM/GPRS.

5.9 General applicability of the selected solution

It is required, that a unique solution will be finally selected supporting

- hard handover ("UE involved")
- SRNS Relocation ("UE not involved")
- inter-system operation (GERAN<->UTRAN) and
- intra-system operation (GERAN, UTRAN).

The solution shall, additionally, take care of an optimum support for intra-SGSN relocation as well as for the inter-SGSN case.

5.10 Alignment of selected solution with transport mechanisms within Rel4 CN

It is required that the selected solution takes into consideration transport mechanisms selected for the Rel4 ps CN.

If the Rel4 transport protocols for the ps domain utilises/requires resource reservation or initialisation of transport characteristics (like is done in cs domain), it shall be ensured that these mechanisms / initialisations / set-up are performed prior to the execution of relocation, as subsequent, delayed bearer setup [Note: whatever "bearer setup" will be called in an Rel4 ps domain] would cause an additional recognisable delay on the overall relocation process, which should be avoided.

5.11 Support for multiple simultaneous RABs with different QoS

It shall be capable to relocate/handover multiple RABs belonging to the same UE with the same signaling transaction on the Iu interface. These RABs, including the RAB for call control signaling, may belong to different QoS classes, and some of them may require lossless relocation/handover.

6 Study areas

6.1 Solution 1: Reuse of release 99 Packet Duplication mechanism

6.1.1 General

The idea of Solution 1 is to reuse the release 99 Data forwarding mechanism also for real time services requiring seamless Relocation of SRNS. Seamless Relocation of SRNS means that the interruptions to the data stream flow are minimised and are basically unnoticeable by the users.

The basic principle of SRNC duplication mechanism would be as follows:

1. At a given point of time before execution of Relocation, source RNC starts to duplicate DL GTP-PDUs: one copy is sent to local PDCP/RLC/MAC, and the other copy is forwarded to the target RNC.
2. Source RNC continues processing and sending DL data normally towards the UE.
3. Target RNC discards all forwarded GTP-PDUs arriving to target RNC until Serving RNC operation is started.
4. When target RNC takes over the serving RNC role, it starts to process the arriving DL GTP-PDUs and send DL data to the UE.

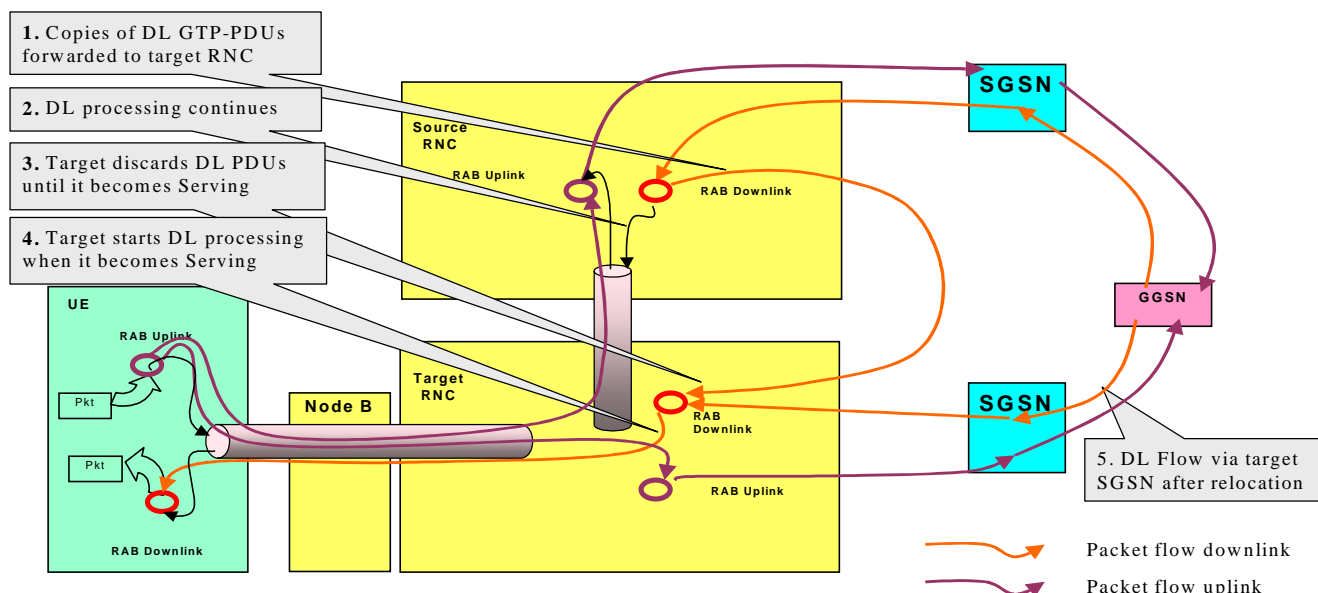

Figure 1: Packet flows during relocation, solution 1

The uplink flow is routed as in R99. The only addition compared to R99 solution is that the source RNC would, during an interim state, duplicate downlink flow to both the UE directly and to the forwarding tunnel.

6.1.2 The main steps of Relocation for data forwarding

[Note: Since for the solution 1 the procedures and mechanisms of performing Relocation of SRNS for all RABs from PS domain are the same, both the handling of lossless and Seamless RABs during Relocation of SRNS are described in this chapter.]

6.1.2.1 Preparation of Relocation of SRNS and Resource allocation

In this phase the UTRAN reserves resources for the relocation.

Specifically for Solution 1, it is assumed that lossless and seamless existing RABs are set to be "subject to data forwarding" in Relocation Command.

At the end of the preparation phase source RNC should:

- for lossless RABs; stop processing DL GTP-PDUs data
- for seamless RABs; continue to process and transmit DL data normally towards UE
- for lossless and seamless RABs; start duplicating all arrived and not acknowledged & arriving DL GTP-PDUs towards target RNC
- for lossless RABs; store all buffered & arriving DL GTP-PDUs

When data forwarding is started, target RNC should:

- for lossless RABs; store all arriving DL GTP-PDUs
- for seamless RABs; discard all arriving DL GTP-PDUs

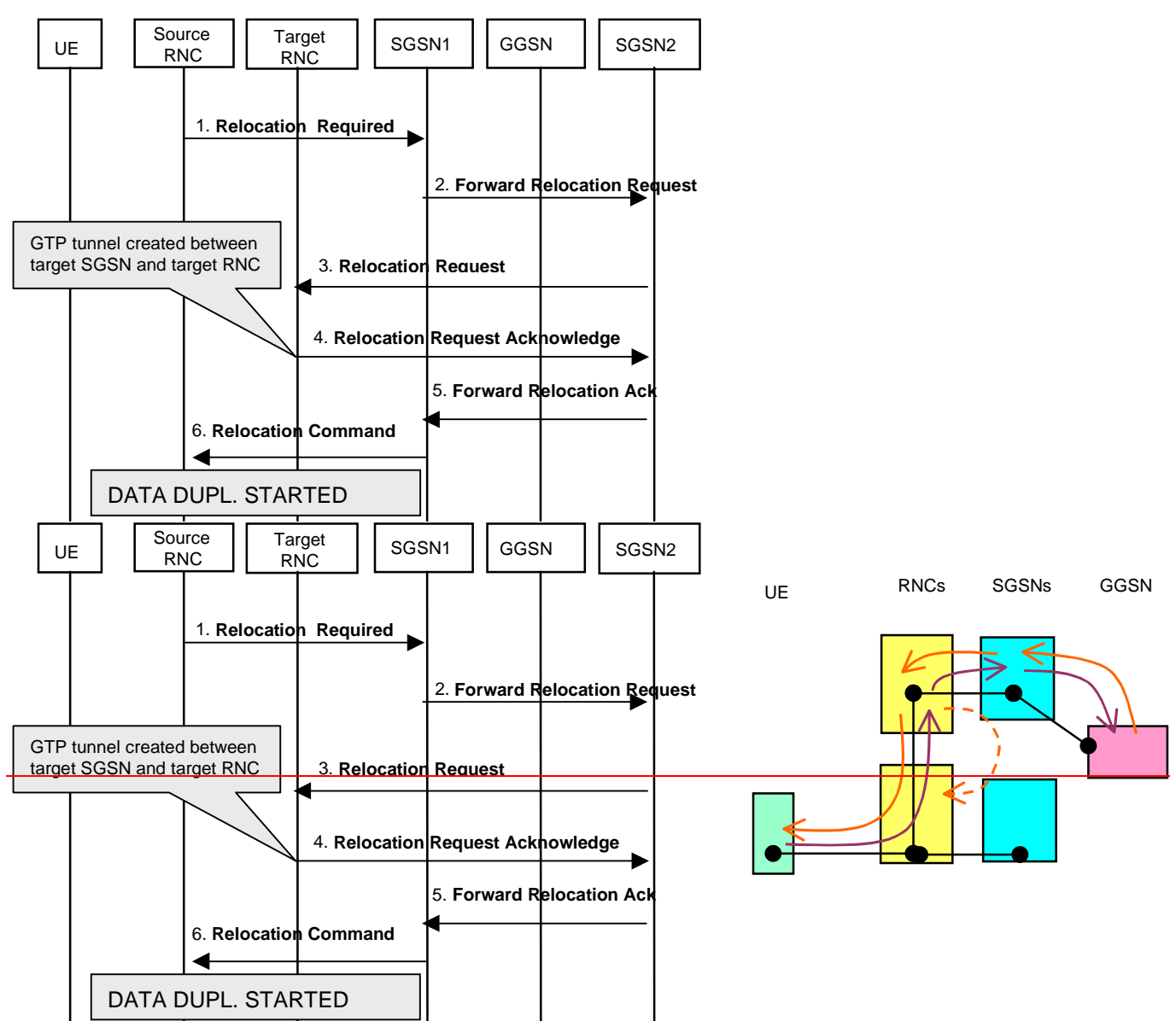

Figure 1 : Control Plane - Preparation of Relocation of SRNS and Resource allocation phase

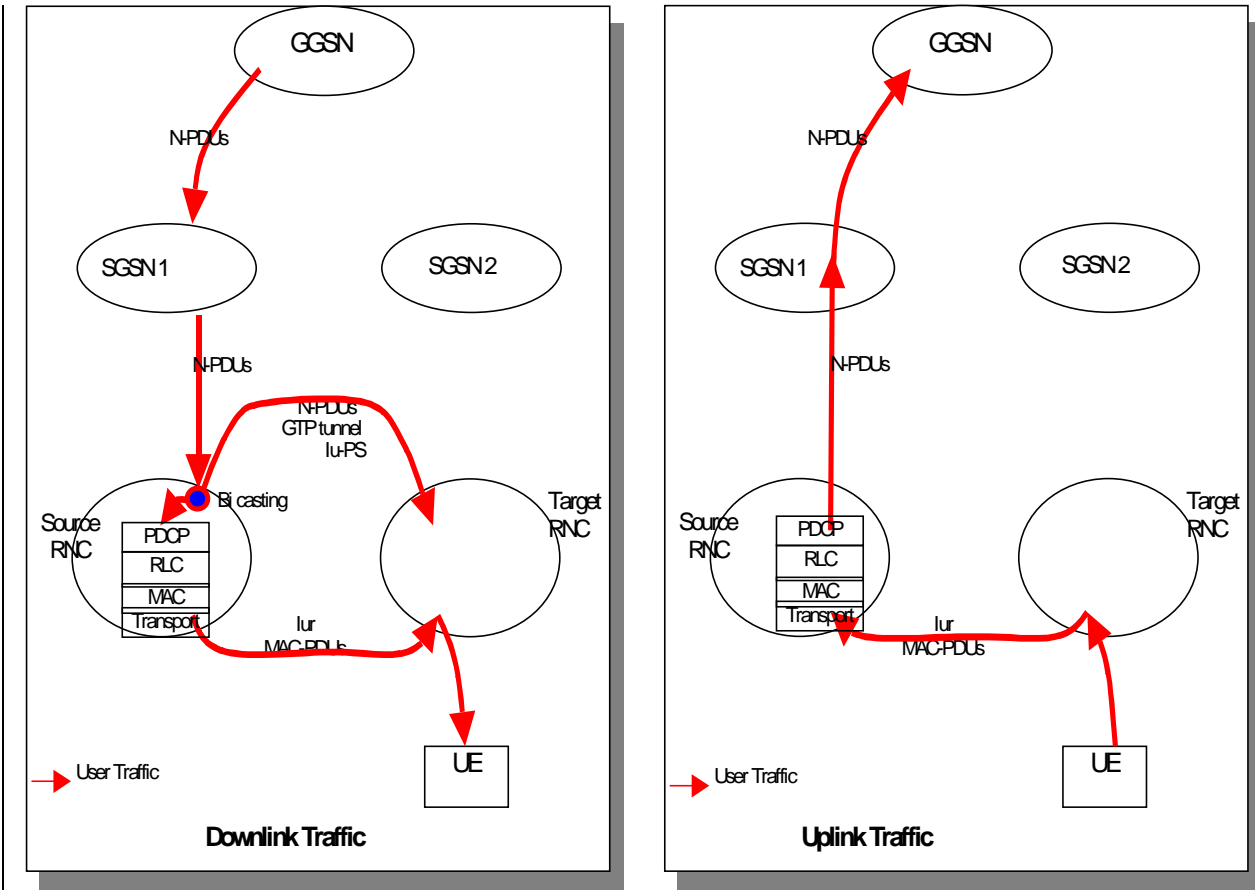

Figure 2 : User Plane - Preparation of Relocation of SRNS and Resource allocation (SRNS Relocation)

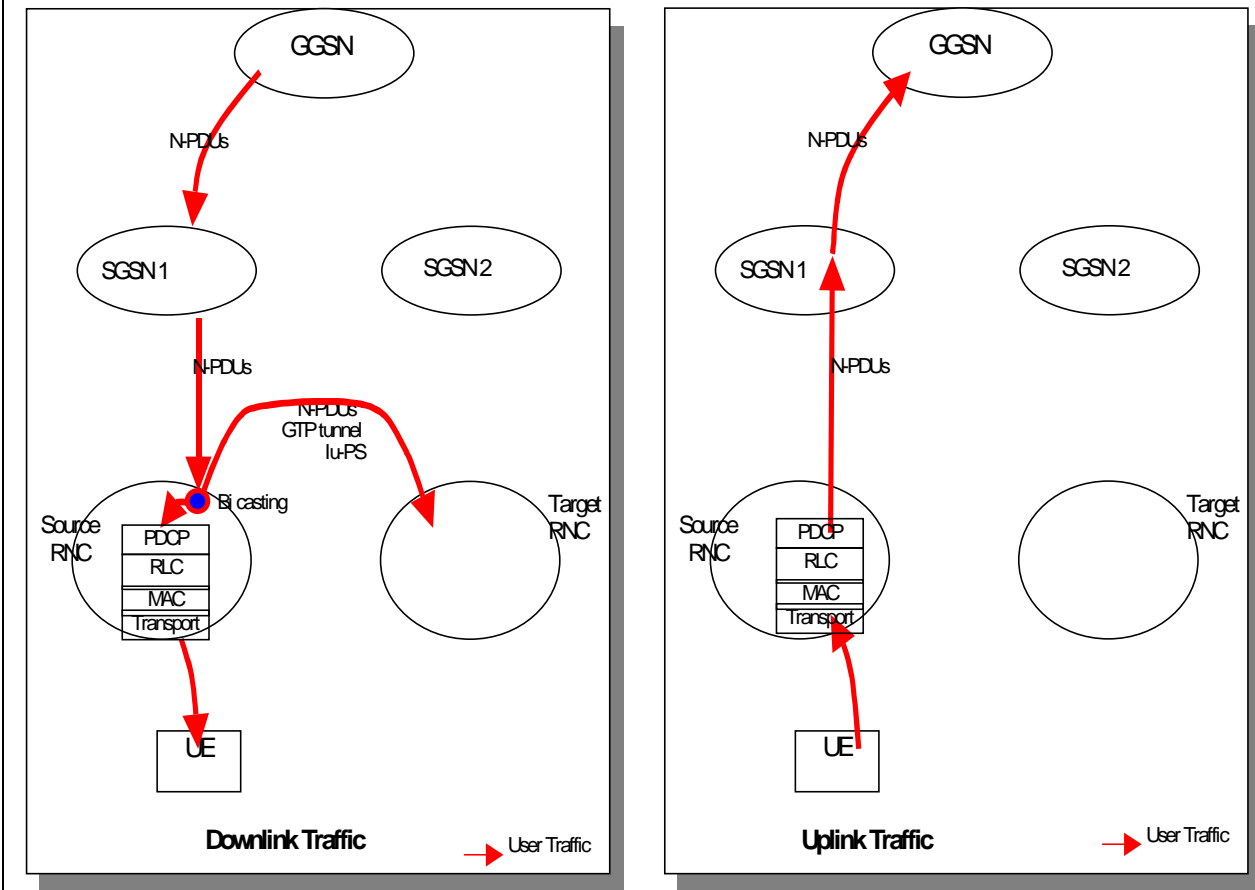

Figure 3 : User Plane - Preparation of Relocation of SRNS and Resource allocation (Hard Handover)

6.1.2.2 Moving the Serving RNC role to target RNC

When source RNC is ready for Relocation of SRNS Execution, it issues the SRNS Relocation Commit or in UE involved case commands the UE to make Hard Handover by appropriate RRC procedure.

For lossless RABs source RNC should forward the Sequence number information to target RNC as defined in Release 99.

After the reception of Relocation Commit from Iur, or in UE involved case when UEs access to target RL is detected by target RNC, target RNC takes over the Serving RNC role.

At this point of time target RNC should:

- for all lossless and seamless RABs; start UL reception of data and start transmission of UL GTP-PDUs towards CN via the new GTP tunnels. The radio interface protocols may need to be reset in order to start radio interface reception.
- for seamless RABs; start processing the arriving DL GTP-PDUs and start DL transmission towards the UE. The radio interface protocols may need to be reset in order to start radio interface transmission.
- for lossless RABs: start processing the buffered and arriving DL GTP-PDUs and start DL transmission towards UE. The radio interface protocols are reset as specified for Release 99 by R2.

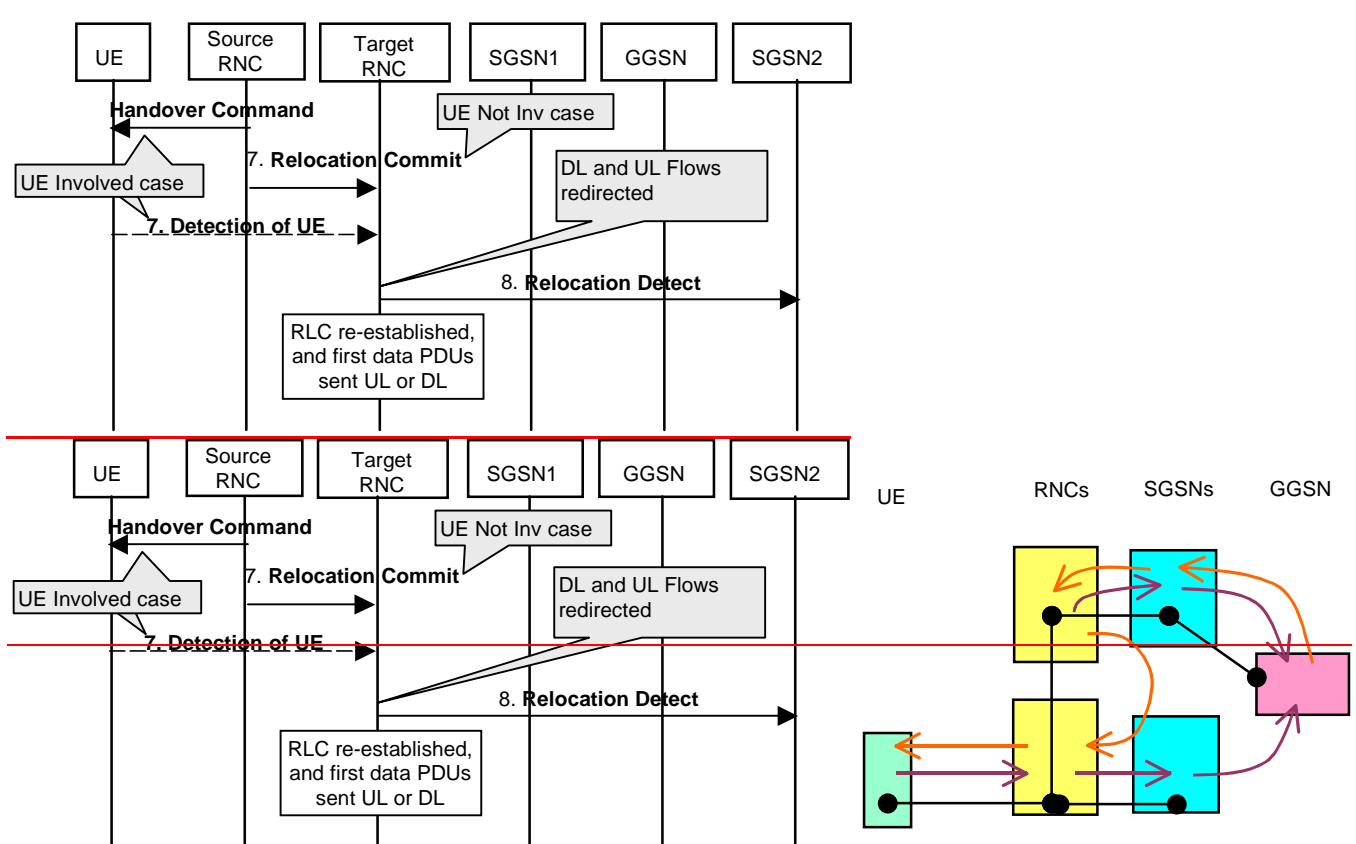

Figure 4 : Control Plane - Moving the Serving RNC role to target RNC

It is FFS how the target SGSN knows the IP address and the TEID of the GGSN.

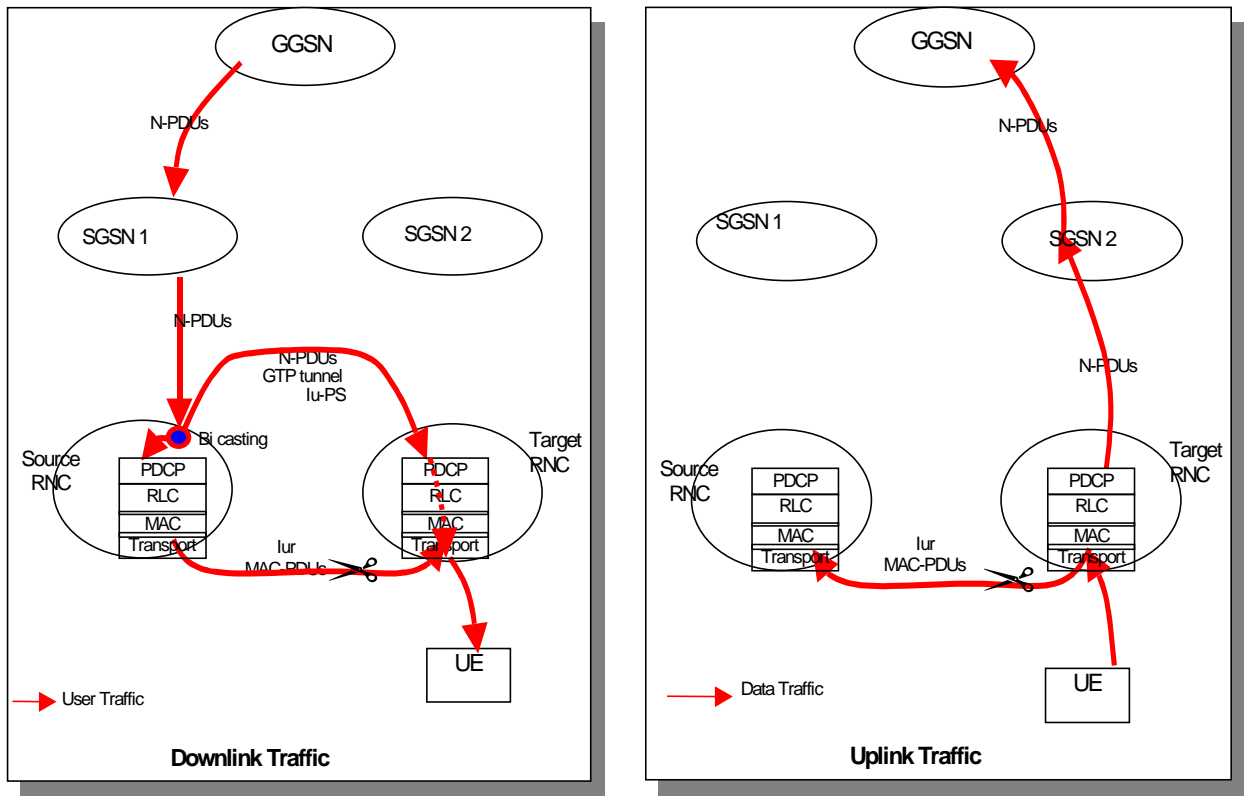

Figure 5 : User Plane - Moving the Serving RNC role to target RNC (SRNS Relocation)

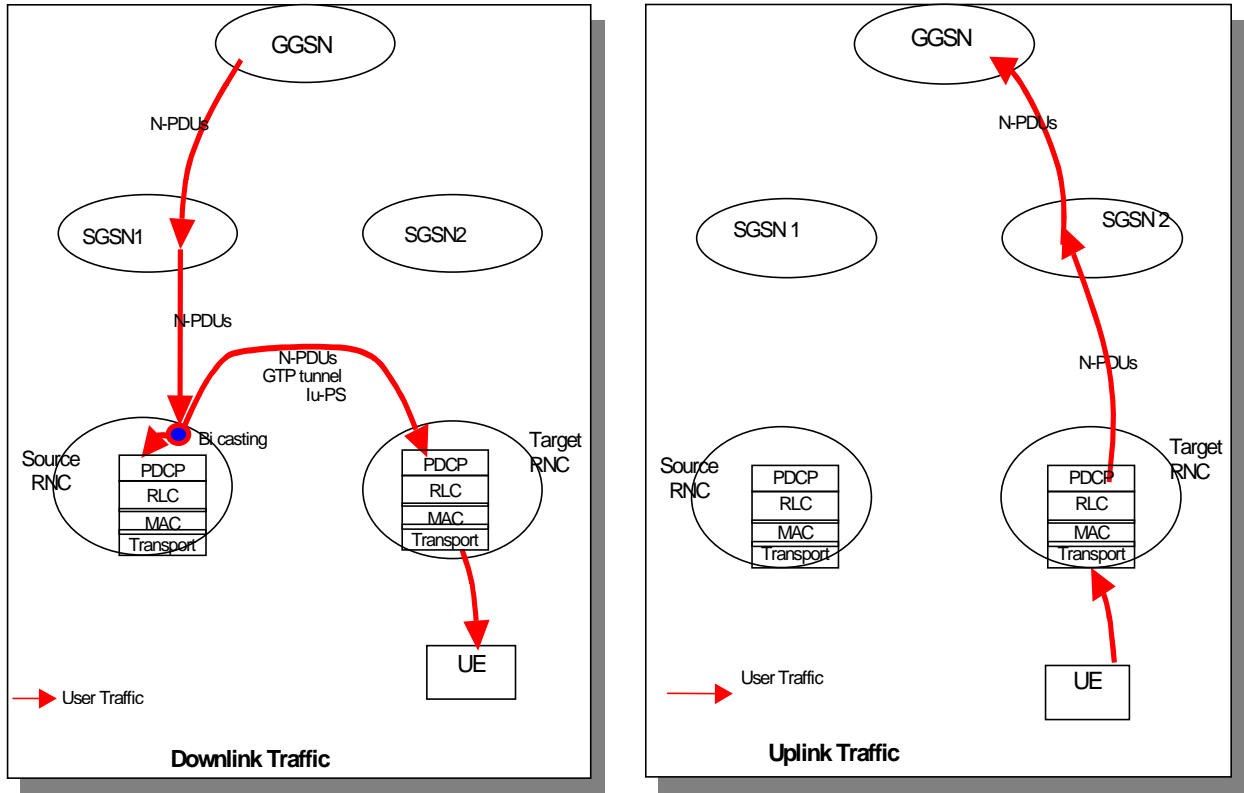

Figure 6 : User Plane - Moving the Serving RNC role to target RNC (Hard Handover)

6.1.2.3 Switching of DL flow in CN

In this phase, the DL GTP tunnel is updated between the SGSN and the GGSN so that the DL flow can use the new route.

The mechanism shown assumes that the DL GTP port used for a given RAB in target RNC is the same for all arriving GTP-PDUs regardless of their arrival route.

Only effect to the UTRAN may be the slightly earlier arrival time of DL-GTP PDUs from SGSN to target RNC. This is handled, as normal arrival time variation, by user plane buffering mechanisms existing in RNC. The additional buffering can be utilised and gradually reduced when the UE moves further from the new serving RNC and the Iur+Iub delays thus increase.

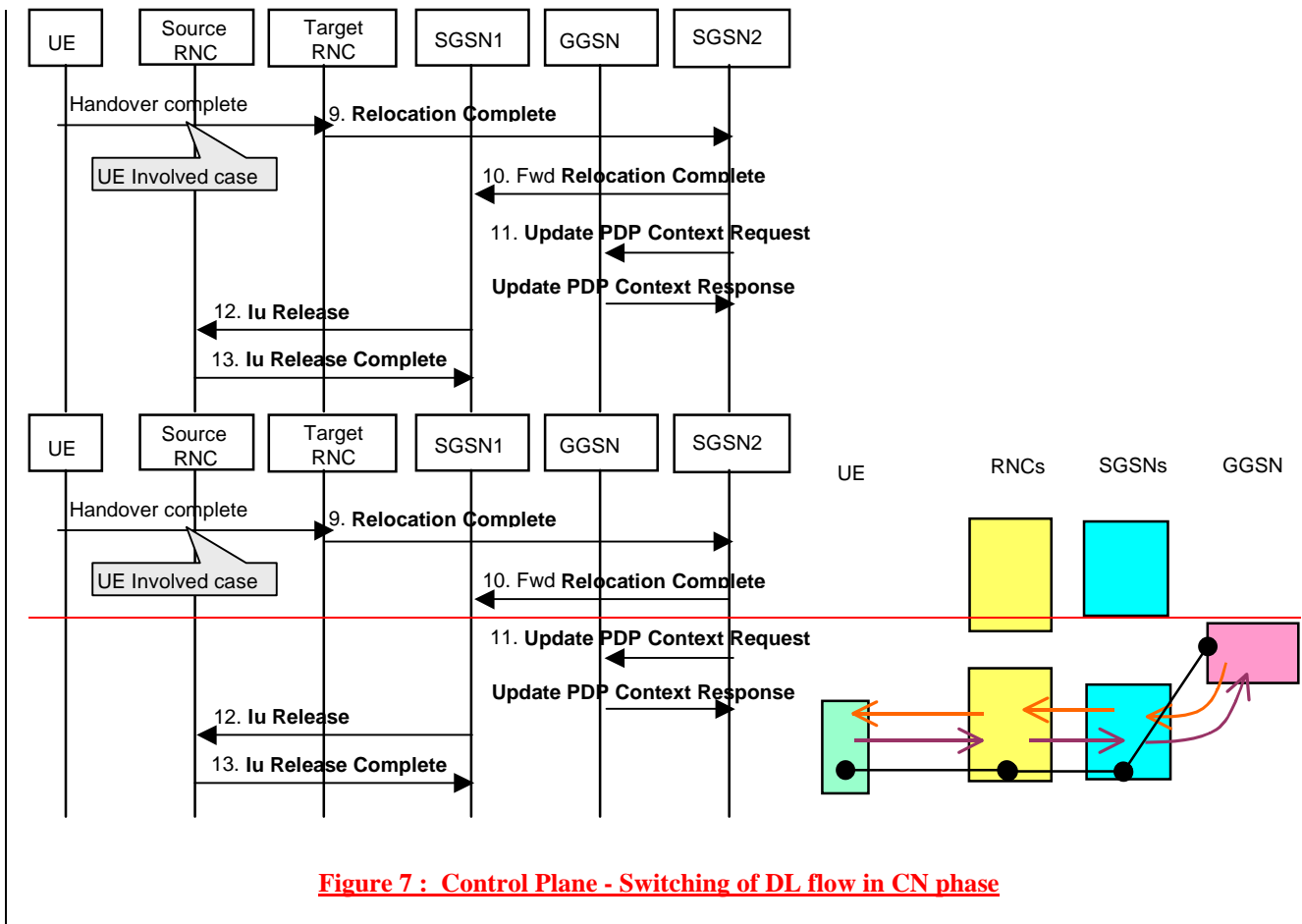

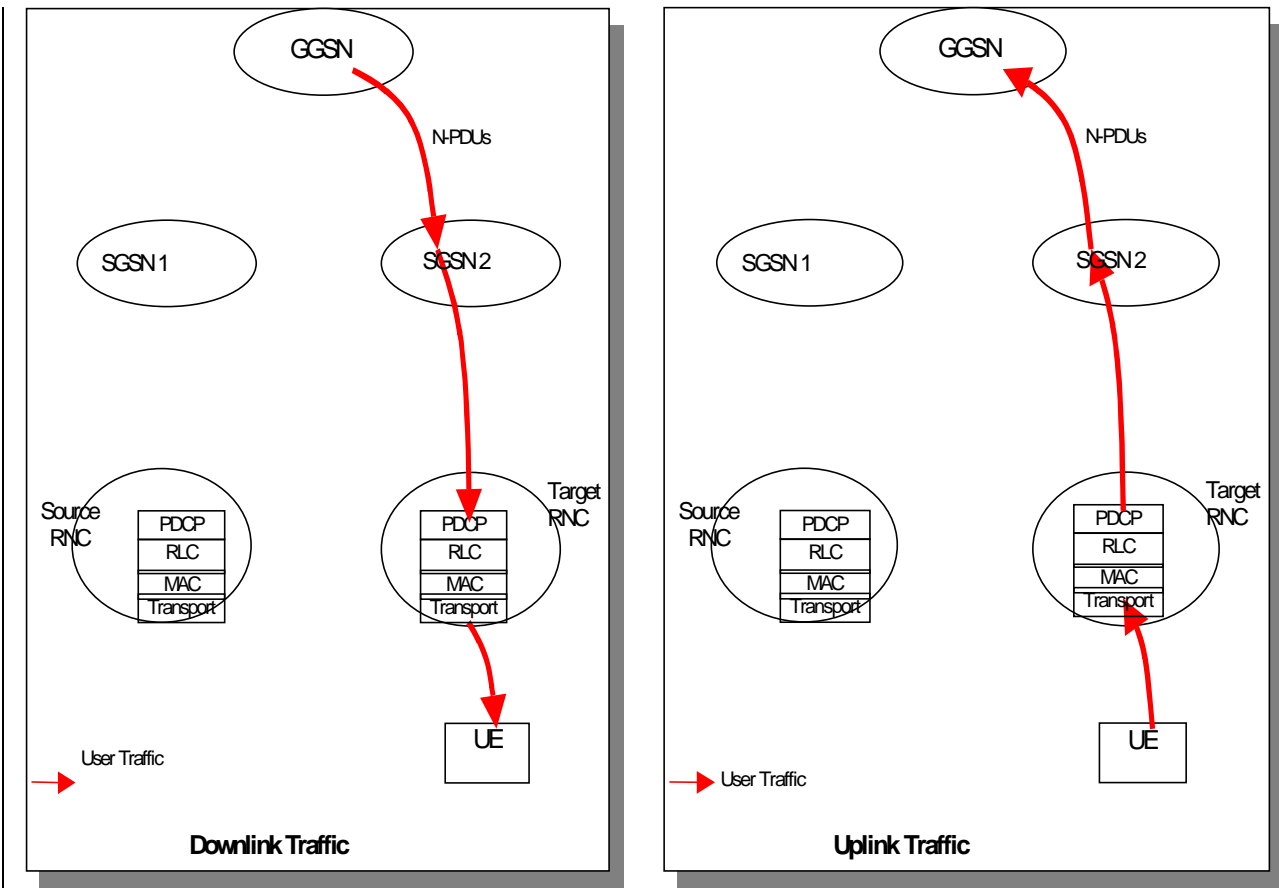

Figure 8 : User Plane - Switching of DL flow in CN

The forwarding tunnel(s) is released with timer supervision as in R99.

It is FFS if the GGSN updating has to wait until after Relocation Complete, or if it can take place earlier.

6.1.3 Specifications Impact

6.1.3.1 Impacts on RAN3 specifications

The Solution 1 reuses the Release 99 data forwarding mechanisms also for the seamless RABs from PS domain. Solution 1 does not require any new procedures, messages nor information elements to be introduced to any RAN 3 specification.

When specifying the release 99 RANAP it was decided by RAN3 to not specify the handling of user plane in application part specifications. This complete independence of user and control plane handling has however introduced some confusion and since the handling of user plane has direct impacts to the Relocation of SRNS characteristics for a given RAB maybe following informative example of user plane handling could be added to the RANAP specification.

X.X.X Example of User Plane handling during Relocation of SRNS

After Relocation Preparation is successfully terminated and before Relocation of SRNS execution is triggered the Source RNC should:

- for lossless RABs; stop processing DL GTP-PDUs data
- for seamless RABs; continue to process and transmit DL data normally towards UE

- for lossless and seamless RABs; start duplicating all arrived and not acknowledged & arriving DL GTP-PDUs towards target RNC
- for lossless RABs; store all buffered & arriving DL GTP-PDUs

After Relocation Resource Allocation procedure is successfully terminated but the serving RNC role is not yet taken over by target RNC and when DL user plane data starts to arrive to target RNC the target RNC should:

- for lossless RABs; store all arriving DL GTP-PDUs
- for seamless RABs: discard all arriving DL GTP-PDUs

When triggering the execution of Relocation of SRNS, source RNC should forward the Sequence number information to target RNC for all lossless RABs as defined in Release 99.

After reception of Relocation Commit from Iur, or in UE involved case when UEs access to target cell is detected by target RNC, target RNC takes over the Serving RNC role.

At this point of time the new Serving RNC should:

- for all lossless and seamless RABs; start UL reception of data and start transmission of UL GTP-PDUs towards CN via the new GTP tunnels. The radio interface protocols may need to be reset in order to start air interface reception.
- for seamless RABs; start processing the arriving DL GTP-PDUs and start DL transmission towards the UE. The radio interface protocols may need to be reset in order to start air interface transmission.
- for lossless RABs: start processing the buffered and arriving DL GTP-PDUs and start DL transmission towards UE. The radio interface protocols are reset as specified for Release 99 by RAN2.

6.1.3.2 Impacts on other groups' specifications

Depending on RAN 2 opinion, maybe addition of one parameter to RRC container could ensure the unambiguous operation of the solution 1. (See the chapter describing the Open Issues).

Stage 2 specification TS 23.060 has to be aligned with the selected solution for RT PS domain Relocation of SRNS.

There might be an impact on 29.060 on the usage of GGSN IP address and TEID.

No other impacts to any 3GPP specification in any other 3GPP groups are seen.

6.1.4 Interaction with other systems

This section is intended to explain how this solution will work with other systems such as GERAN, UTRAN R99, GSM and GPRS. This is subject to information availability for these other systems.

6.1.5 Summary: solution 1

This solution is based on making some procedure enhancements to the R99 mechanisms. During an interim state, the processing of the real time data is done at the source RNC so that the source RNC both sends the traffic to the UE, and forwards it to the target RNC.

This solution also assumes that considering the nature of RT services, there is no need to buffer any DL or UL traffic in the involved nodes.

The Solution 1 reuses the Release 99 data forwarding mechanisms also for the seamless RABs from PS domain. Solution 1 does not require any new procedures, messages nor information elements to be introduced to any RAN 3 specification.

For DL data of seamless RABs solution 1 introduces one instance for possible frame gapping/ overlapping and one additional possible instance for frame gapping/overlapping :

1. The frame overlap/gap may be introduced when target RNC takes the Serving RNC role and starts to produce the DL data from forwarded GTP-PDUs. In this case the estimated gap/overlap is equal to the delay difference between the transport bearer used for Iur DCH data stream and the transport bearer used for data forwarding GTP tunnel both of which are setup between the same source and target RNCs.

If the transport bearer delay difference is smaller than the air interface Transmission Time Interval (TTI) (10, 20, 40 or 80 ms depending on the service) the amount of gap/overlap is most likely non existent.

2. The additional frame gap may be introduced when the CN transport is optimised. In this case the gap will exist only if the delay via the optimised route is larger than the delay via the original route. In the more probable opposite case, the frame overlapping can be avoided by utilising appropriate sequence numbers in GTP headers.

6.1.6 Open issues

How the target SGSN knows the IP address and the TEID of the GGSN?

Does the GGSN updating have to wait until after Relocation Complete, or can it take place earlier?

6.2 Solution 2: Core Network bi-casting

6.2.1 General

The Core Network bi-casting mechanism handles real-time data from the GGSN/SGSN based on the model from GSM and the CS domain in UMTS R99.

The principle is that the packet anchor is at the GGSN/SGSN which acts as the equivalent of the three-party bridge in the CS domain MSC.

During the relocation, real-time downlink N-PDUs are duplicated at the GGSN and sent to the source RNC as well as to the target RNC. Additionally, at the moment the target RNC takes the role of serving RNC, it immediately begins sending uplink N-PDUs towards GGSN via the new SGSN.

The uplink flow is routed as in R99.

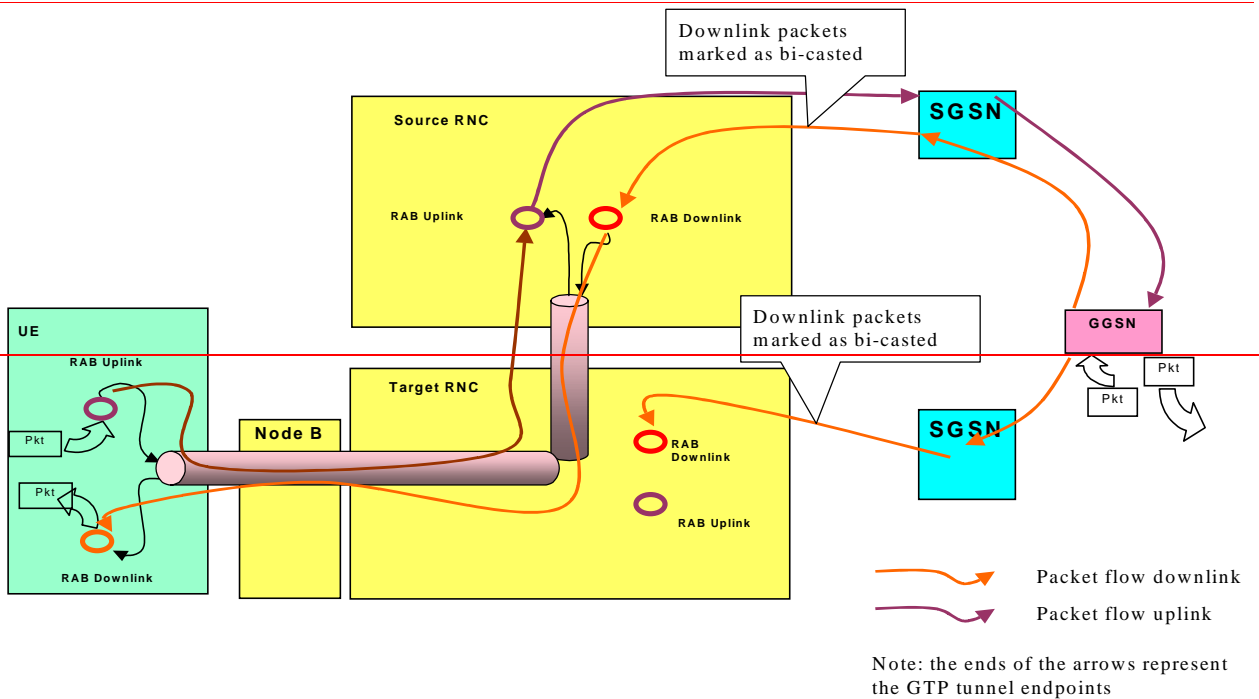
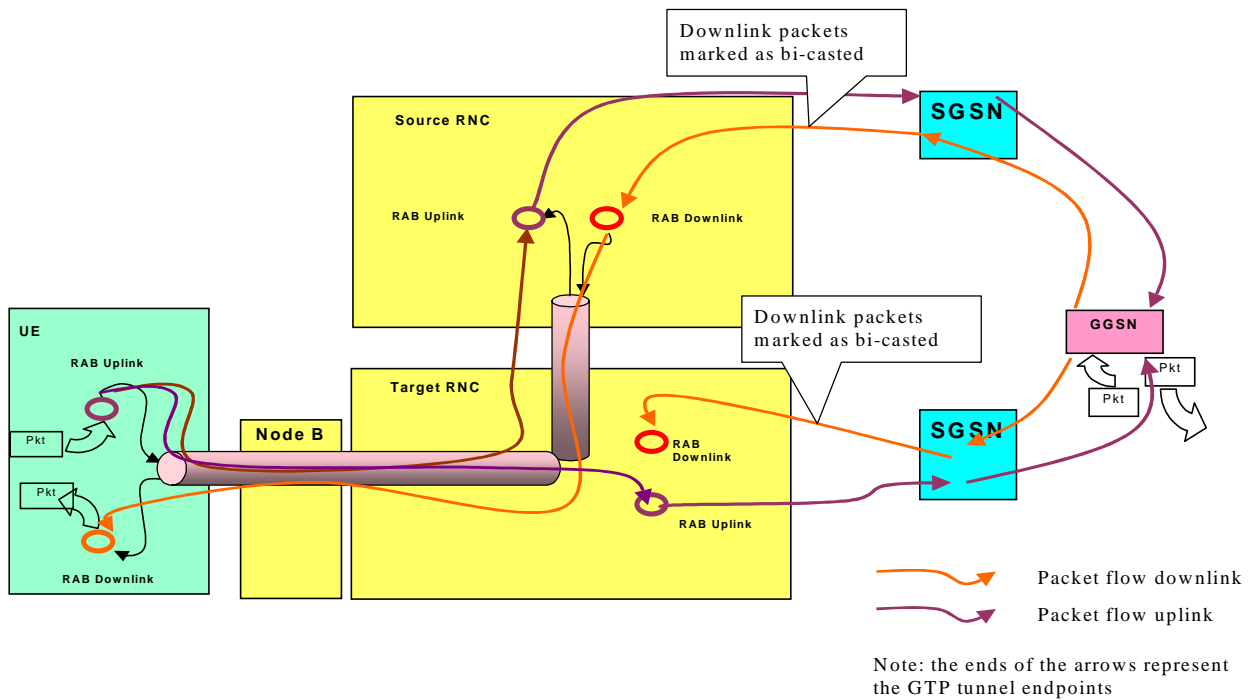

Figure 102: Packet flows during relocation, solution 2

6.2.2 Relocation involving 2 SGSNs

6.2.2.1 Preparation

In this phase the UTRAN reserves resources for the relocation. Then the source SGSN and source RNC are informed when the target RNC is ready. The GGSN is also instructed to start bi-casting downlink N-PDUs as part of the Relocation preparation process. As an implementation choice in the SGSN, this can happen in parallel with the signalling over the Iu interface, as shown in the picture below. This is because there is no need to get any information from the Relocation Request Acknowledge before initiating the Update PDP context.

This means that at the SGSN2, the Update PDP context response and the Relocation Request Ack can be received in any order, but have to be received by SGSN2 so that it can send a Forward Relocation Response to SGSN1.

The Update PDP context request/response is applicable to one PDP context only, therefore one will be done for each RAB. Each request can include the instruction to start bi-casting (seamless RAB), or not (lossless or other RAB).

Should the GGSN reject the bi-casting request, the entire relocation procedure shall be aborted. The original RAB/PDP Context continues unaffected by this abort. Likewise, any PDP Contexts which have begun bi-casting must be updated to revert back to the original configuration. This behaviour is described in more depth in the error handling procedure definition below.

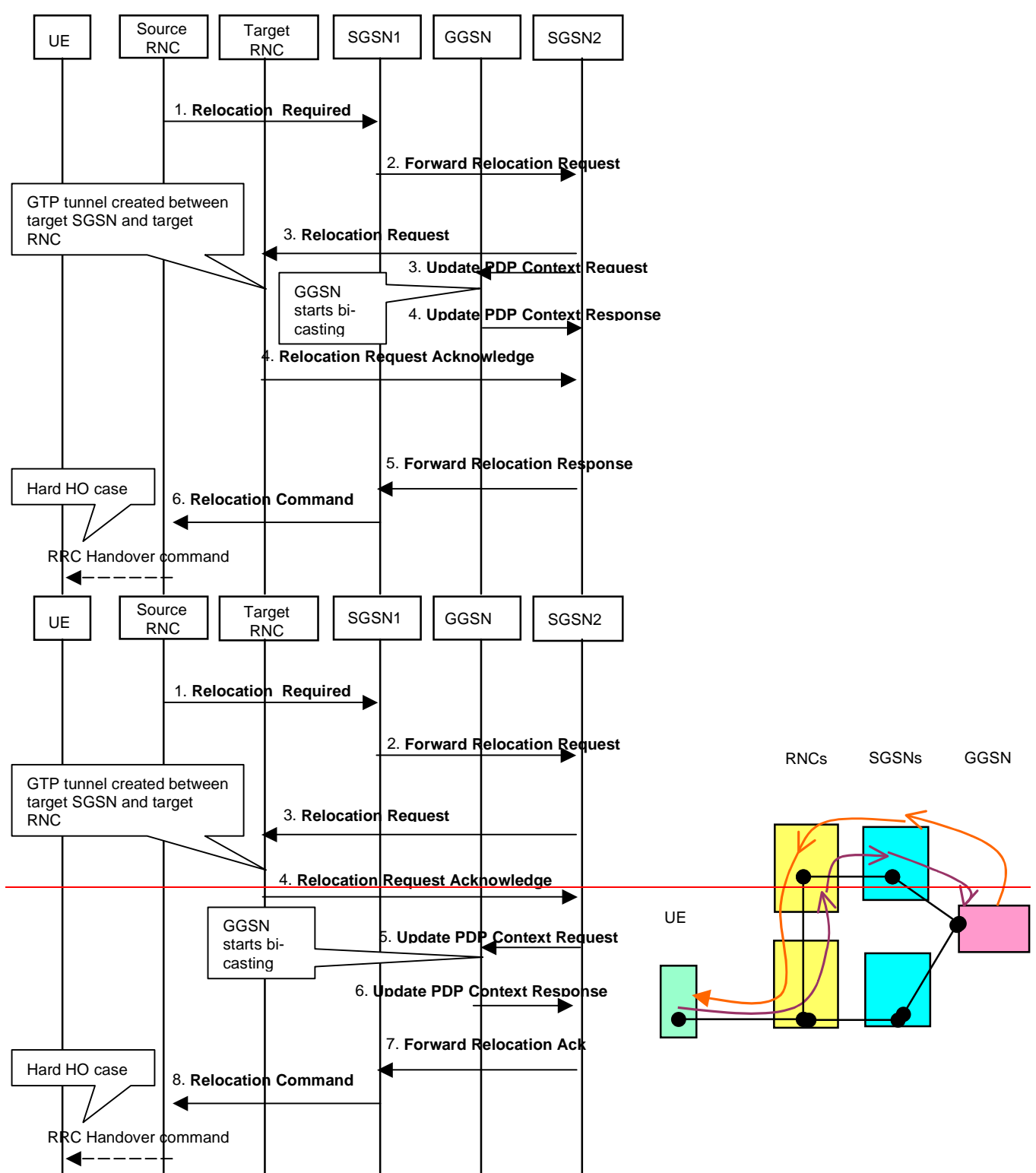

Figure 9 : Control Plane – Preparation involving 2 SGSNs

In the Forward Relocation Response, the RAB setup information is conditional because it is only applicable to lossless RABs. For seamless RABs, this RAB setup information is not included. For lossless RABs, this RAB setup information is included and it instructs SGSN1 of the RNC TEID and RNC IP address for data forwarding from source RNC to target RNC.

Handling of error cases in the Preparation phase:

If the SGSN1 decides to not accept the relocation from the source RNC after reception of message RELOCATION REQUIRED, the SGSN1 shall send a RELOCATION PREPARATION FAILURE message to the source RNC.

If the SGSN2 decides to not accept the relocation, it shall deactivate the PDP context and send a Forward Relocation Response to the SGSN1 as a response of the Forward Relocation Request, with a cause value other than 'Request accepted'. The SGSN1 can then send a RELOCATION PREPARATION FAILURE message to the source RNC.

In case the GGSN is not able to accept the request for the bi-casting, the Update PDP context response message shall be sent from the GGSN to the SGSN2 as a response of the Update PDP Context Request, with a new cause value 'Bi-casting not supported', or 'Bi-casting not possible'.

In this case the SGSN2 shall deactivate the PDP context and send a Forward Relocation Response to the SGSN1 as a response of the Forward Relocation Request, with the cause value from the GGSN ('Bi-casting not supported', or 'Bi-casting not possible'). The SGSN1 can then decide to:

1. send a RELOCATION PREPARATION FAILURE message to the source RNC. This cancels the relocation for all RABs
2. In the case that there are other RABs that do not need seamless treatment, the SGSN1 can send a RAB assignment request modifying the (new parameter) in the RAB parameters to be "other"

In case one of the GGSNs involved decide not to accept the request for relocation, the GGSN that can not accept the relocation will trigger the same process. The source RNC, when it receives RELOCATION PREPARATION FAILURE from the CN, shall initiate the Relocation Cancel procedure on the other Iu signalling connection for the UE if the other Iu signalling connection exists and if the Relocation Preparation procedure is still ongoing or the procedure has terminated successfully in that Iu signalling connection.

In case any of the SGSNs or GGSNs involved decide not to accept the relocation, and if the Iu signalling connection has been established or later becomes established, the SGSN2 shall also initiate the Iu Release procedure towards the target RNC with the cause value "Relocation Cancelled".

If the target RNC can not accept the relocation of SRNS or a failure occurs during the Relocation Resource Allocation procedure in the target RNC, the target RNC shall send RELOCATION FAILURE message to the SGSN2. The SGSN2 shall then deactivate the PDP context and send a Forward Relocation Response to the SGSN1 as a response of the Forward Relocation Request, with a cause value other than 'Request accepted'. The SGSN1 shall then send RELOCATION PREPARATION FAILURE message to the source RNC.

If the source RNC decides to cancel the relocation, it shall send RELOCATION CANCEL to SGSN1. The SGSN1 shall then terminate the possibly ongoing Relocation Preparation procedure towards the target RNC by sending Relocation Cancel Request to the SGSN2 which then initiate the Iu Release procedure towards the target RNC with the cause value "Relocation Cancelled".

Also if the GGSN had already been instructed to start bi-casting then the SGSN1 sends an Update PDP context request to the GGSN. This instructs the GGSN to stop bi-casting, and releases the newly created GTP tunnel between target SGSN and GGSN.

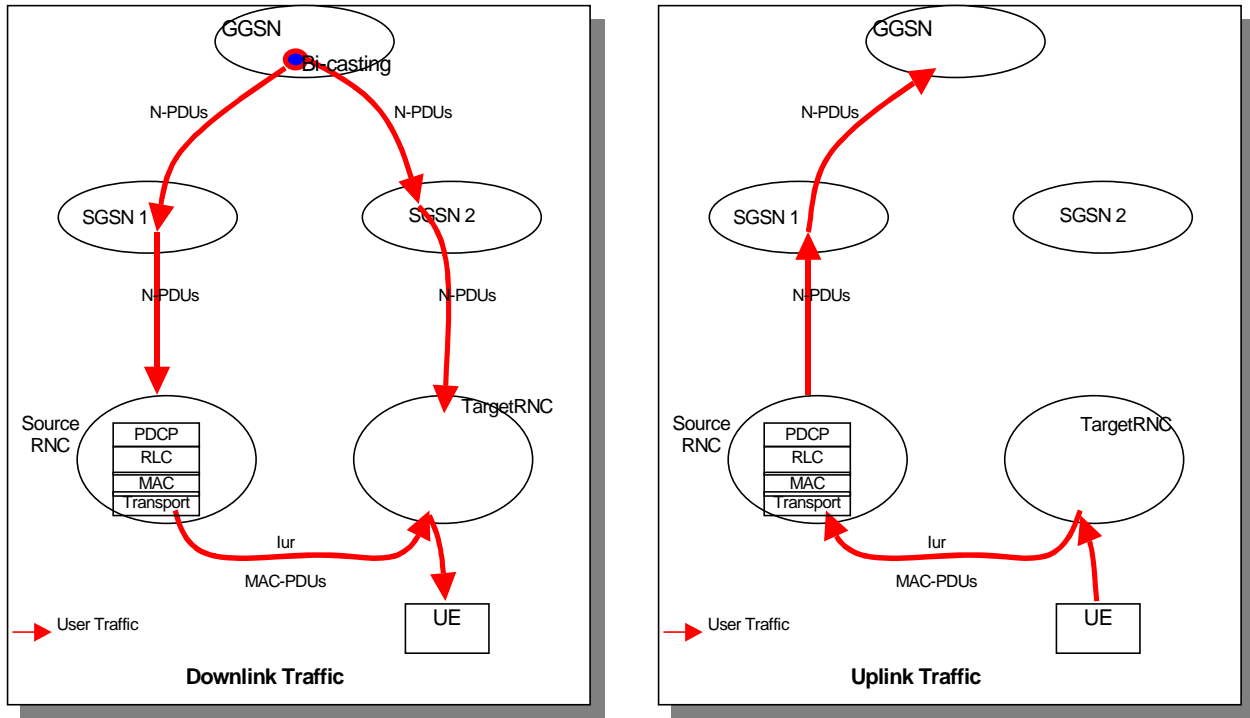

Figure 12: User Plane – Bi-casting of DL flow with 2 SGSNs involved (SRNS Relocation)

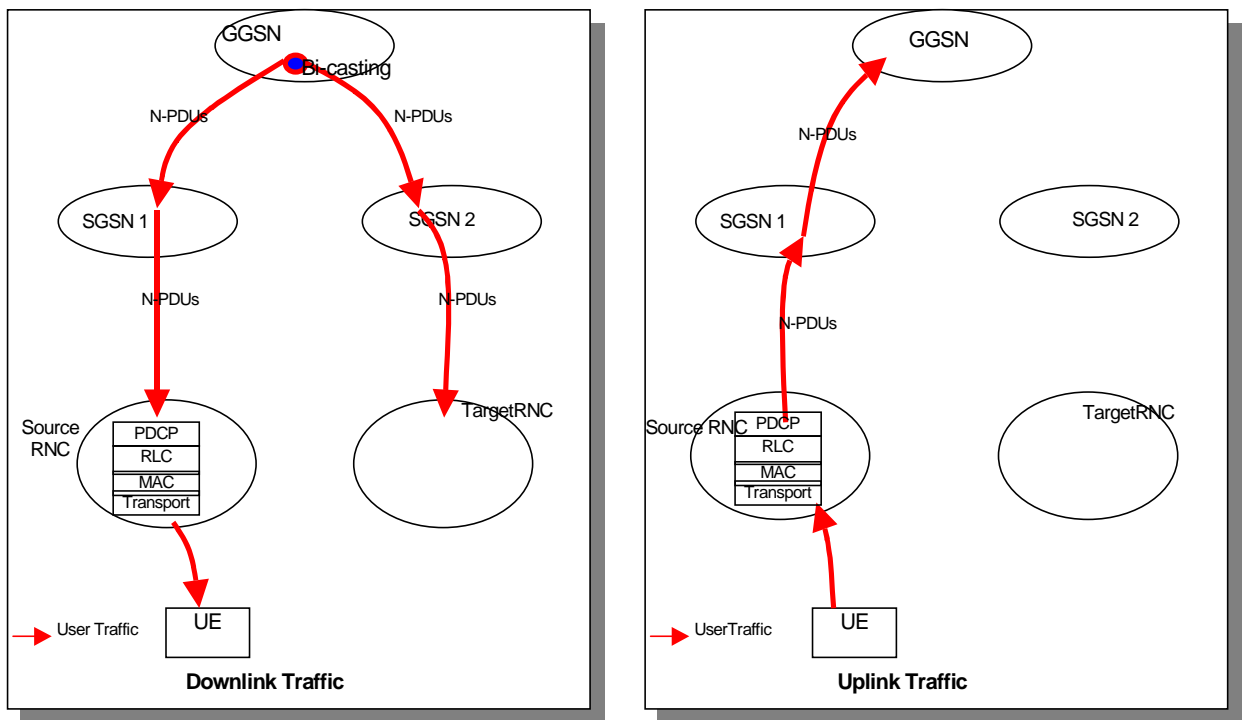

Figure 13: User Plane – Bi-casting of DL flow with 2 SGSNs involved (Hard Handover)

6.2.2.2 Bi-casting of DL flow and switching of UL flow

In this phase, DL traffic is bi-casted from the GGSN to the target RNC (as well as to the source RNC). Also at this point in both the hard handover and SRNS relocation cases, the UE sends UL traffic to the target RNC and UL traffic needs to be switched to the target SGSN and GGSN, using the new route.

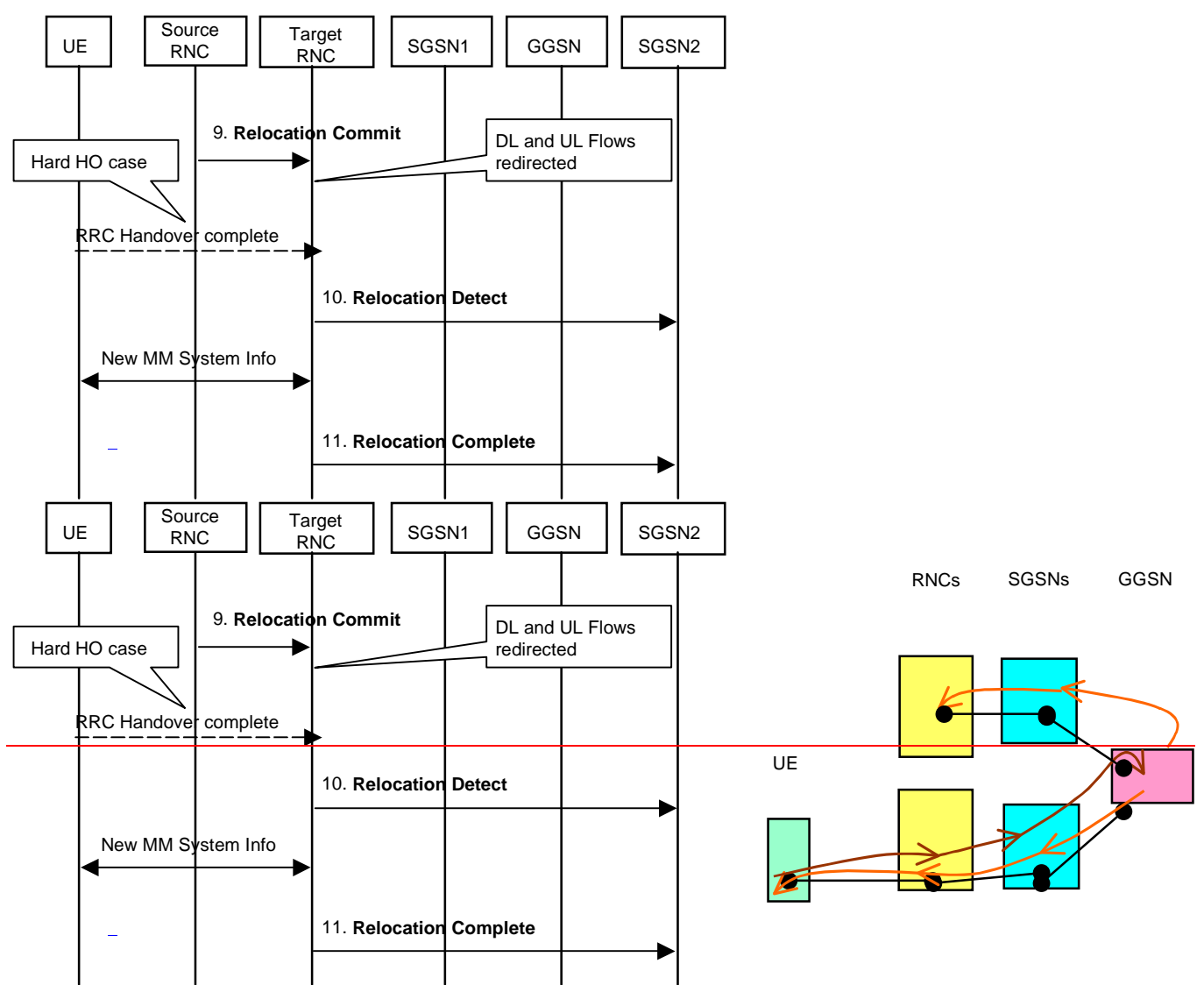

Figure 14 : Control Plane - Bi-casting of DL flow and switching of UL flow phase with 2 SGSNs involved

Handling of abnormal conditions in the Bi-casting phase:

If the RELOCATION DETECT message is not received by the SGSN before reception of RELOCATION COMPLETE message, the SGSN shall handle the RELOCATION COMPLETE message normally.

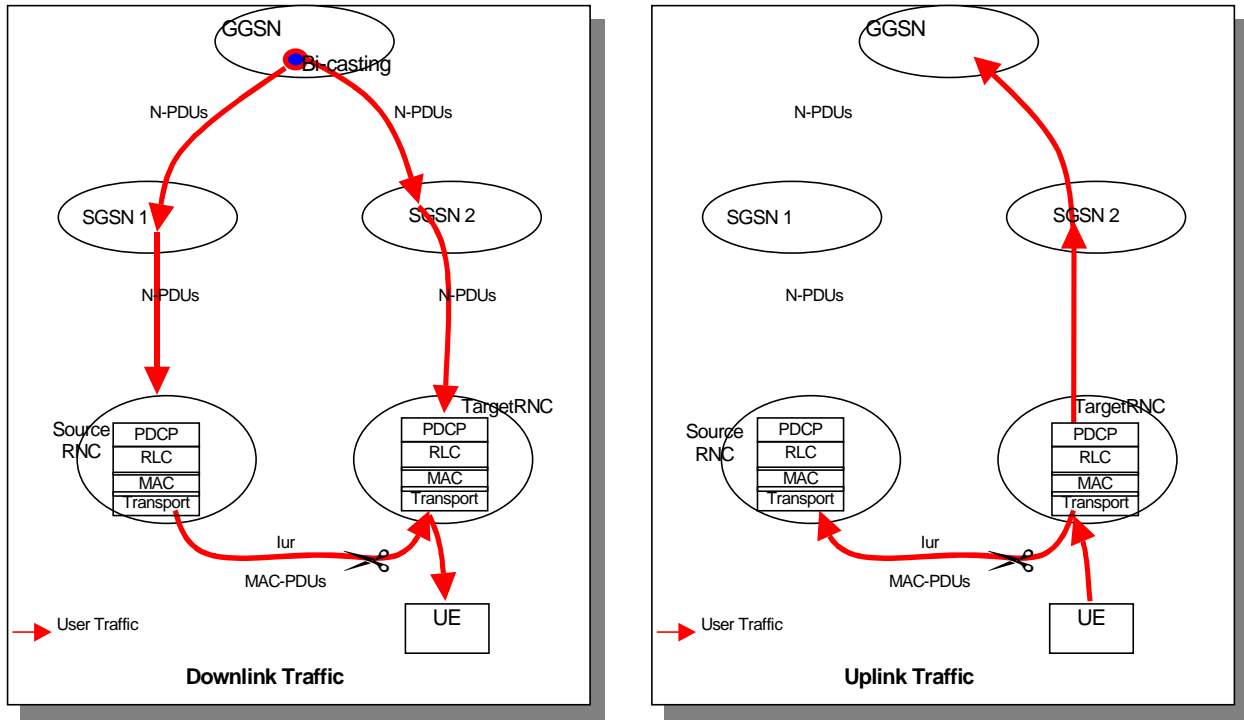

Figure 15: Moving the serving RNC role to target RNC with 2 SGSNs involved (SRNS Relocation)

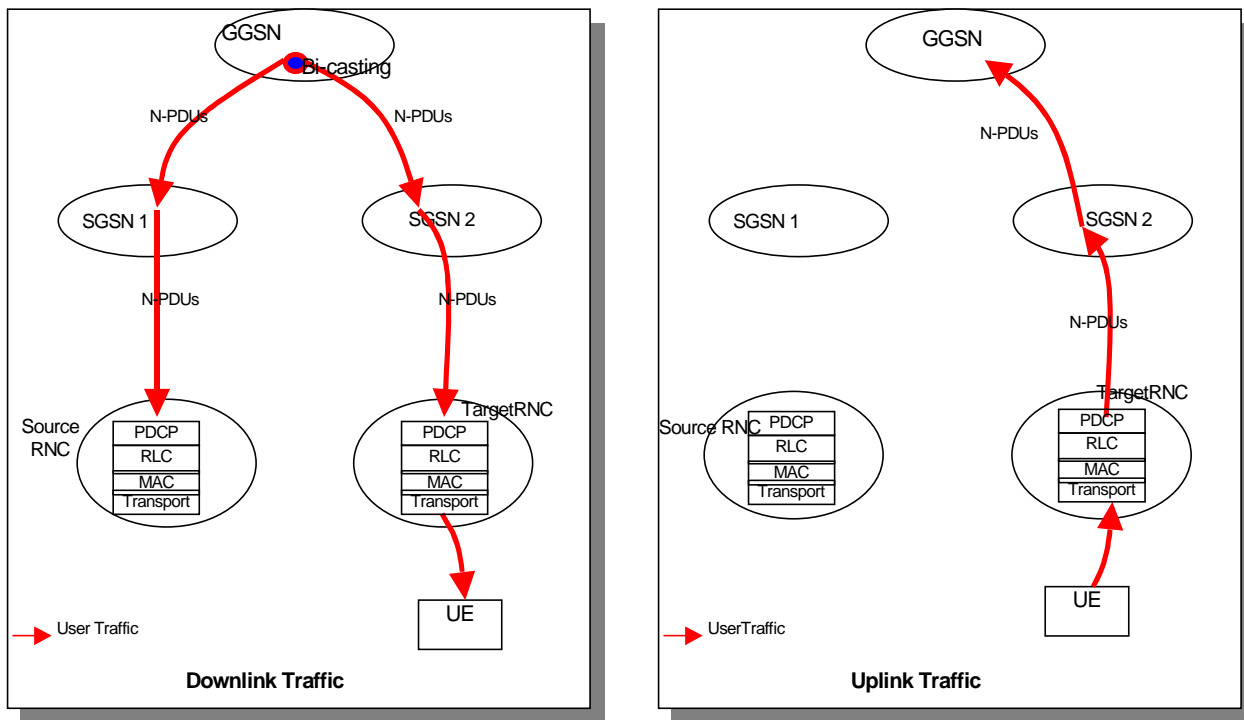

Figure 16 : Moving the serving RNC role to target RNC with 2 SGSNs involved (Hard Handover)

6.2.2.3 Completion

This is the completion of the signalling. Also, the GGSN is instructed to stop bi-casting downlink N-PDUs. At this stage, the relocation has effectively already been completed. Note that SGSN2 informs SGSN1 that the relocation is complete once all of the GGSNs involved have stopped the bi-casting. Then it informs SGSN1 to release the Iu connection towards the Source RNC.

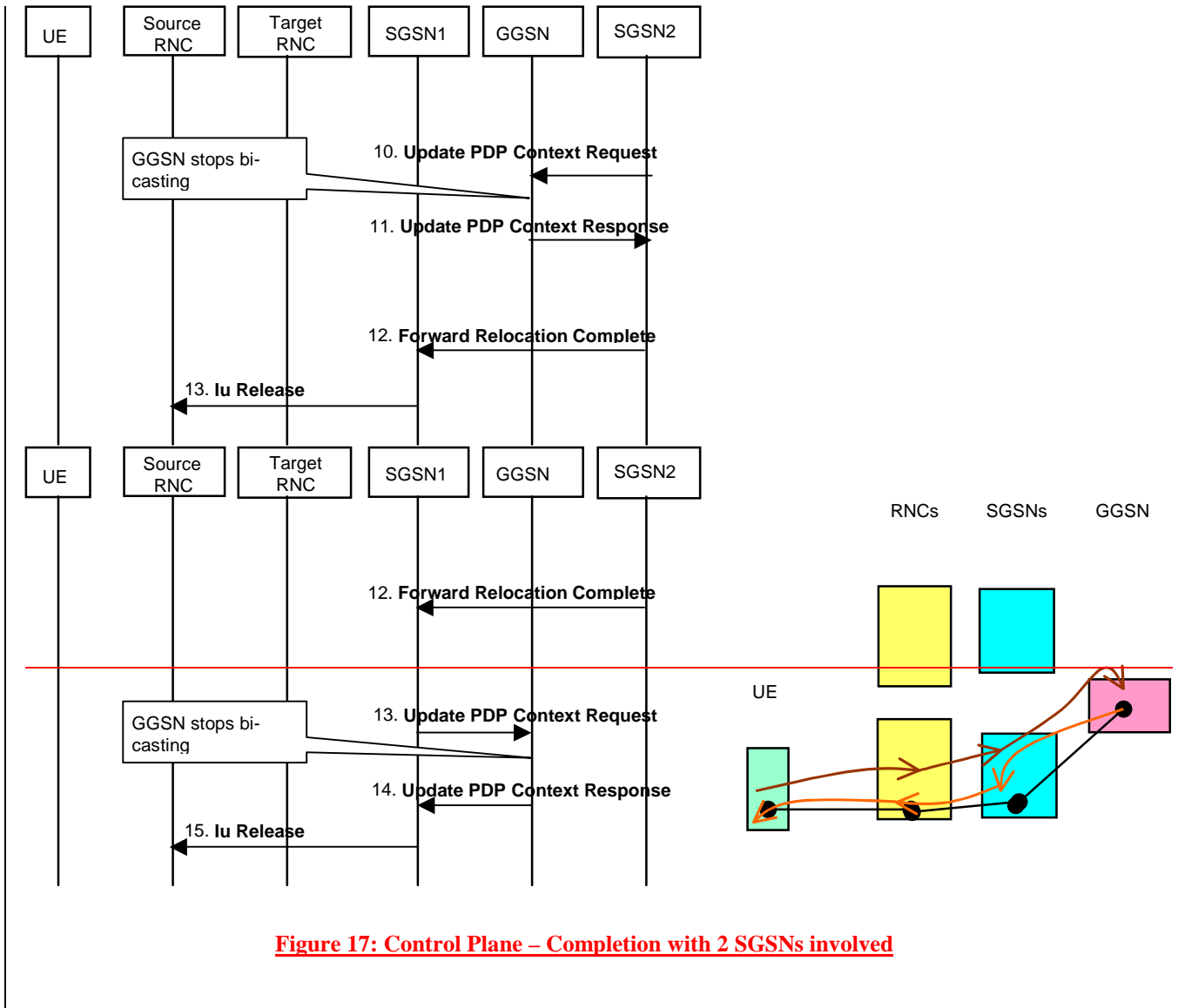

Figure 17: Control Plane – Completion with 2 SGSNs involved

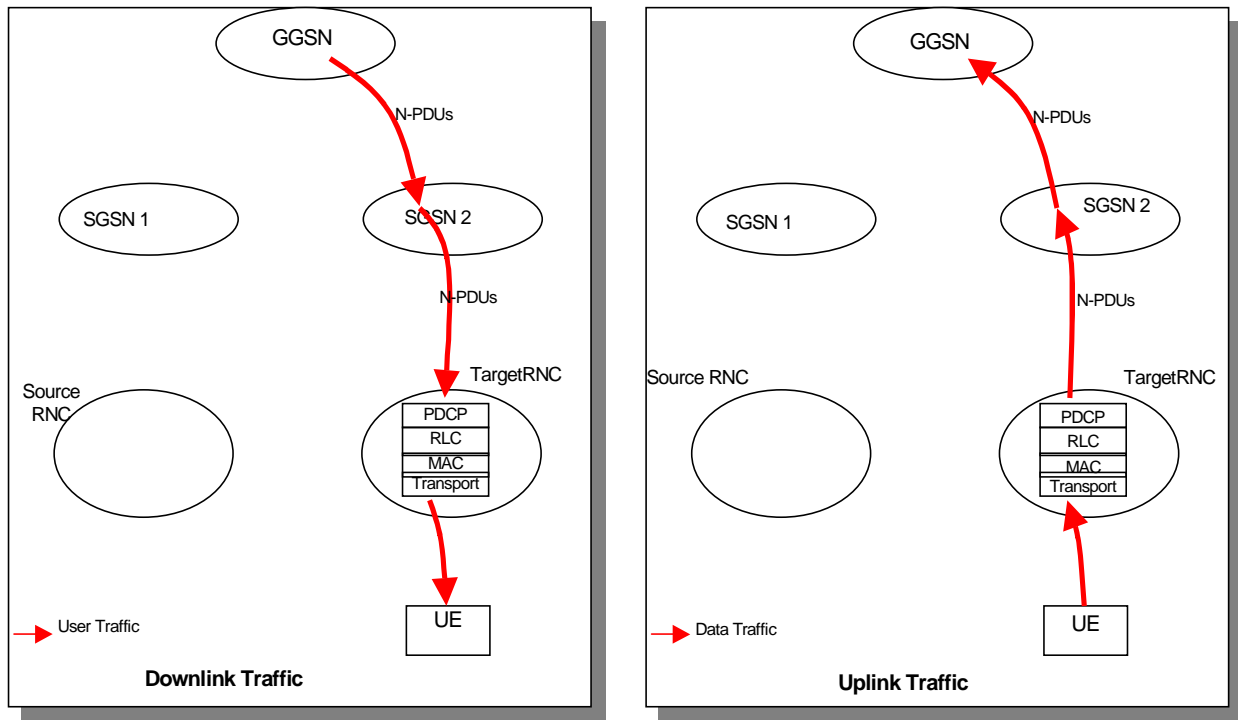

Figure 18: User Plane – Completion with 2 SGSNs involved

6.2.3 Relocation involving only one SGSN

In the case that the relocation involves only one SGSN, the flow of N-PDUs across the Gn interface does not need to be changed. Indeed, the tunnel switching point in the SGSN can serve as the anchor for the tunnel instead of the GGSN as proposed above.

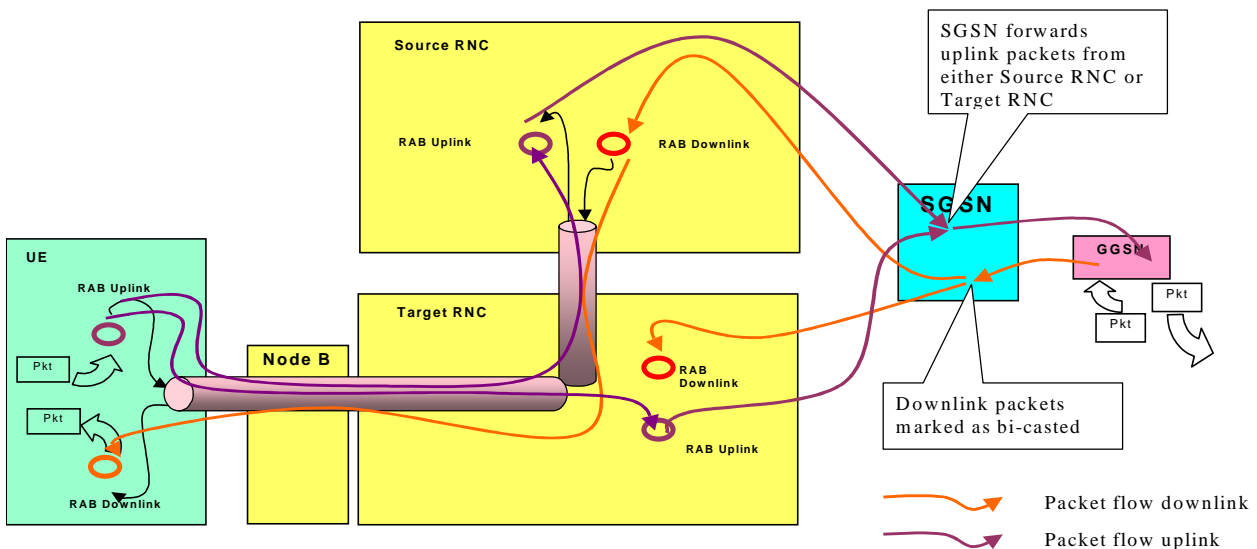

Figure 319: Packet flows during relocation with only one SGSN involved, solution 2

As illustrated in the above figure, the SGSN forwards N-PDUs from either the source RNC or the target RNC allowing the N-PDUs to start flowing from the DRNC as soon as possible after the switchover. The procedure is explained below with the change in operation when the GGSN is not involved.

6.2.3.1 Preparation

In this phase the UTRAN reserves resources for the relocation. Then the source SGSN and source RNC are informed when the target RNC is ready. The SGSN starts bi-casting downlink N-PDUs as part of the Relocation preparation process.

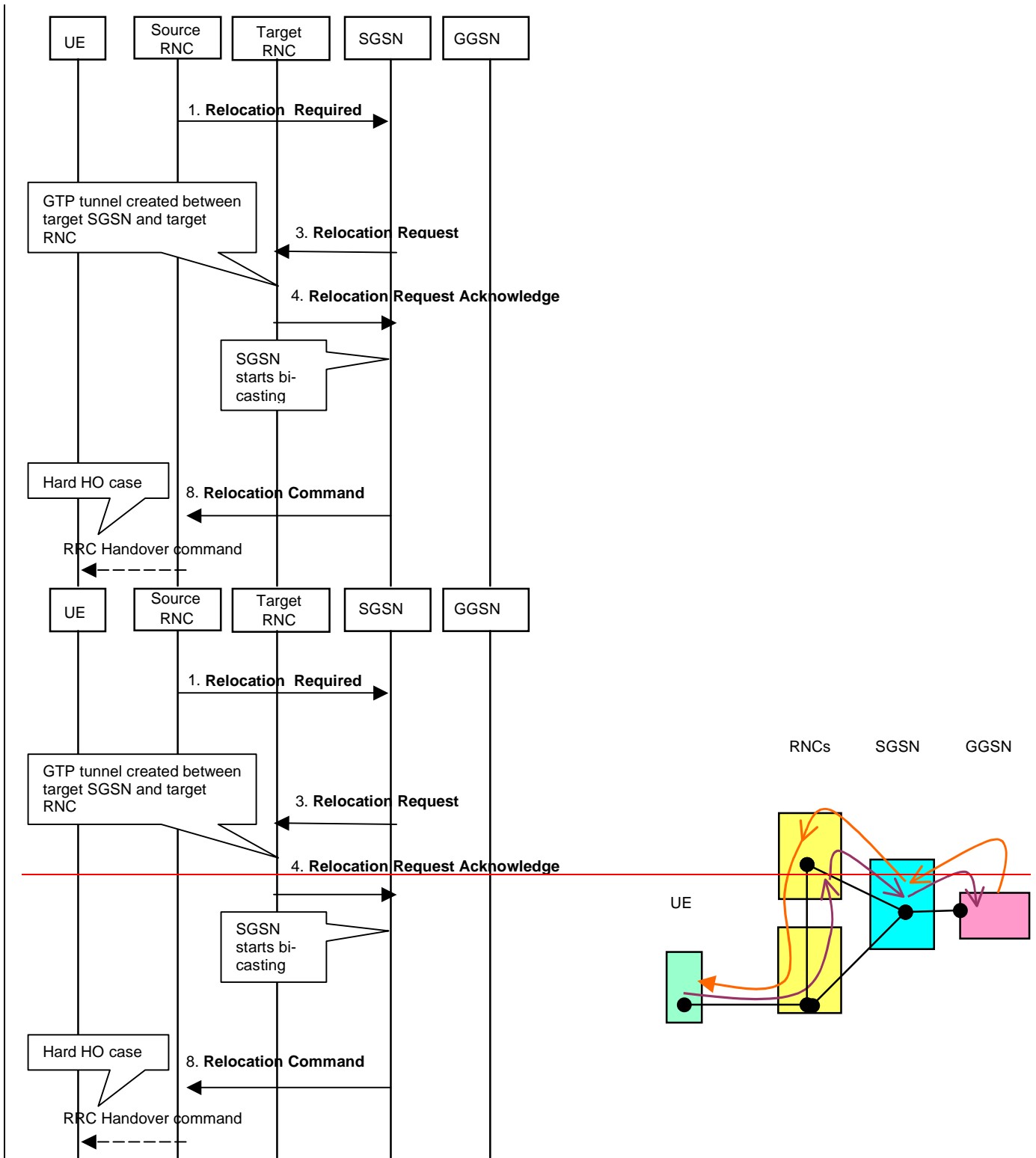

Figure 20: Control Plane – Preparation phase with only one SGSN

Handling of abnormal conditions in the Preparation phase:

If the SGSN decides to not accept the relocation from the source RNC after reception of message RELOCATION REQUIRED, the SGSN shall stop timer T_{RELOCalloc} and send a RELOCATION PREPARATION FAILURE message to the source RNC.

If the Iu signalling connection has been established or later becomes established, the SGSN shall also initiate the Iu Release procedure towards the target RNC with the cause value "Relocation Cancelled".

If the target RNC can not accept the relocation of SRNS or a failure occurs during the Relocation Resource Allocation procedure in the target RNC, the target RNC shall send RELOCATION FAILURE message to the SGSN. The SGSN shall then send RELOCATION PREPARATION FAILURE message to the source RNC.

If the source RNC decides to cancel the relocation, it shall send RELOCATION CANCEL to SGSN. The SGSN shall then terminate the possibly ongoing Relocation Preparation procedure towards the target RNC by initiating the Iu Release procedure towards the target RNC with the cause value "Relocation Cancelled".

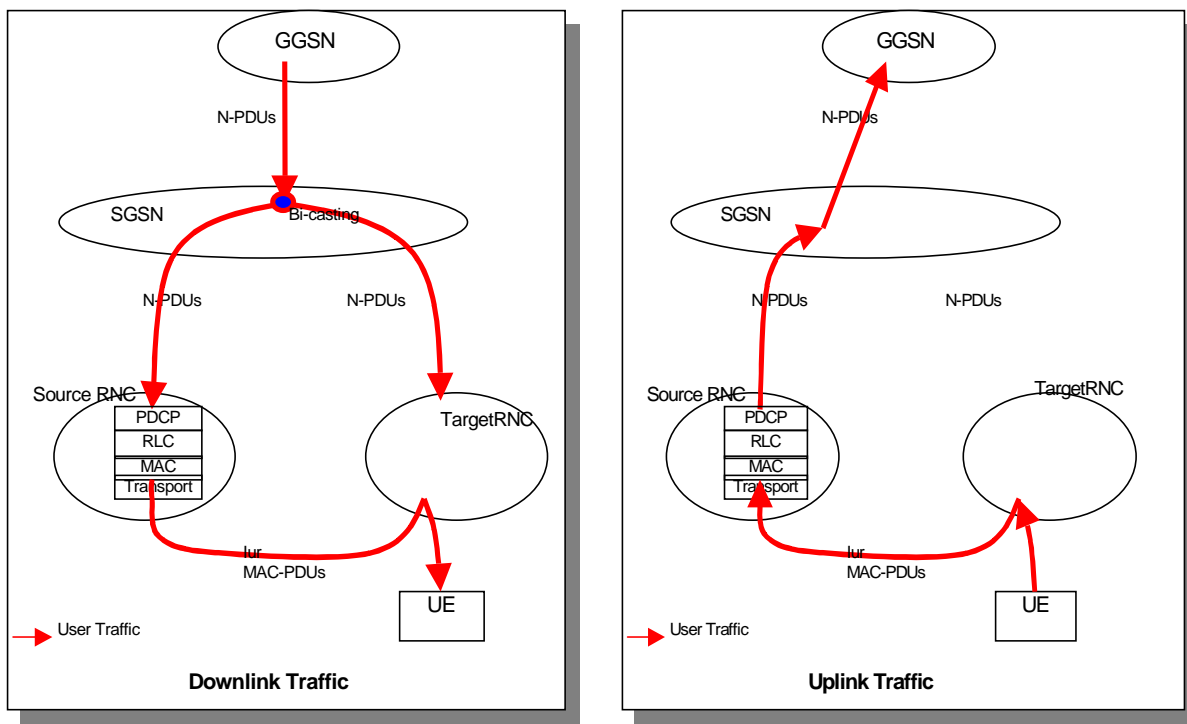

Figure 21: User Plane - Bi-casting of DL flow with only one SGSN (SRNS Relocation)

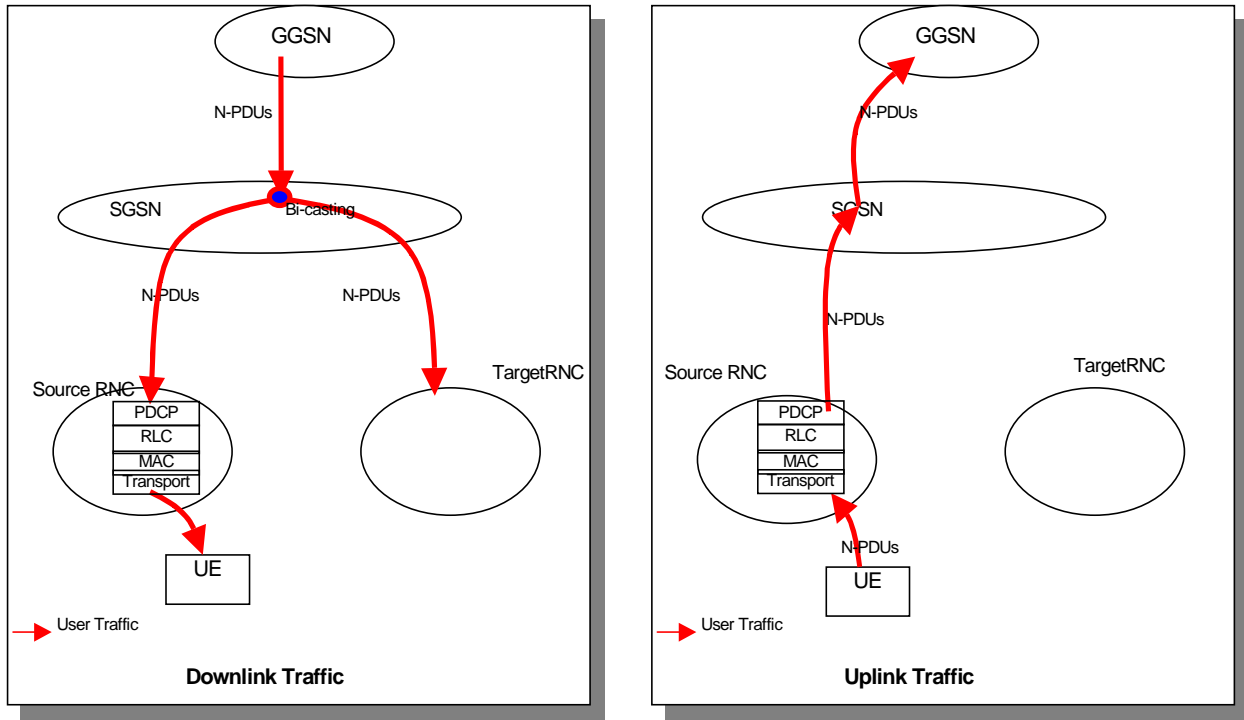

Figure 22: User Plane - Bi-casting of DL flow with only one SGSN (Hard Handover)

6.2.3.2 Bi-casting of DL flow and switching of UL flow

In this phase, DL traffic is bi-casted from the SGSN to the target RNC (as well as to the source RNC). Also at this point in both the hard handover and SRNS relocation cases, the UE sends UL traffic to the target RNC and UL traffic needs to be switched to the SGSN and using the new route.

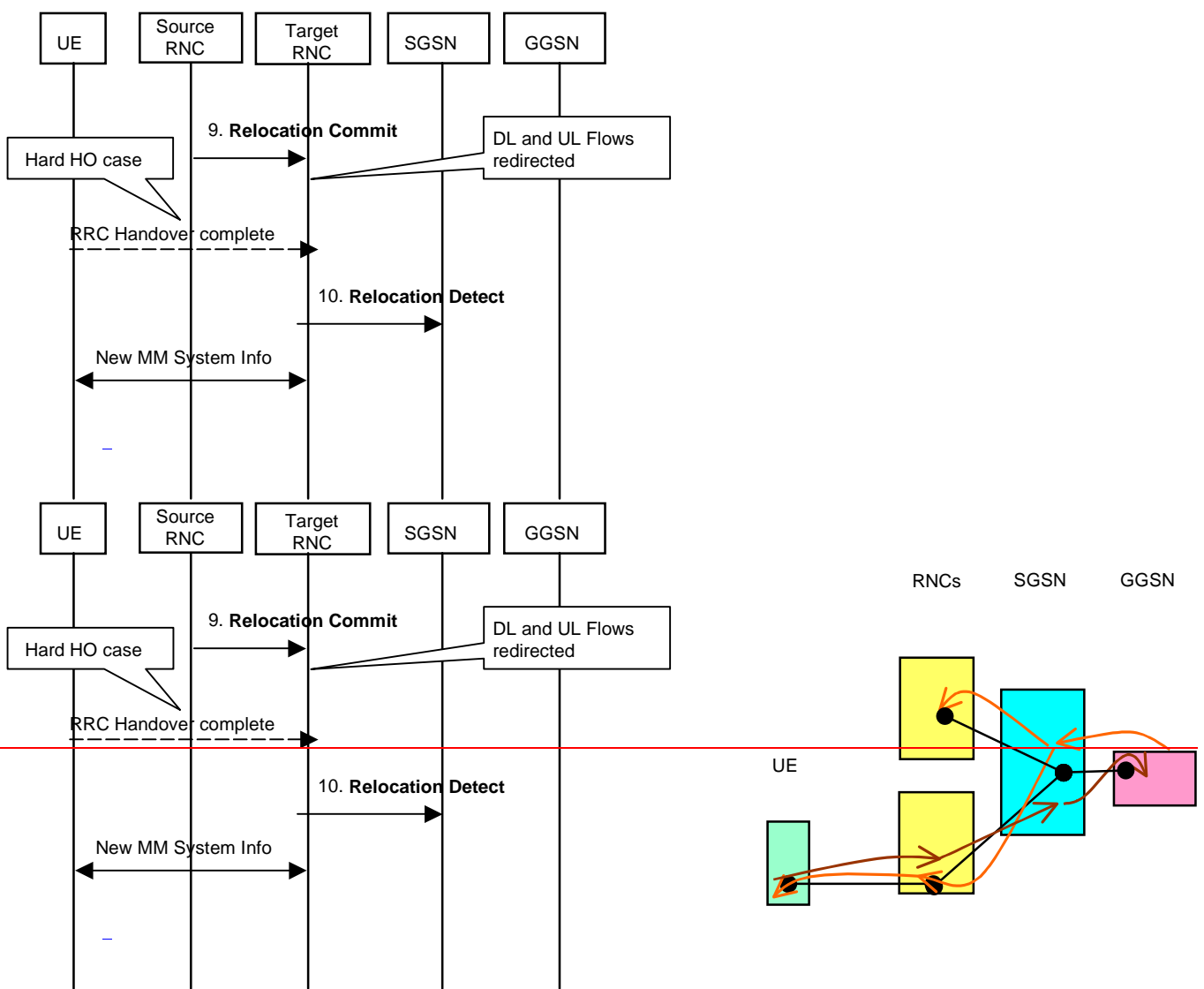

Figure 23: Control Plane - Bi-casting of DL flow and switching of UL flow phase with only one SGSN

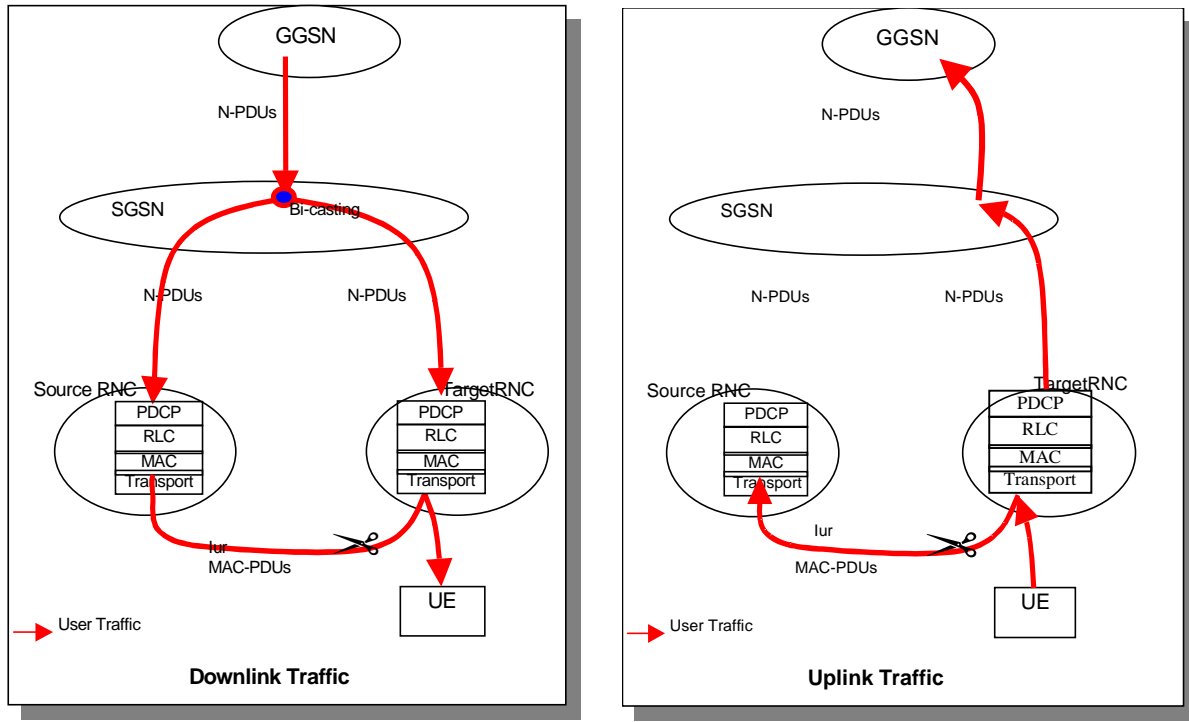

Figure 24: Moving the serving RNC to target RNC with only one SGSN (SRNS Relocation)

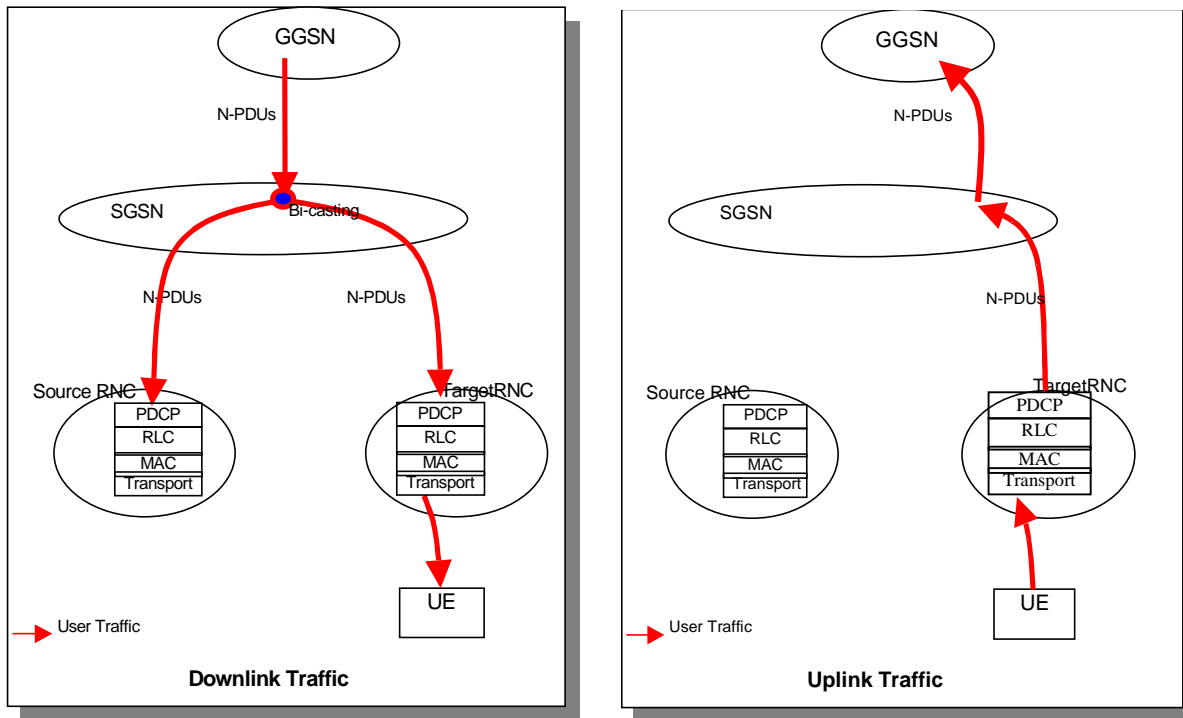

Figure 25: Moving the serving RNC to target RNC with only one SGSN (Hard Handover)

6.2.3.3 Completion

This is the completion of the signalling. Also, the SGSN is instructed to stop bi-casting downlink N-PDUs. At this stage, the relocation has effectively already been completed.

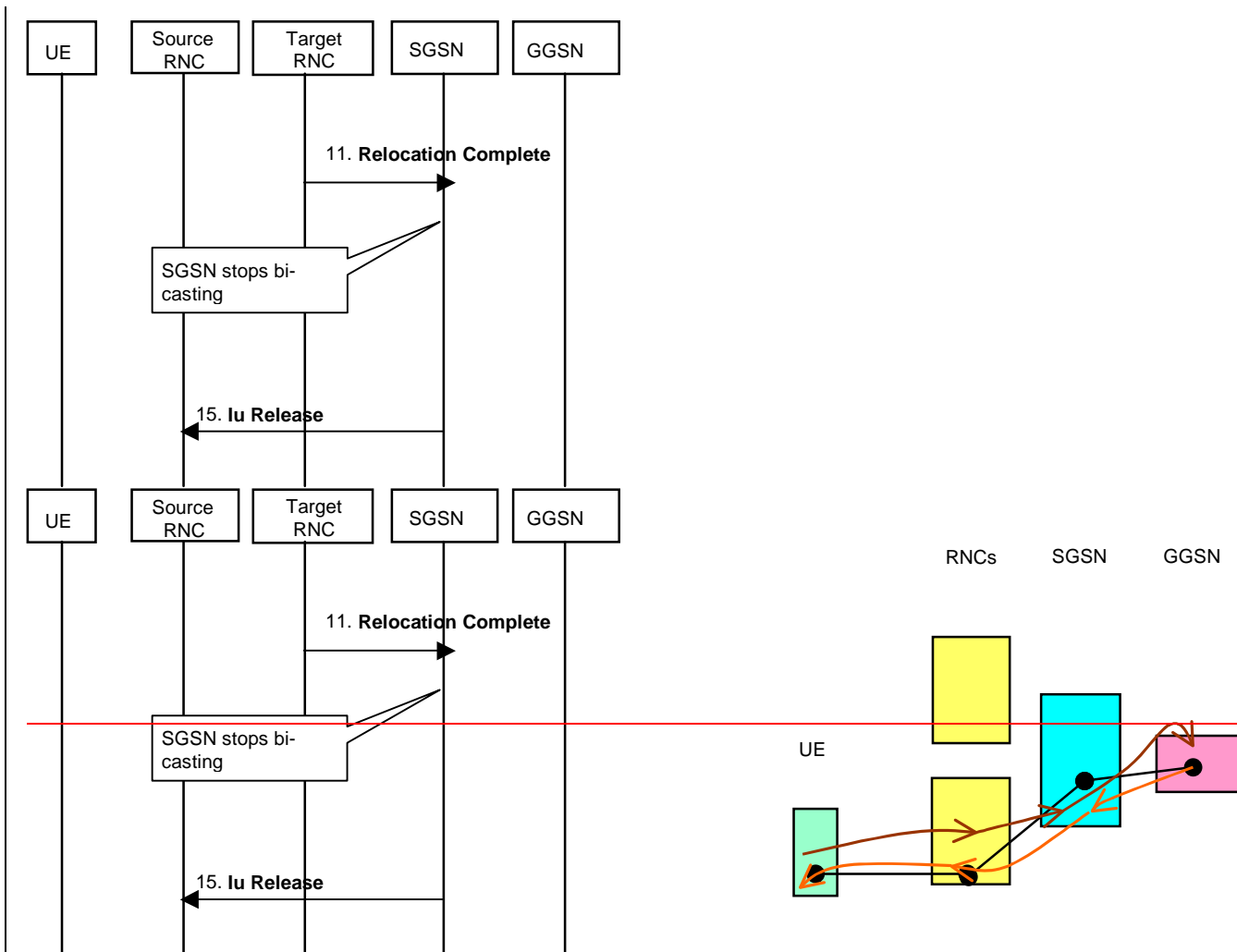

Figure 26: Control Plane – Completion phase with only one SGSN

Handling of abnormal conditions in the Completion phase:

If the RELOCATION DETECT message is not received by the SGSN before reception of RELOCATION COMPLETE message, the SGSN shall handle the RELOCATION COMPLETE message normally.

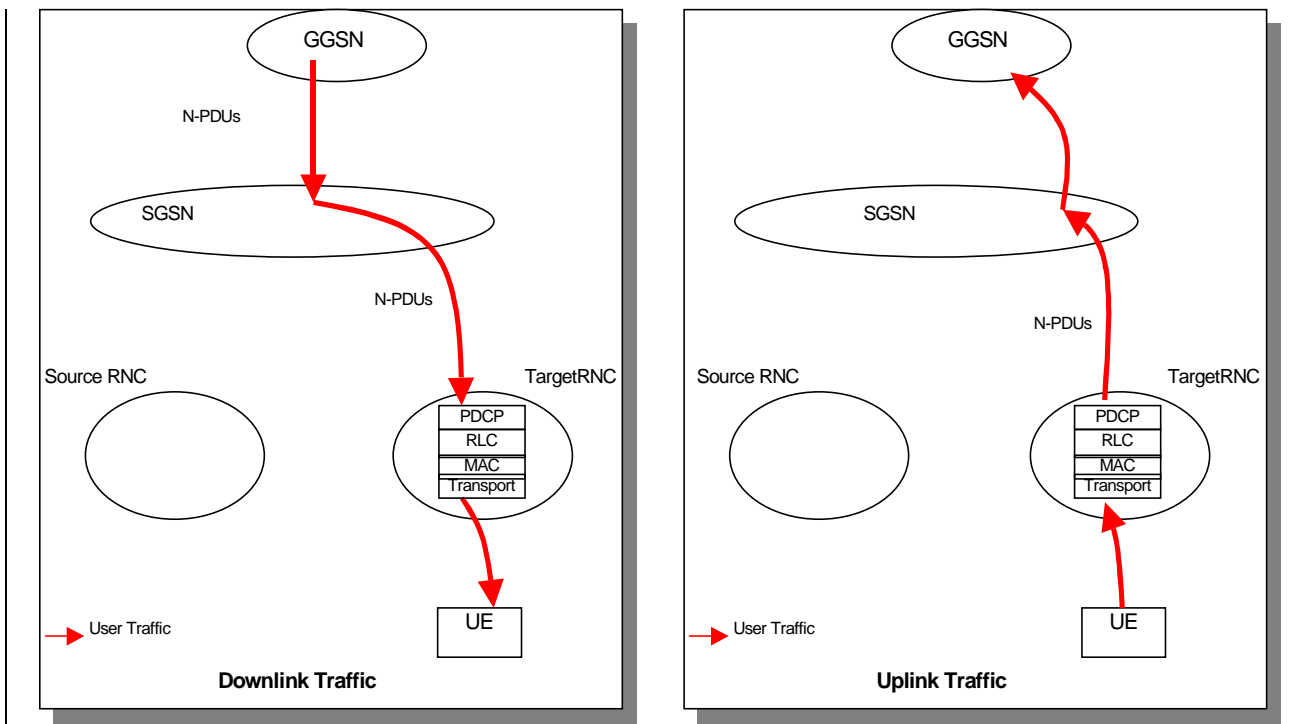

Figure 27: User Plane – Completion phase with only one SGSN

6.2.4 Specifications Impact

6.2.4.1 Impacts on RAN3 specifications

Solution 2 does not require any new procedures or messages to be introduced to any RAN 3 specification.
If a clear indication is added to the RAB parameters that a RAB is to be treated in a “lossless” or “other” way, then a new value for that Information Element is needed to indicate “seamless” to the source RNC. This is pending resolution of the R99 issue pointed out in LS R3-002874.
The currently identified impacts to R3 specifications relate to specifying the behaviour of the source and target RNC. This is specified in 25.413.

6.2.4.2 Impacts on other groups’ specifications

The impacts to other groups’ specifications relate to inclusion of bi-casting from GGSN to the Gn interface specification and corresponding stage 2 specifications.
 Procedures to initialise and terminate the GGSN bicasting from SGSN including error cases needs to be defined by TSG CN WG4.

29.060 example changes:

The Bi-cast request indicates to the GGSN the requirement for real-time relocation.

Information Elements in an SGSN-Initiated Update PDP Context Request

Information element	Presence requirement	Reference
Recovery	Optional	7.7.11
Tunnel Endpoint Identifier for Data (I)	Mandatory	7.7.13
Tunnel Endpoint Identifier Control Plane	Conditional	7.7.14
NSAPI	Mandatory	7.7.17
Trace Reference	Optional	7.7.24
Trace Type	Optional	7.7.25
SGSN Address for Control Plane	Mandatory	GSN Address 7.7.32
SGSN Address for User Traffic	Mandatory	GSN Address 7.7.32
Quality of Service Profile	Mandatory	7.7.34
TFT	Optional	7.7.36
Trigger Id	Optional	7.7.41
OMC Identity	Optional	7.7.42
Bi-cast request	Conditional	New reference
Private Extension	Optional	7.7.44

Bi-casting Request Information Element

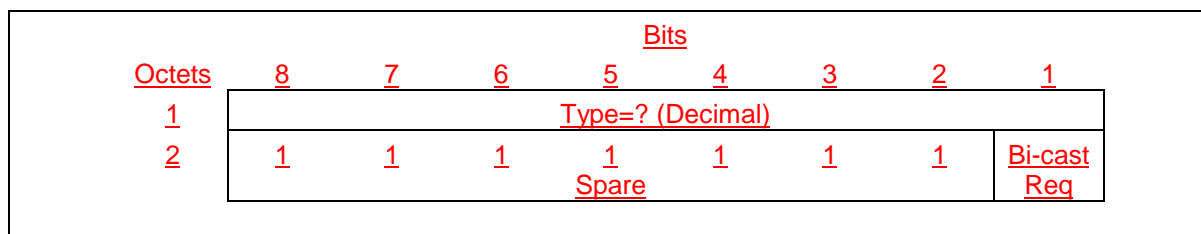

Bi-casting Request Values

Bi-casting request	Value (Decimal)
Stop	0
Start	1

New cause value

response	rej	Bi-casting not supported	New
		Bi-casting not possible	New

When creating a new PDP context, an indication is needed to indicate that the RAB is to be treated in a seamless way.

GTP-U changes to flag packets as bi-casted are needed. The spare bit (bit 4) of octet 1 in the GTP header (defined in Figure 2 of section 6 of 29.060) could be utilized to indicate if a packet was bi-casted.

Stage 2 specification TS 23.060 has to be aligned with the selected solution for RT PS domain Relocation of SRNS.

6.2.5 Interaction with other systems

This section is intended to explain how this solution will work with other systems such as GERAN, UTRAN-R99, GSM and GPRS. This is subject to information availability for these other systems.

The Core Network bi-casting solution will work with a GERAN connected via the Iu-PS in exactly the same way as with a UTRAN connected via the Iu-PS. Therefore all the description above is applicable to GERAN, with the RNC being replaced by a BSS (can contain BSCs or not). There is no other functionality required at the BSS other than supporting the messaging for the Iu-PS (release 4).

If a release 4 Core Network is connected to a GPRS BSS, since there is no Iu-PS, no relocation can be provided.

If a release 4 Core Network is connected to a R99 UTRAN, then for lossless RABs, the Core Network can request data forwarding. For seamless RABs, the Core Network can not request data forwarding, and wont do bi-casting either since R99 UTRAN does not support real-time services.

The SGSN will request handover treatment from the RNC as follows:

	<u>Rel 99 CN</u>	<u>Rel 4 CN</u>
<u>Rel 99 UTRAN</u>	<u>Will only request lossless or other</u>	<u>Will request lossless, other or seamless (which will fail)</u>
<u>Rel 4 UTRAN</u>	<u>Will only request lossless or other</u>	<u>Will request lossless, seamless or other – can all be supported by UTRAN</u>

If the handover is between UMTS Rel 4 and UMTS R99, we will have the following:

<u>From</u>	<u>To</u>	<u>Rel 99 UTRAN + Rel 99 CN</u>	<u>Rel 99 UTRAN + Rel 4 CN</u>	<u>Rel 4 UTRAN + Rel 99 CN</u>	<u>Rel 4 UTRAN + Rel 4 CN</u>
<u>Rel 99 UTRAN + Rel 99 CN</u>		<u>Lossless or other</u>	<u>Lossless or other</u>	<u>Lossless or other</u>	<u>Lossless or other</u>
<u>Rel 99 UTRAN + Rel 4 CN</u>		<u>Lossless or other</u>	<u>Lossless or other</u>	<u>Lossless or other</u>	<u>Lossless or other</u>
<u>Rel 4 UTRAN + Rel 99 CN</u>		<u>Lossless or other</u>	<u>Lossless or other</u>	<u>Lossless or other</u>	<u>Lossless or other</u>
<u>Rel 4 UTRAN + Rel 4 CN</u>		<u>Lossless or other</u>	<u>Lossless or other</u>	<u>Lossless or other</u>	<u>Lossless, seamless or other</u>

If the handover is inter-system from UMTS Rel 4 to GPRS, then the same principle of Core Network bi-casting can be applied. This means real-time support could be provided for that type of handover, assuming that the SGSN in the GPRS network can use the latest version of GTP-C. There is no requirement for the GPRS SGSN to support an Iu interface for real-time support.

If the handover is inter-system from GPRS to UMTS Rel 4, then no relocation is triggered.

6.2.6 Summary: solution 2

In the Core Network bi-casting solution, handling of the real time data is done at the GGSN. Real time support requires that the GGSN is able to bi-cast the DL traffic to the target RNC. In the case of relocation involving only one SGSN, the SGSN may perform the bi-casting without involving the GGSN.

~~In a hard handover case, there is a transmission break during the time that the UE performs the hard handover. This affects UL and DL, and is the only break in the UL transmission.~~

~~In relocation there might be a break in the UL direction when the UL connection is switched to the new Iu.~~

In any handover or relocation case, for DL there is one possible situation when frame gap or overlapping may happen. This occurs when the target RNC receives bi-casted DL traffic from the new GTP tunnel as well as the bi-casted traffic from the Iur, and switches from the latter to the former. This coincides with radio hard handover.

To support handovers for real time services from the PS domain with the Core Network bi-casting solution, procedural changes are required at the SGSN, GGSN, and RNC.

6.2.7 Open issues

~~What is the delay of initiating GGSN bi-casting from all active GGSNs for a user?~~

~~How the GGSN based RT mechanism and RNC-based NRT mechanism work together. Especially how the failure and error case co-ordination is handled?~~

7 Open items for all solutions

How the SGSN and the source RNC know which GTP-tunnels and RABs should be subject for real-time handling and which for Source RNC Data Forwarding (R99) i.e. NRT RABs?

Real time PDCP numbers are a RAN2 issue that has not been resolved yet. The questions to be solved with R2 include whether the RAB contexts (i.e. the sequence numbers) need to be between RNCs or not, and whether the header compression/stripping solution to be selected allows that transmission to UE continues via the Iur (i.e. effectively making the context in RELOCATION COMMIT message outdated).

According to the UMTS release 99 specifications, PDCP sequence numbers are exchanged with the UE as follows:

- UL: The target RNC can determine the UL sequence number which according to the header decompression information should be the next PDCP to be received from the UE. To do this, the RNC uses the PDU causing the RLC to re-establish.. This UL sequence number given by the RNC might be a few sequence numbers lower than the assumption of UE, since it has still maybe sent a few PDUs via source RNC after commit. UE should roll back the PDCP header compression and thus base the next compressed header of the next real-time PDU to the header information of the UL PDU considered as the last received by the target RNC (the indicated one - 1).
- DL: Similarly UE indicates in the PDU acknowledging the RLC re-establishment the DL Sequence number which PDU according to the DL header decompression information in the UE should next be received by UE. This is not generally the first forwarded but one of the first ones. Target RNC selects appropriate forwarded PDU and bases its header compression to the header of the 'indicated DL PDCP PDU-1'.

8 Comparison of the solutions

9 Agreements

This section is intended to list any agreements that have been reached in RAN3 on this work item.

10 Project Plan

10.1 Schedule

Date	Meeting	Scope	[expected] Input	[expected]Output

10.2 Work Task Status

	Planned Date	Milestone	Status
1.			
2.			

11 History

Document history		
V0.0.0	2000-07	Scope and document outline
V0.0.1	2000-07	First proposal for chapters 4, 5, 6 and 7
V0.1.0	2000-09	Changes agreed at RAN3#15.
V0.1.1	2000-10	Rapporteur's proposal to RAN3#16.
V0.2.1	2000-10	Changes agreed at RAN3#16.
V0.2.2	2000-11	Rapporteur's proposal to RAN3#17.
<u>V0.3.0</u>	<u>2000-11</u>	<u>Proposed changes after RAN3#17, sent for e-mail comments.</u>
Rapporteur for 3GPP RAN TR 25.936 is:		
Claire Mousset, Nortel Networks Tel: +44 1628 434285 Fax: +44 1628 434034 cmousset@nortelnetworks.com		
This document is written in Microsoft Word version 97 SR-2.		