

**TSG-RAN Meeting #8
Düsseldorf, Germany, 21 – 23 June 2000**

RP-000212

Title: Agreed CRs to TS 25.142

Source: TSG-RAN WG4

Agenda item: 5.4.3

Doc-1st-	Spec	CR	Re	Phas	Subject	Cat	Versio	Version-
RP-000212	25.142	013		R99	UL Reference Measurement Channels	F	3.1.0	3.2.0
RP-000212	25.142	014		R99	Regional requirements in TS 25.142	F	3.1.0	3.2.0
RP-000212	25.142	015		R99	Conformance test description for receiver dynamic range.	F	3.1.0	3.2.0
RP-000212	25.142	016		R99	Correction of the interfering power level for performance	F	3.1.0	3.2.0
RP-000212	25.142	017		R99	Definitions of maximum output power and rated output power	F	3.1.0	3.2.0
RP-000212	25.142	018		R99	Correction of blocking requirements	F	3.1.0	3.2.0
RP-000212	25.142	020		R99	Conformance test description for modulation accuracy	F	3.1.0	3.2.0
RP-000212	25.142	021		R99	Modification to the handling of BS TDD Measurement Uncertainty	F	3.1.0	3.2.0
RP-000212	25.142	022		R99	Clarification of the specification on Peak Code Domain Error	F	3.1.0	3.2.0
RP-000212	25.142	023		R99	Relationship between RF generation and chip clock	F	3.1.0	3.2.0
RP-000212	25.142	024		R99	Correction on Receiver tests, terminating RX port	F	3.1.0	3.2.0
RP-000212	25.142	025		R99	Revision of Annex C: Global in-channel Tx test	F	3.1.0	3.2.0
RP-000212	25.142	026		R99	Conformance test description for spectrum emission mask	F	3.1.0	3.2.0
RP-000212	25.142	027		R99	Test connection definition	F	3.1.0	3.2.0

CHANGE REQUEST

Please see embedded help file at the bottom of this page for instructions on how to fill in this form correctly.

25.142 CR 013

Current Version: **3.1.0**

GSM (AA.BB) or 3G (AA.BBB) specification number ↑

↑ CR number as allocated by MCC support team

For submission to: **RAN #8**
list expected approval meeting # here ↑

for approval
for information

strategic
non-strategic (for SMG use only)

Form: CR cover sheet, version 2 for 3GPP and SMG The latest version of this form is available from: <ftp://ftp.3gpp.org/Information/CR-Form-v2.doc>

Proposed change affects:
(at least one should be marked with an X)

(U)SIM ME UTRAN / Radio Core Network

Source: RAN WG4

Date: 22.5.2000

Subject: UL reference measurement channels

Work item: TS 25.142

Category:

(only one category shall be marked with an X)

F Correction
A Corresponds to a correction in an earlier release
B Addition of feature
C Functional modification of feature
D Editorial modification

Release:

Phase 2
Release 96
Release 97
Release 98
Release 99
Release 00

Reason for change:

Alignment of the UL reference measurement channels with current RAN WG1 and WG2 specifications

Clauses affected: Annex A

Other specs affected:

Other 3G core specifications → List of CRs:
Other GSM core specifications → List of CRs:
MS test specifications → List of CRs:
BSS test specifications → List of CRs:
O&M specifications → List of CRs:

Other comments:

Annex A (normative): Measurement Channels

A.1 General

A.2 Reference measurement channel

A.2.1 UL reference measurement channel (12.2 kbps)

Parameter	
Information data rate	12.2 kbps
RU's allocated	2 RU
Midamble	512 chips
Interleaving	20 ms
Power control	2 Bit/user
TFCI	16 Bit/user
Inband signalling DCCH	2 kbps
Puncturing level at Code rate 1/3 : DCH / DCCH	5% / 0%

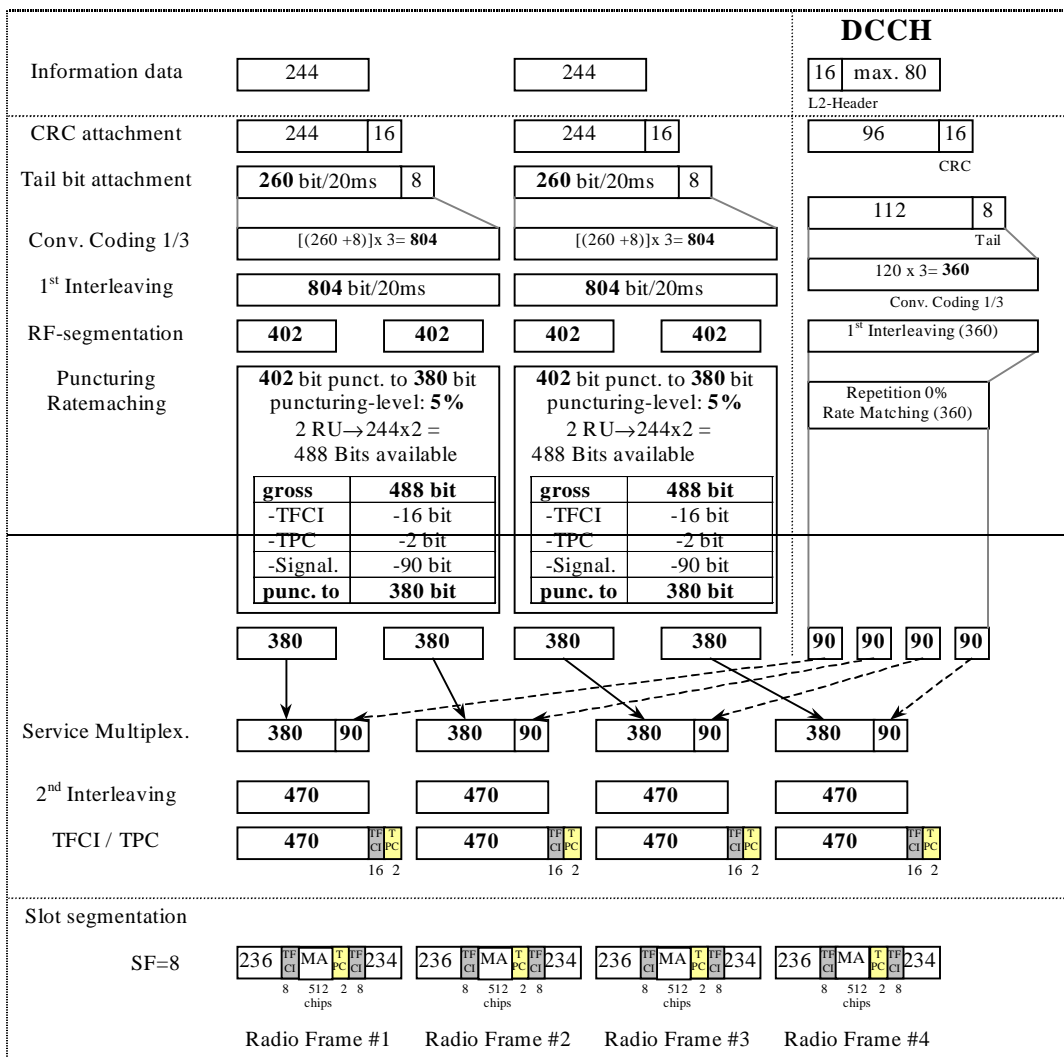

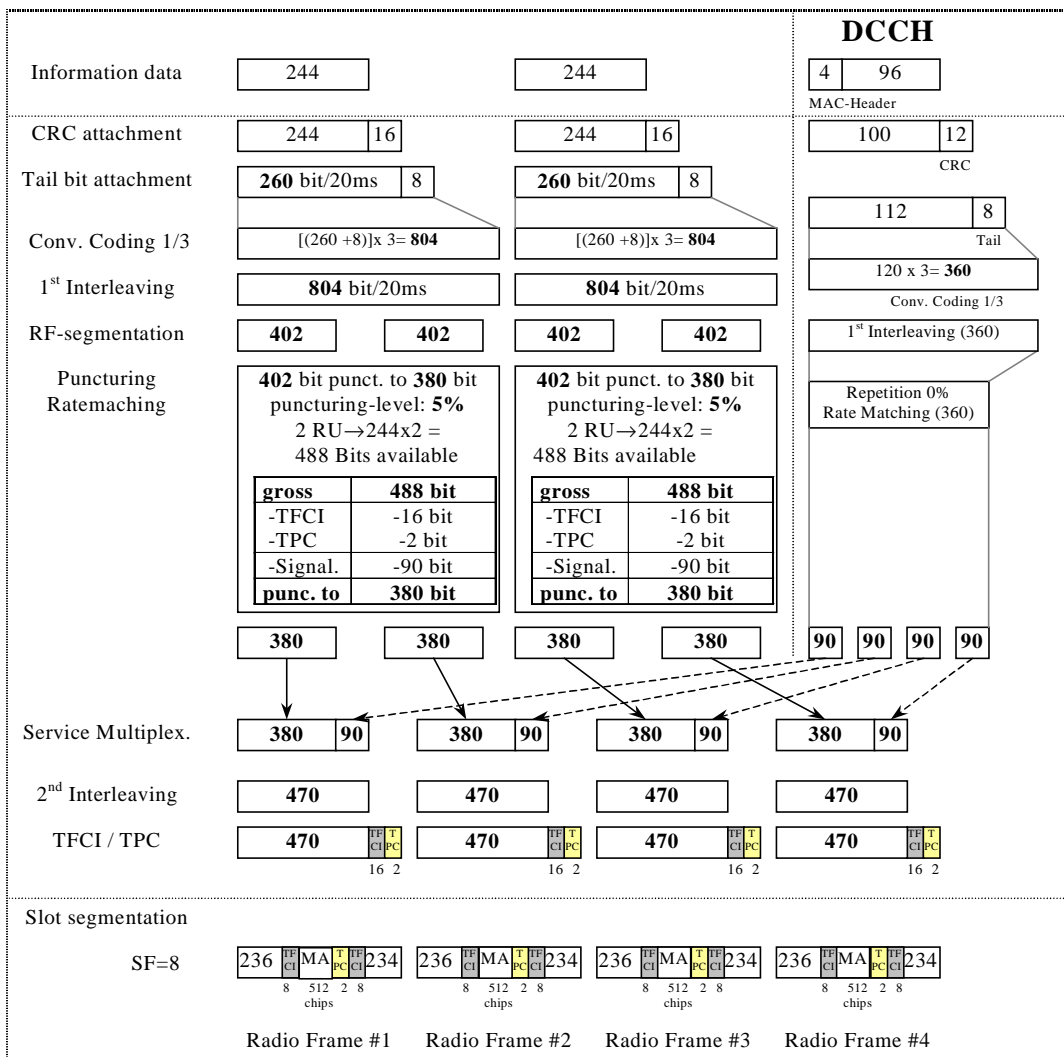

A.2.2 UL reference measurement channel (64 kbps)

Parameter	
Information data rate	64 kbps
RU's allocated	1 SF4 + 1 SF16 = 5RU
Midamble	512 chips
Interleaving	20 ms
Power control	2 Bit/user
TFCI	16 Bit/user
Inband signalling DCCH	2 kbps
Puncturing level at Code rate : 1/3 DCH / 1/2 DCCH	41.2% / 10%

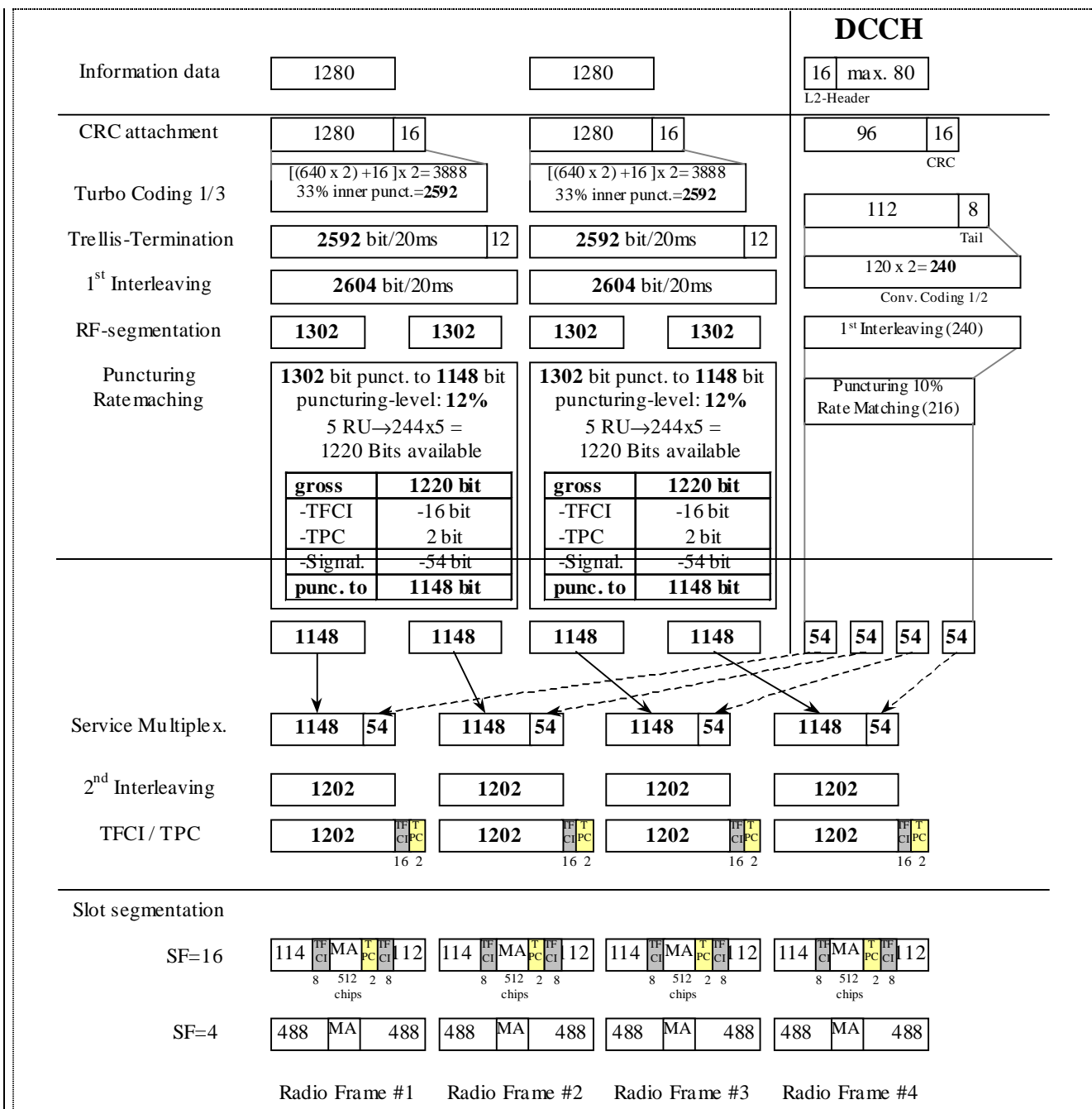

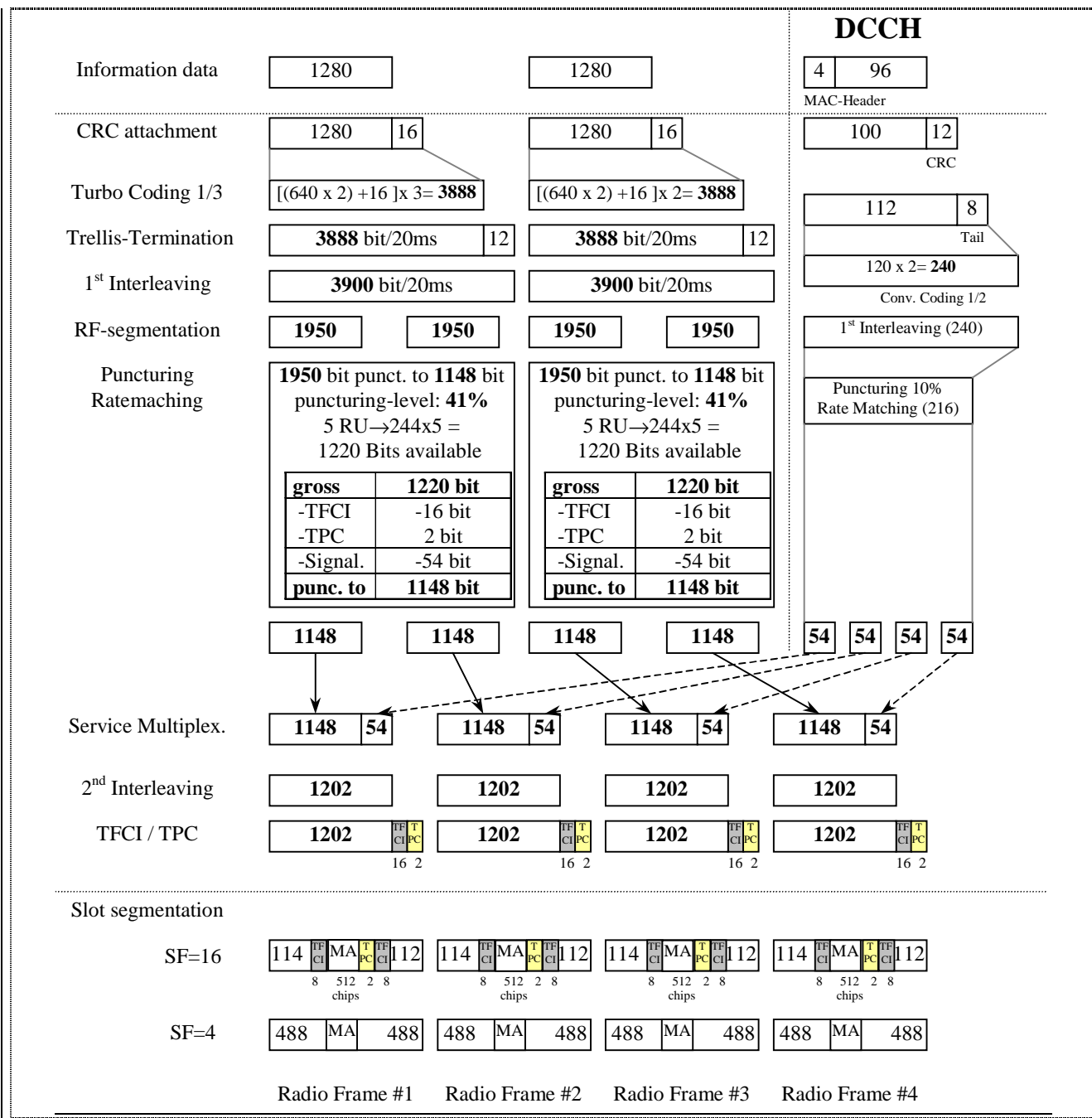

A.2.3 UL reference measurement channel (144 kbps)

Parameter	
Information data rate	144 kbps
RU's allocated	1 SF2 + 1 SF16 = 9RU
Midamble	256 chips
Interleaving	20 ms
Power control	2 Bit/user
TFCI	16 Bit/user
Inband signalling DCCH	2 kbps
Puncturing level at Code rate : 1/3 DCH / 1/2 DCCH	44.4% / 16.6%

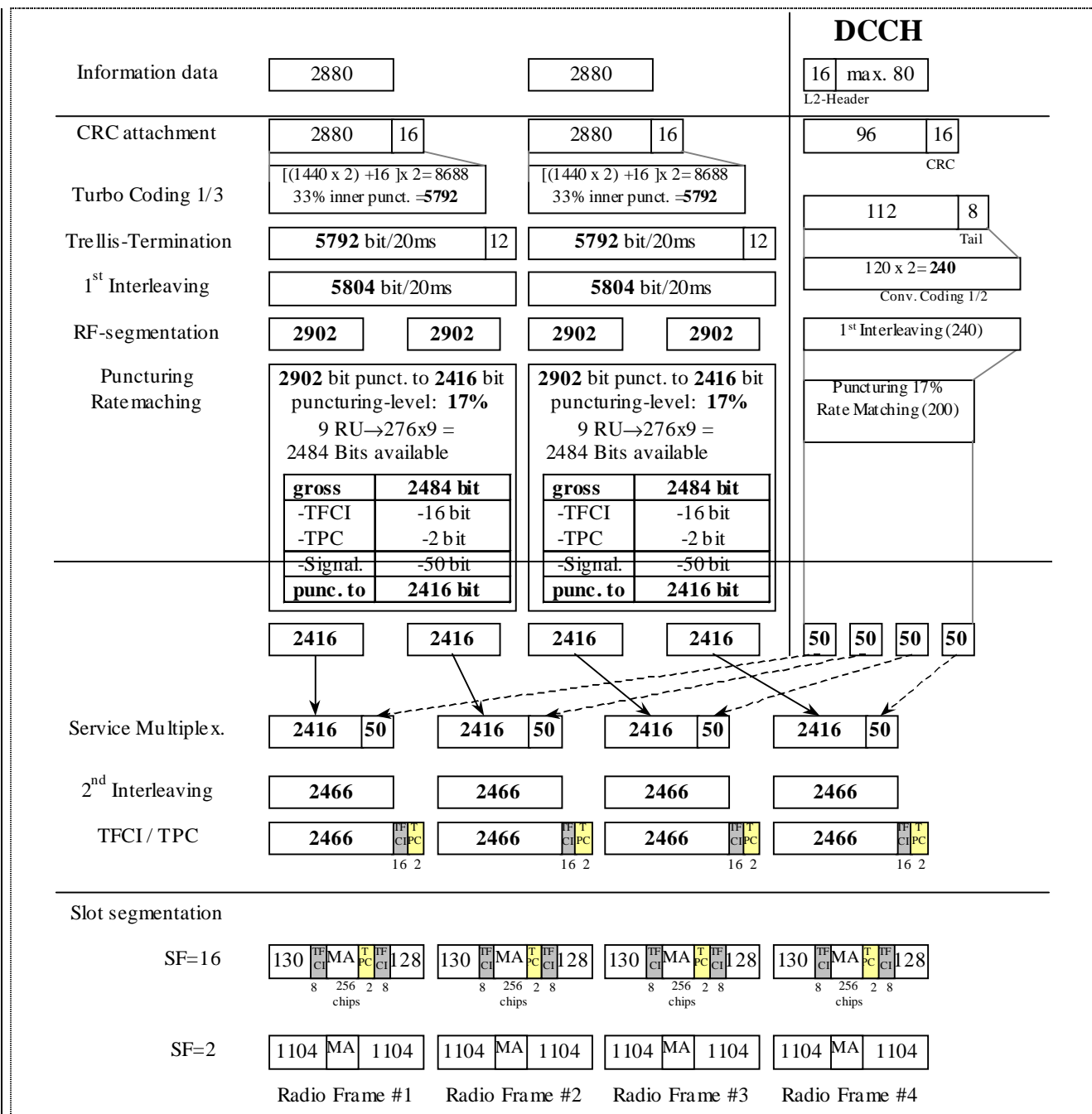

DCCH

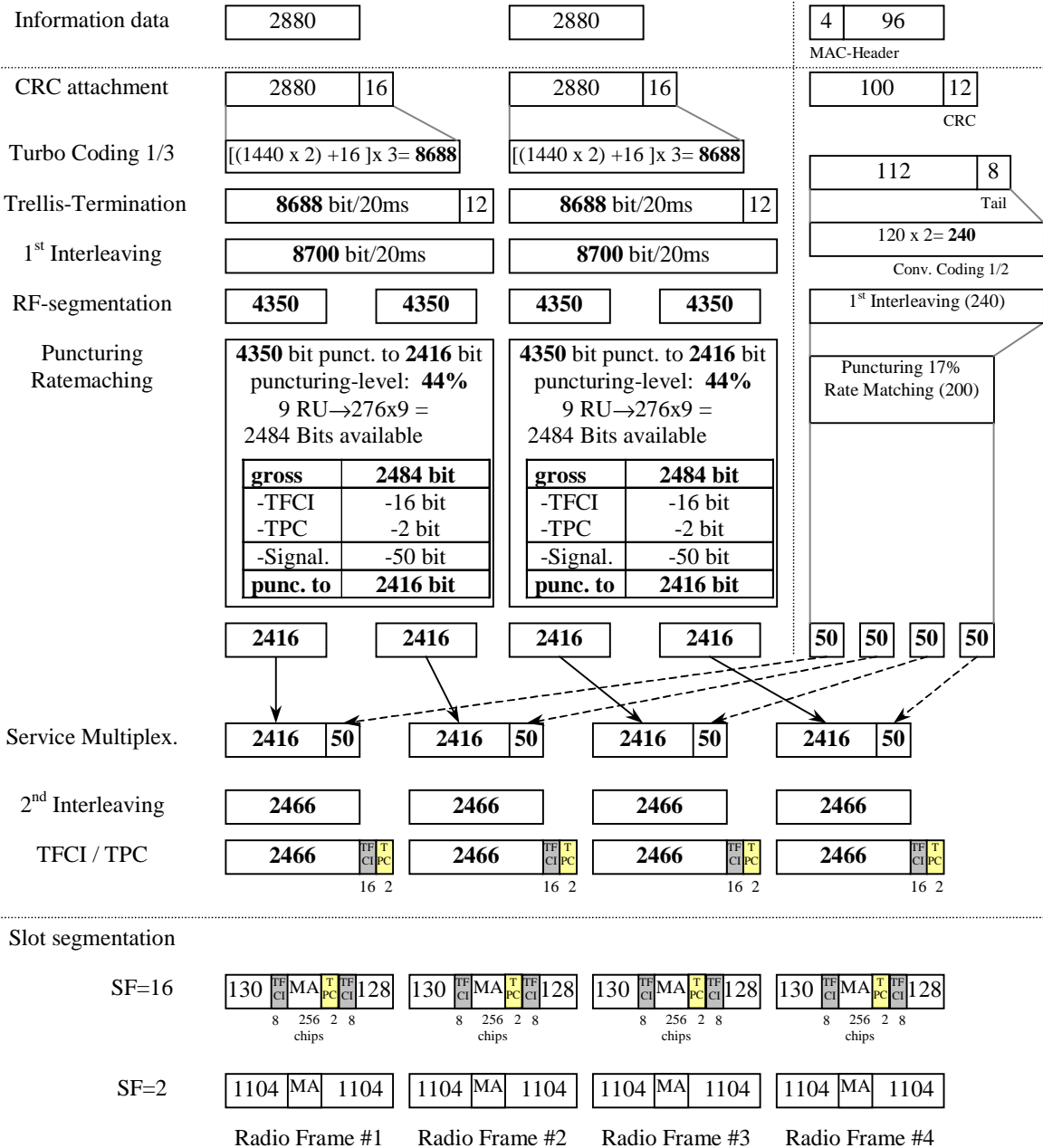

A.2.4 UL reference measurement channel (384 kbps)

Parameter	
Information data rate	384 kbps
RU's allocated	$8 \cdot 3TS = 24RU$
Midamble	256 chips
Interleaving	20 ms
Power control	2 Bit/user
TFCI	16 Bit/user
Inband signalling DCCH	2 kbps
Puncturing level at Code rate : 1/3 DCH / 1/2 DCCH	43.4% / 15.3%

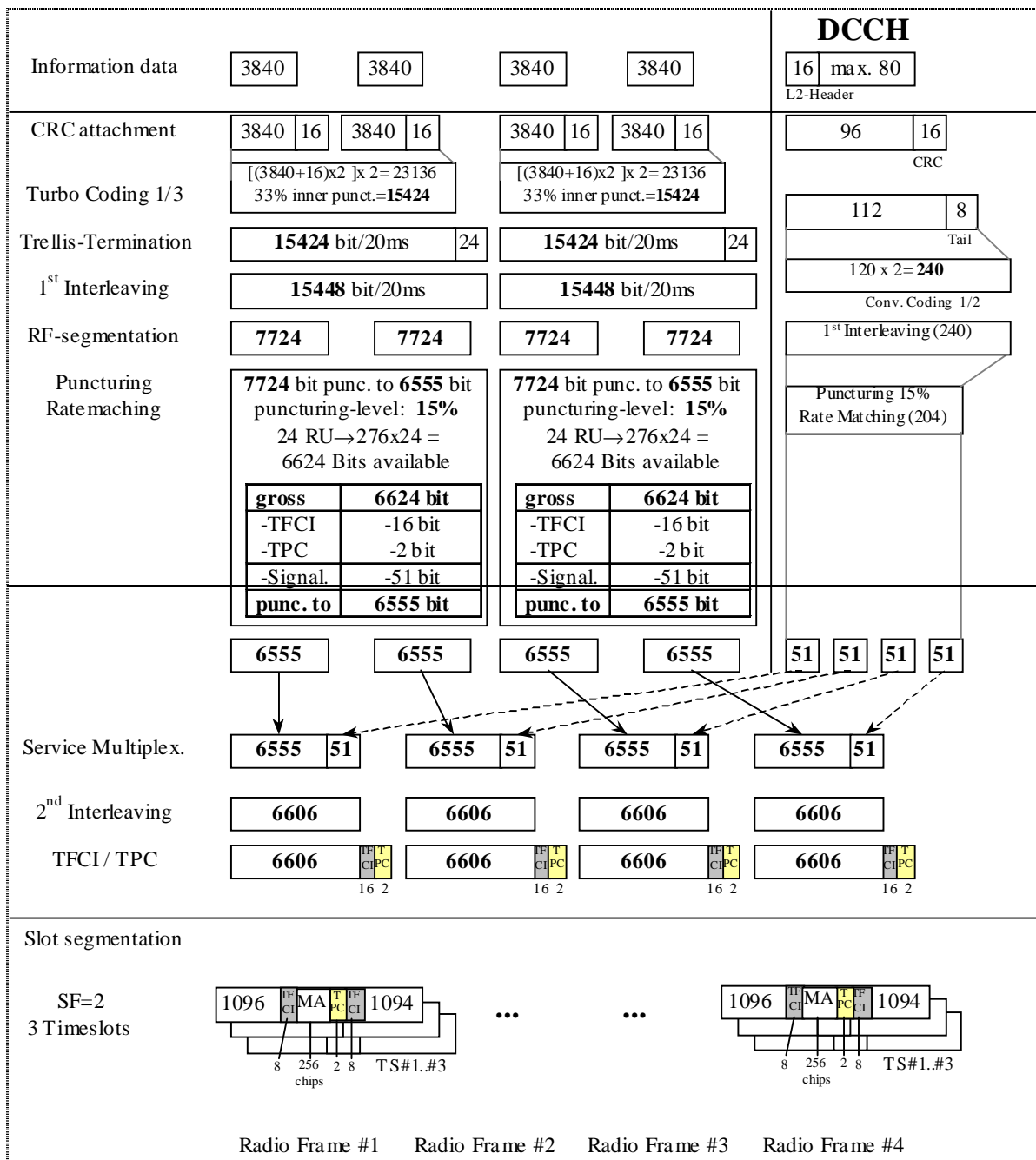

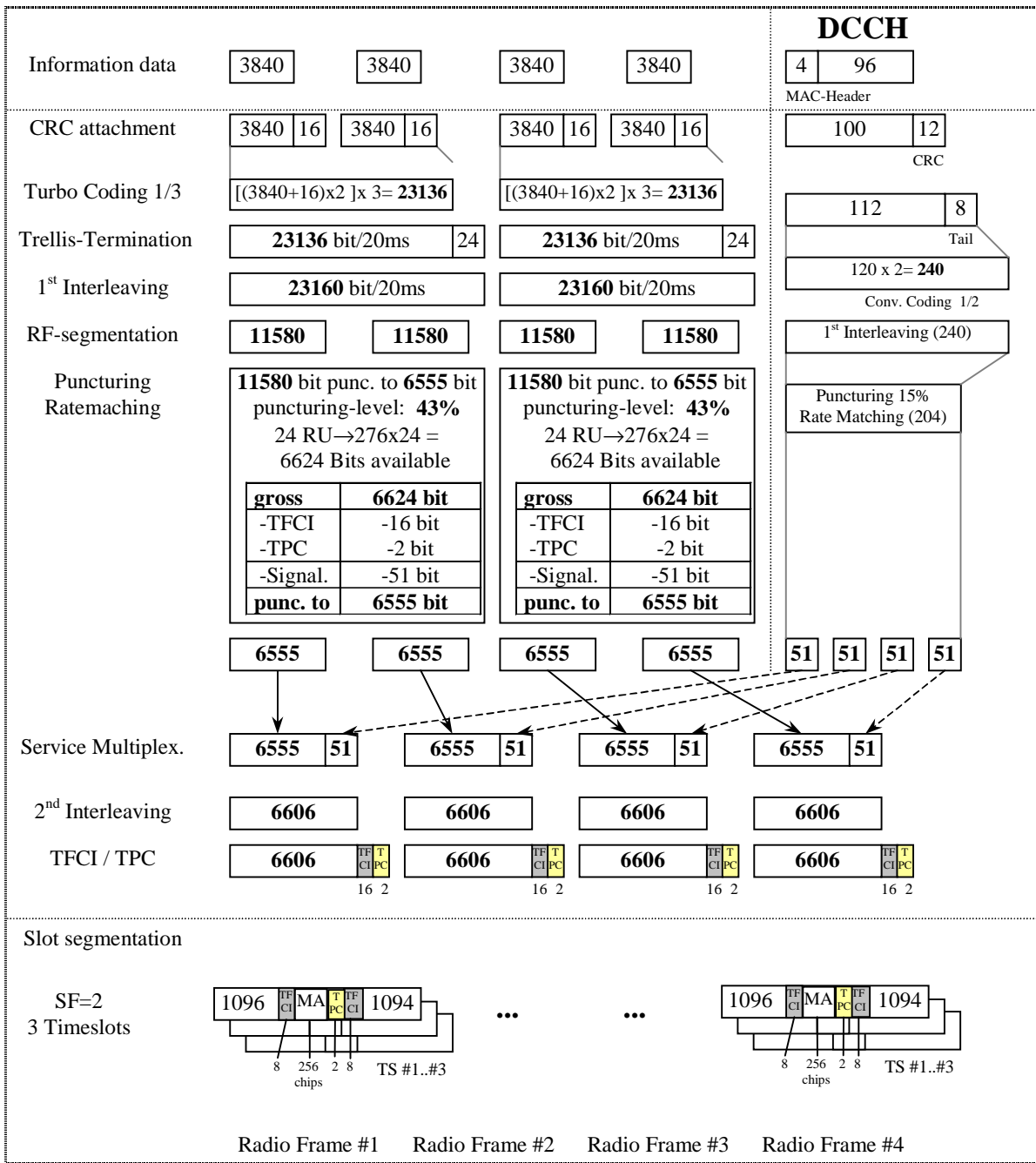

CHANGE REQUEST

Please see embedded help file at the bottom of this page for instructions on how to fill in this form correctly.

25.142 CR 014

Current Version: **3.1.0**

GSM (AA.BB) or 3G (AA.BBB) specification number ↑

↑ CR number as allocated by MCC support team

For submission to: **RAN #8**
list expected approval meeting # here ↑

for approval
for information

strategic
non-strategic (for SMG use only)

Form: CR cover sheet, version 2 for 3GPP and SMG The latest version of this form is available from: <ftp://ftp.3gpp.org/Information/CR-Form-v2.doc>

Proposed change affects:

(at least one should be marked with an X)

(U)SIM ME UTRAN / Radio Core Network

Source:

RAN WG4

Date:

11/04/00

Subject:

Regional requirements in TS 25.142

Work item:

Category:

(only one category shall be marked with an X)

F Correction
A Corresponds to a correction in an earlier release
B Addition of feature
C Functional modification of feature
D Editorial modification

Release:

Phase 2
Release 96
Release 97
Release 98
Release 99
Release 00

Reason for change:

Several requirements in TS 25.142 will be applied regionally only, since they depend on regional regulatory requirements or on co-existence with systems that are deployed regionally. The proposed text for clause 5 "General test conditions and declarations" clarifies this.
A regional requirement is also added for subclause 6.2.

Clauses affected:

5, 5.14, 6.2.2

Other specs affected:

Other 3G core specifications → List of CRs:
Other GSM core specifications → List of CRs:
MS test specifications → List of CRs:
BSS test specifications → List of CRs:
O&M specifications → List of CRs:

Other comments:

5 General test conditions and declarations

The requirements of this clause apply to all tests in this TS, when applicable.

The general conditions during the tests should be according to the relevant parts of ETR 027 [2] (methods of measurement for mobile radio equipment) with the exceptions and additions defined in the individual tests.

Many of the tests in this TS measure a parameter relative to a value which is not fully specified in the UTRA specifications. For these tests, the conformance requirement is determined relative to a nominal value specified by the manufacturer.

Certain functions of a BS are optional in the UTRA specifications. [Some requirements for the BS may be regional as listed in subclause 5.14.](#)

When specified in a test, the manufacturer shall declare the nominal value of a parameter, or whether an option is supported.

5.14 Regional requirements

Some requirements in TS 25.142 may only apply in certain regions. Table 5.14.1 lists all requirements that may be applied differently in different regions.

Table 5.14.1: List of regional requirements

<u>Subclause number</u>	<u>Requirement</u>	<u>Comments</u>
4.2	<u>Frequency bands</u>	<u>Some bands may be applied regionally.</u>
6.2.2	<u>Maximum output power</u>	<u>In certain regions, the minimum requirement for normal conditions may apply also for some conditions outside the ranges defined for the Normal test environment in subclause 5.8.1</u>
6.6.2.1.	<u>Spectrum emission mask</u>	<u>The mask specified may be mandatory in certain regions. In other regions this mask may not be applied.</u>
6.6.3.2.1.1	<u>Spurious emissions (Category A)</u>	<u>These requirements shall be met in cases where Category A limits for spurious emissions, as defined in ITU-R Recommendation SM.329-7 [1], are applied.</u>
6.6.3.2.1.2	<u>Spurious emissions (Category B)</u>	<u>These requirements shall be met in cases where Category B limits for spurious emissions, as defined in ITU-R Recommendation SM.329-7 [1], are applied.</u>
6.6.3.2.2.1	<u>Co-existence with GSM900 – Operation in the same geographic area</u>	<u>This requirement may be applied for the protection of GSM 900 MS in geographic areas in which both GSM 900 and UTRA are deployed.</u>
6.6.3.2.2.2	<u>Co-existence with GSM900 – Co-located base stations</u>	<u>This requirement may be applied for the protection of GSM 900 BTS receivers when GSM 900 BTS and UTRA BS are co-located.</u>
6.6.3.2.3.1	<u>Co-existence with DCS1800 – Operation in the same geographic area</u>	<u>This requirement may be applied for the protection of DCS 1800 MS in geographic areas in which both DCS 1800 and UTRA are deployed.</u>
6.6.3.2.3.2	<u>Co-existence with DCS1800 – Co-located base stations</u>	<u>This requirement may be applied for the protection of DCS 1800 BTS receivers when DCS 1800 BTS and UTRA BS are co-located.</u>
6.6.3.2.4.1	<u>Co-existence with UTRA FDD – Operation in the same geographic area</u>	<u>This requirement may be applied to geographic areas in which both UTRA-TDD and UTRA-FDD are deployed.</u>
6.6.3.2.4.2	<u>Co-existence with UTRA FDD – Co-located base stations</u>	<u>This requirement may be applied for the protection of UTRA-FDD BS receivers when UTRA-TDD BS and UTRA FDD BS are co-located.</u>
7.5	<u>Blocking characteristic</u>	<u>The requirement is applied according to what frequency bands in subclause 4.2 that are supported by the BS.</u>

6 Transmitter characteristics

6.1 General

Unless otherwise stated, all measurements shall be made at the BS antenna connector.

6.2 Maximum output power

6.2.1 Definition and applicability

Output power, P_{out} , of the base station is the power of one carrier delivered to a load with resistance equal to the nominal load impedance, when averaged (in the sense of thermal power) over the useful part of the burst (time slot).

Maximum output power, P_{max} , of the base station is the output power that the manufacturer has declared to be available at the antenna connector.

The requirements in this subclause shall apply to base stations intended for general-purpose applications.

6.2.2 Conformance requirements

In normal conditions, the base station maximum output power shall remain within +2 dB and -2 dB of the available power declared by the manufacturer.

In extreme conditions, the base station maximum output power shall remain within +2,5 dB and -2,5 dB of the available power declared by the manufacturer.

[In certain regions, the minimum requirement for normal conditions may apply also for some conditions outside the ranges defined for the Normal test environment in subclause 5.8.1.](#)

The reference for this requirement is TS 25.105 subclause 6.2.1.1.

CHANGE REQUEST

Please see embedded help file at the bottom of this page for instructions on how to fill in this form correctly.

25.142 CR 015

Current Version: **3.1.0**

GSM (AA.BB) or 3G (AA.BBB) specification number ↑

↑ CR number as allocated by MCC support team

For submission to: **RAN #8**
list expected approval meeting # here ↑

for approval
for information

strategic
non-strategic (for SMG use only)

Form: CR cover sheet, version 2 for 3GPP and SMG The latest version of this form is available from: <ftp://ftp.3gpp.org/Information/CR-Form-v2.doc>

Proposed change affects:
(at least one should be marked with an X)

(U)SIM ME UTRAN / Radio Core Network

Source:

RAN WG4

Date:

22.5.2000

Subject:

Conformance test description for receiver dynamic range

Work item:

TS 25.142

Category:

F Correction
A Corresponds to a correction in an earlier release
B Addition of feature
C Functional modification of feature
D Editorial modification

(only one category shall be marked with an X)

Release:

Phase 2
Release 96
Release 97
Release 98
Release 99
Release 00

Reason for change:

Alignment of the conformance test description for receiver dynamic range with recent amendments proposed to be incorporated into the core specification TS 25.105

Clauses affected:

7.3

Other specs affected:

Other 3G core specifications → List of CRs:
Other GSM core specifications → List of CRs:
MS test specifications → List of CRs:
BSS test specifications → List of CRs:
O&M specifications → List of CRs:

Other comments:

7.3 Dynamic range

7.3.1 Definition and applicability

~~The receiver dynamic range is the input power range at each BS antenna connector over which the BER does not exceed a specified value.~~

Receiver dynamic range is the receiver ability to handle a rise of interference in the reception frequency channel. The receiver shall fulfil a specified BER requirement for a specified sensitivity degradation of the wanted signal in the presence of an interfering AWGN signal in the same reception frequency channel.

The requirements in this subclause shall apply to base stations intended for general-purpose applications.

7.3.2 Conformance requirements

~~The static BER reference performance as specified in subclause 7.2 shall be met over a receiver input range of 30 dB above the specified reference sensitivity level for the 12,2 kbit/s channel.~~

The BER shall not exceed 0,001 for the parameters specified in table 7.3.2.1.

Table 7.3.2.1: Dynamic Range

Parameter	Level	Unit
Data rate	12,2	kbit/s
Wanted signal	<REFSENS> + 30 dB	dBm
Interfering AWGN signal	-73	dBm/3,84 MHz

The reference for this requirement is TS 25.105 subclause 7.3.

7.3.3 Test purpose

The test purpose is to verify the ability of the BS to receive a prescribed single-code test signal of maximum input power under defined conditions (~~no~~specified interference, no multipath) with a BER not exceeding a specified limit.

7.3.4 Method of test

7.3.4.1 Initial conditions

- (1) Connect the BS tester (UE simulator), generating the wanted signal, and a band-limited white noise source, generating the interfering AWGN signal, to the antenna connector of one BS Rx port.
- (2) Terminate any other BS Rx port not under test.
- (3) Set up a call between the BS tester and the BS. The characteristics of the call shall be according to the 12,2 kbit/s UL reference measurement channel specified in Annex A.2.1.
- (4) The level of the BS tester output signal measured at the BS antenna connector shall be adjusted to ~~to~~ (-110 + 30) dBm as specified in table 7.3.2.1.
- (5) The power spectral density of the band-limited white noise source measured at the BS antenna connector shall be adjusted as specified in table 7.3.2.1. The minimum bandwidth of the white noise source shall be 1,5 times the chip rate (5,76 MHz for a chip rate of 3,84 MHz).

7.3.4.2 Procedure

- (1) Measure the BER by comparing the bit sequence of the information data transmitted by the BS tester with the bit sequence obtained from the BS receiver.

(2) Interchange the connections of the BS Rx ports and repeat the measurement according to (1)

7.3.5 Test requirements

For any BS Rx port tested, the measured BER shall not exceed 0,001.

CHANGE REQUEST

Please see embedded help file at the bottom of this page for instructions on how to fill in this form correctly.

25.142 CR 016

Current Version: **3.1.0**

GSM (AA.BB) or 3G (AA.BBB) specification number ↑

↑ CR number as allocated by MCC support team

For submission to: **RAN #8**
list expected approval meeting # here ↑

for approval
for information

strategic
non-strategic (for SMG use only)

Form: CR cover sheet, version 2 for 3GPP and SMG The latest version of this form is available from: <ftp://ftp.3gpp.org/Information/CR-Form-v2.doc>

Proposed change affects: (U)SIM ME UTRAN / Radio Core Network
(at least one should be marked with an X)

Source: **RAN WG4** **Date:** **22.5.2000**

Subject: **Correction of the interfering power level for testing of performance requirements**

Work item: **TS 25.142**

Category: F Correction **Release:** Phase 2
A Corresponds to a correction in an earlier release Release 96
(only one category shall be marked with an X) B Addition of feature Release 97
C Functional modification of feature Release 98
D Editorial modification Release 99
Release 00

Reason for change: **Alignment of the conformance test description for performance requirements with recent amendments proposed to be incorporated into the core specification TS 25.105**

Clauses affected: **8**

Other specs affected: Other 3G core specifications → List of CRs:
Other GSM core specifications → List of CRs:
MS test specifications → List of CRs:
BSS test specifications → List of CRs:
O&M specifications → List of CRs:

Other comments:

8 Performance requirements

8.1 General

Performance requirements for the BS are specified for the measurement channels defined in Annex A and the propagation conditions in Annex B. The requirements only apply to those measurement channels that are supported by the base station.

The minimum bandwidth of the white noise source, simulating interference from other cells (I_{oc}) shall be 1.5 times the chip rate (5.76 MHz for a chip rate of 3.84 MHz).

The requirements only apply to a base station with dual receiver antenna diversity. The required \hat{I}_{or}/I_{oc} shall be applied separately at each antenna port.

Table 8.1.1: Summary of Base Station performance targets

Physical channel	Measurement channel	Static	Multi-path Case 1	Multi-path Case 2	Multi-path Case 3
		Performance metric			
DCH	12,2 kbps	BLER < 10^{-2}	BLER < 10^{-2}	BLER < 10^{-2}	BLER < 10^{-2}
	64 kbps	BLER < $10^{-1}, 10^{-2}$	BLER < $10^{-1}, 10^{-2}$	BLER < $10^{-1}, 10^{-2}$	BLER < $10^{-1}, 10^{-2}, 10^{-3}$
	144 kbps	BLER < $10^{-1}, 10^{-2}$	BLER < $10^{-1}, 10^{-2}$	BLER < $10^{-1}, 10^{-2}$	BLER < $10^{-1}, 10^{-2}, 10^{-3}$
	384 kbps	BLER < $10^{-1}, 10^{-2}$	BLER < $10^{-1}, 10^{-2}$	BLER < $10^{-1}, 10^{-2}$	BLER < $10^{-1}, 10^{-2}, 10^{-3}$

8.2 Demodulation in static propagation conditions

8.2.1 Demodulation of DCH

8.2.1.1 Definition and applicability

The performance requirement of DCH in static propagation conditions is determined by the maximum Block Error Ratio (BLER) allowed when the receiver input signal is at a specified \hat{I}_{or}/I_{oc} limit. The BLER is calculated for each of the measurement channels supported by the base station.

The requirements in this subclause shall apply to base stations intended for general-purpose applications.

8.2.1.2 Conformance requirements

For the parameters specified in table 8.2.1.2.1, the BLER should not exceed the piece-wise linear BLER curve specified in table 8.2.1.2.2.

Table 8.2.1.2.1: Parameters in static propagation conditions

Parameters	Unit	Test 1	Test 2	Test 3	Test 4
Number of DPCH _o		6	4	0	0
$\frac{DPCH_o - E_c}{I_{or}}$	dB	-9	-9,5	-	-
I_{oc}	dBm/3,84 MHz	-89 -60			
Information Data Rate	kbps	12,2	64	144	384

Table 8.2.1.2.2: Performance requirements in AWGN channel.

Test Number	$\frac{\hat{I}_{or}}{I_{oc}}$ [dB]	BLER
1	-1,9	10^{-2}
2	-0,3	10^{-1}
	0,0	10^{-2}
3	0,0	10^{-1}
	0,2	10^{-2}
4	-0,5	10^{-1}
	-0,3	10^{-2}

The reference for this requirement is TS 25.105 subclause 8.2.1.

8.2.1.3 Test purpose

The test purpose is to verify the ability of the BS to receive a prescribed test signal under static propagation conditions with a BLER not exceeding a specified limit. Within the wanted channel, intracell interference sources as well as an additional intercell interference source are taken into account. Therefore, this test – as all other tests in clause 8 - mainly checks the ability of the signal processing part of the receiver to extract the wanted signal from the interfered-with input signal, whereas the tests in clause 7 concentrate on the receiver RF part.

8.2.1.4 Method of test

8.2.1.4.1 Initial conditions

Connect the BS tester (UE simulator) generating the wanted signal and a set of interference generators to both BS antenna connectors for diversity reception via a combining network. The set of interference generators comprises a number of CDMA generators, each representing an individual intracell interferer (subsequently called DPCH₀ generators), and an additional band-limited white noise source, simulating interference from other cells. Each DPCH₀ generator shall produce an interfering signal that is equivalent to a valid UTRA TDD signal with spreading factor 16, using the same time slot(s) than the wanted signal and applying the same cell-specific scrambling code. The number of the DPCH₀ generators used in each test is given in table 8.2.1.2.1.

8.2.1.4.2 Procedure

- (1) Adjust the power of the band-limited white noise source in such a way that its power spectral density measured at the BS antenna connector takes on the value I_{oc} as specified in table 8.2.1.2.1.
- (2) For a given test defined by the information data rate and the BLER objective, set the power of each DPCH₀ measured at the BS antenna connector during the active time slots to the value specified in table 8.2.1.4.2.1.
- (3) Set up a call between the BS tester generating the wanted signal and the BS. The characteristics of the call shall be configured according to the information data rate to be provided and the corresponding UL reference measurement channel defined in Annex A. Depending on the information data rate, the UL reference measurement channel makes use of one or two Dedicated Physical Channels (DPCH₁ and DPCH₂) with different spreading factors SF. The power(s) of DPCH₁ and DPCH₂ (if applicable) measured at the BS antenna connector during the active time slots shall be set to the value(s) given in table 8.2.1.4.2.1.
- (4) Measure the BLER of the wanted signal at the BS receiver.

Table 8.2.1.4.2.1: Parameters of DPCH₀ and the wanted signal

Test Number	BLER objective	Number of DPCH ₀	Power of each DPCH ₀ measured at the BS antenna connector [dBm]	Parameters of the wanted signal		
				DPCH	SF	Power measured at the BS antenna connector [dBm]
1	10 ⁻²	6	-70,9	DPCH ₁	8	-67,9
2	10 ⁻¹	4	-69,8	DPCH ₁	16	-69,8
				DPCH ₂	4	-63,8
	10 ⁻²	4	-69,5	DPCH ₁	16	-69,5
				DPCH ₂	4	-63,5
3	10 ⁻¹	0	-	DPCH ₁	16	-69,5
				DPCH ₂	2	-60,5
	10 ⁻²	0	-	DPCH ₁	16	-69,3
				DPCH ₂	2	-60,3
4	10 ⁻¹	0	-	DPCH ₁	2	-60,5
				DPCH ₁	2	-60,3
	10 ⁻²	0	-	DPCH ₁	2	-60,3

8.2.1.5 Test requirements

The BLER measured according to subclause 8.2.1.4.2 shall not exceed the limits specified in table 8.2.1.2.2.

8.3 Demodulation of DCH in multipath fading conditions

8.3.1 Multipath fading Case 1

8.3.1.1 Definition and applicability

The performance requirement of DCH in multipath fading Case 1 is determined by the maximum Block Error Ratio (BLER) allowed when the receiver input signal is at a specified \hat{I}_{or}/I_{oc} limit. The BLER is calculated for each of the measurement channels supported by the base station.

The requirements in this subclause shall apply to base stations intended for general-purpose applications.

8.3.1.2 Conformance requirements

For the parameters specified in table 8.3.1.2.1, the BLER should not exceed the piece-wise linear BLER curve specified in table 8.3.1.2.2.

Table 8.3.1.2.1: Parameters in multipath Case 1 channel

Parameters	Unit	Test 1	Test 2	Test 3	Test 4
Number of DPCH ₀		6	4	0	0
$\frac{DPCH_o - E_c}{I_{or}}$	dB	-9	-9,5	-	-
I_{oc}	dBm/3,84 MHz	-89-60			
Information Data Rate	kbps	12,2	64	144	384

Table 8.3.1.2.2: Performance requirements in multipath Case 1 channel.

Test Number	$\frac{\hat{I}_{or}}{I_{oc}}$ [dB]	BLER
1	6,3	10^{-2}
2	5,5	10^{-1}
	9,4	10^{-2}
3	5,6	10^{-1}
	9,4	10^{-2}
4	5,5	10^{-1}
	8,7	10^{-2}

The reference for this requirement is TS 25.105 subclause 8.3.1.

8.3.1.3 Test purpose

The test purpose is to verify the ability of the BS to receive a prescribed test signal under defined propagation conditions (multipath fading Case 1) with a BLER not exceeding a specified limit. Within the wanted channel, independent intracell interference sources as well as an additional intercell interference source are taken into account. Therefore, this test – as all other tests in clause 8 - mainly checks the ability of the signal processing part of the receiver to extract the wanted signal from the distorted and interfered-with input signal, whereas the tests in clause 7 concentrate on the receiver RF part.

8.3.1.4 Method of test

8.3.1.4.1 Initial conditions

- (1) Connect the BS tester (UE simulator) generating the wanted signal and a set of interference generators to both BS antenna connectors for diversity reception via a combining network. The set of interference generators comprises a number of CDMA generators, each representing an individual intracell interferer (subsequently called DPCH₀ generators), and an additional band-limited white noise source, simulating interference from other cells. Each DPCH₀ generator shall produce an interfering signal that is equivalent to a valid UTRA TDD signal with spreading factor 16, using the same time slot(s) than the wanted signal and applying the same cell-specific scrambling code. The number of the DPCH₀ generators used in each test is given in table 8.3.1.2.1.
- (2) The wanted signal produced by the BS tester and the interfering signals produced by the DPCH₀ generators are individually passed through independent Multipath Fading Simulators (MFS) before entering the combining network. Each MFS shall be configured to simulate multipath fading Case 1.

8.3.1.4.2 Procedure

- (1) Adjust the power of the band-limited white noise source in such a way that its power spectral density measured at the BS antenna connector takes on the value I_{oc} as specified in table 8.3.1.2.1.
- (2) For a given test defined by the information data rate and the BLER objective, set the power of each DPCH₀ measured at the BS antenna connector during the active time slots to the value specified in table 8.3.1.4.2.1.
- (3) Set up a call between the BS tester generating the wanted signal and the BS. The characteristics of the call shall be configured according to the information data rate to be provided and the corresponding UL reference measurement channel defined in Annex A. Depending on the information data rate, the UL reference measurement channel makes use of one or two Dedicated Physical Channels (DPCH₁ and DPCH₂) with different spreading factors SF.

The power(s) of DPCH₁ and DPCH₂ (if applicable) measured at the BS antenna connector during the active time slots shall be set to the value(s) given in table 8.3.1.4.2.1.

- (4) Measure the BLER of the wanted signal at the BS receiver.

Table 8.3.1.4.2.1: Parameters of DPCH₀ and the wanted signal

Test Number	BLER objective	Number of DPCH ₀	Power of each DPCH ₀ measured at the BS antenna connector [dBm]	Parameters of the wanted signal		
				DPCH	SF	Power measured at the BS antenna connector [dBm]
1	10 ⁻²	6	-62,7	DPCH ₁	8	-59,7
2	10 ⁻¹	4	-64	DPCH ₁	16	-64
	10 ⁻²	4	-60,1	DPCH ₂	4	58
DPCH ₁				16	-60,1	
3	10 ⁻¹	0	-	DPCH ₁	16	-63,9
				DPCH ₂	2	-54,9
	10 ⁻²	0	-	DPCH ₁	16	-60,1
				DPCH ₂	2	-51,1
4	10 ⁻¹	0	-	DPCH ₁	2	-54,5
	10 ⁻²	0	-	DPCH ₁	2	-51,3

8.3.1.5 Test requirements

The BLER measured according to subclause 8.3.1.4.2 shall not exceed the limits specified in table 8.3.1.2.2.

8.3.2 Multipath fading Case 2

8.3.2.1 Definition and applicability

The performance requirement of DCH in multipath fading Case 2 is determined by the maximum Block Error Ratio (BLER) allowed when the receiver input signal is at a specified \hat{I}_{or}/I_{oc} limit. The BLER is calculated for each of the measurement channels supported by the base station.

The requirements in this subclause shall apply to base stations intended for general-purpose applications.

8.3.2.2 Conformance requirements

For the parameters specified in table 8.3.2.2.1, the BLER should not exceed the piece-wise linear BLER curve specified in table 8.3.2.2.2.

Table 8.3.2.2.1: Parameters in multipath Case 2 channel

Parameters	Unit	Test 1	Test 2	Test 3	Test 4
Number of DPCH ₀		2	0	0	0
$\frac{DPCH_o - E_c}{I_{or}}$	dB	-6	-	-	-
I_{oc}	dBm/3,84 MHz	-89-60			
Information Data Rate	kbps	12,2	64	144	384

Table 8.3.2.2.2: Performance requirements in multipath Case 2 channel.

Test Number	$\frac{\hat{I}_{or}}{I_{oc}}$ [dB]	BLER
1	0,1	10^{-2}
2	0,4	10^{-1}
	2,8	10^{-2}
3	3,6	10^{-1}
	6,0	10^{-2}
4	3,0	10^{-1}
	5,4	10^{-2}

The reference for this requirement is TS 25.105 subclause 8.3.2.

8.3.2.3 Test purpose

The test purpose is to verify the ability of the BS to receive a prescribed test signal under defined propagation conditions (multipath fading Case 2) with a BLER not exceeding a specified limit. Within the wanted channel, independent intracell interference sources as well as an additional intercell interference source are taken into account. Therefore, this test – as all other tests in clause 8 - mainly checks the ability of the signal processing part of the receiver to extract the wanted signal from the distorted and interfered-with input signal, whereas the tests in clause 7 concentrate on the receiver RF part.

8.3.2.4 Method of test

8.3.2.4.1 Initial conditions

- (1) Connect the BS tester (UE simulator) generating the wanted signal and a set of interference generators to both BS antenna connectors for diversity reception via a combining network. The set of interference generators comprises a number of CDMA generators, each representing an individual intracell interferer (subsequently called DPCH₀ generators), and an additional band-limited white noise source, simulating interference from other cells. Each DPCH₀ generator shall produce an interfering signal that is equivalent to a valid UTRA TDD signal with spreading factor 16, using the same time slot(s) than the wanted signal and applying the same cell-specific scrambling code. The number of the DPCH₀ generators used in each test is given in table 8.3.2.2.1.
- (2) The wanted signal produced by the BS tester and the interfering signals produced by the DPCH₀ generators are individually passed through independent Multipath Fading Simulators (MFS) before entering the combining network. Each MFS shall be configured to simulate multipath fading Case 2.

8.3.2.4.2 Procedure

- (1) Adjust the power of the band-limited white noise source in such a way that its power spectral density measured at the BS antenna connector takes on the value I_{oc} as specified in table 8.3.2.2.1.
- (2) For a given test defined by the information data rate and the BLER objective, set the power of each DPCH₀ measured at the BS antenna connector during the active time slots to the value specified in table 8.3.2.4.2.1.
- (3) Set up a call between the BS tester generating the wanted signal and the BS. The characteristics of the call shall be configured according to the information data rate to be provided and the corresponding UL reference measurement channel defined in Annex A. Depending on the information data rate, the UL reference measurement channel makes use of one or two Dedicated Physical Channels (DPCH₁ and DPCH₂) with different spreading factors SF. The power(s) of DPCH₁ and DPCH₂ (if applicable) measured at the BS antenna connector during the active time slots shall be set to the value(s) given in table 8.3.2.4.2.1.
- (4) Measure the BLER of the wanted signal at the BS receiver.

Table 8.3.2.4.2.1: Parameters of DPCH₀ and the wanted signal

Test Number	BLER objective	Number of DPCH ₀	Power of each DPCH ₀ measured at the BS antenna connector [dBm]	Parameters of the wanted signal		
				DPCH	SF	Power measured at the BS antenna connector [dBm]
1	10 ⁻²	2	-65,9	DPCH ₁	8	-62,9
2	10 ⁻¹	0	-	DPCH ₁	16	-66,6
				DPCH ₂	4	-60,6
	10 ⁻²	0	-	DPCH ₁	16	-64,2
				DPCH ₂	4	-58,2
3	10 ⁻¹	0	-	DPCH ₁	16	-65,9
				DPCH ₂	2	-56,9
	10 ⁻²	0	-	DPCH ₁	16	-63,5
				DPCH ₂	2	-54,5
4	10 ⁻¹	0	-	DPCH ₁	2	-57
	10 ⁻²	0	-	DPCH ₁	2	-54,6

8.3.2.5 Test requirements

The BLER measured according to subclause 8.3.2.4.2 shall not exceed the limits specified in table 8.3.2.2.2.

8.3.3 Multipath fading Case 3

8.3.3.1 Definition and applicability

The performance requirement of DCH in multipath fading Case 3 is determined by the maximum Block Error Ratio (BLER) allowed when the receiver input signal is at a specified \hat{I}_{or}/I_{oc} limit. The BLER is calculated for each of the measurement channels supported by the base station.

The requirements in this subclause shall apply to base stations intended for general-purpose applications.

8.3.3.2 Conformance requirements

For the parameters specified in table 8.3.3.2.1, the BLER should not exceed the piece-wise linear BLER curve specified in Table 8.3.3.2.2.

Table 8.3.3.2.1: Parameters in multipath Case 3 channel

Parameters	Unit	Test 1	Test 2	Test 3	Test 4
Number of DPCH ₀		2	0	0	0
$\frac{DPCH_o - E_c}{I_{or}}$	dB	-6	-	-	-
I_{oc}	dBm/3,84 MHz	-89-60			
Information Data Rate	kbps	12,2	64	144	384

Table 8.8: Performance requirements in multipath Case 3 channel.

Test Number	$\frac{\hat{I}_{or}}{I_{oc}}$ [dB]	BLER
1	-0,6	10^{-2}
2	0,7	10^{-1}
	2,4	10^{-2}
	3,8	10^{-3}
3	3,9	10^{-1}
	5,9	10^{-2}
	7,3	10^{-3}
4	2,8	10^{-1}
	4,2	10^{-2}
	4,8	10^{-3}

The reference for this requirement is TS 25.105 subclause 8.3.3.

8.3.3.3 Test purpose

The test purpose is to verify the ability of the BS to receive a prescribed test signal under defined propagation conditions (multipath fading Case 3) with a BLER not exceeding a specified limit. Within the wanted channel, independent intracell interference sources as well as an additional intercell interference source are taken into account. Therefore, this test – as all other tests in clause 8 - mainly checks the ability of the signal processing part of the receiver to extract the wanted signal from the distorted and interfered-with input signal, whereas the tests in clause 7 concentrate on the receiver RF part.

8.3.3.4 Method of test

8.3.3.4.1 Initial conditions

- (1) Connect the BS tester (UE simulator) generating the wanted signal and a set of interference generators to both BS antenna connectors for diversity reception via a combining network. The set of interference generators comprises a number of CDMA generators, each representing an individual intracell interferer (subsequently called DPCH₀ generators), and an additional band-limited white noise source, simulating interference from other cells. Each DPCH₀ generator shall produce an interfering signal that is equivalent to a valid UTRA TDD signal with spreading factor 16, using the same time slot(s) than the wanted signal and applying the same cell-specific scrambling code. The number of the DPCH₀ generators used in each test is given in table 8.3.3.2.1.
- (2) The wanted signal produced by the BS tester and the interfering signals produced by the DPCH₀ generators are individually passed through independent Multipath Fading Simulators (MFS) before entering the combining network. Each MFS shall be configured to simulate multipath fading Case 3.

8.3.3.4.2 Procedure

- (1) Adjust the power of the band-limited white noise source in such a way that its power spectral density measured at the BS antenna connector takes on the value I_{oc} as specified in table 8.3.3.2.1.
- (2) For a given test defined by the information data rate and the BLER objective, set the power of each DPCH₀ measured at the BS antenna connector during the active time slots to the value specified in table 8.3.3.4.2.1.
- (3) Set up a call between the BS tester generating the wanted signal and the BS. The characteristics of the call shall be configured according to the information data rate to be provided and the corresponding UL reference measurement channel defined in Annex A. Depending on the information data rate, the UL reference measurement channel makes use of one or two Dedicated Physical Channels (DPCH₁ and DPCH₂) with different spreading factors SF. The power(s) of DPCH₁ and DPCH₂ (if applicable) measured at the BS antenna connector during the active time slots shall be set to the value(s) given in table 8.3.3.4.2.1.
- (4) Measure the BLER of the wanted signal at the BS receiver.

Table 8.3.3.4.2.1: Parameters of DPCH₀ and the wanted signal

Test Number	BLER objective	Number of DPCH ₀	Power of each DPCH ₀ measured at the BS antenna connector [dBm]	Parameters of the wanted signal		
				DPCH	SF	Power measured at the BS antenna connector [dBm]
1	10 ⁻²	2	-66,6	DPCH ₁	8	-63,6
2	10 ⁻¹	0	-	DPCH ₁	16	-66,3
				DPCH ₂	4	-60,3
	10 ⁻²	0	-	DPCH ₁	16	-64,6
				DPCH ₂	4	-58,6
10 ⁻³	0	-	DPCH ₁	16	-63,2	
			DPCH ₂	4	-57,2	
3	10 ⁻¹	0	-	DPCH ₁	16	-65,6
				DPCH ₂	2	-56,6
	10 ⁻²	0	-	DPCH ₁	16	-63,6
DPCH ₂				2	-54,6	
	10 ⁻³	0	-	DPCH ₁	16	-62,2
				DPCH ₂	2	-53,2
4	10 ⁻¹	0	-	DPCH ₁	2	-57,2
	10 ⁻²	0	-	DPCH ₁	2	-55,8
	10 ⁻³	0	-	DPCH ₁	2	-55,2

8.3.3.5 Test requirements

The BLER measured according to subclause 8.3.3.4.2 shall not exceed the limits specified in table 8.3.3.2.2.

CHANGE REQUEST

Please see embedded help file at the bottom of this page for instructions on how to fill in this form correctly.

25.142 CR 017

Current Version: **3.1.0**

GSM (AA.BB) or 3G (AA.BBB) specification number ↑

↑ CR number as allocated by MCC support team

For submission to: **RAN #8**
list expected approval meeting # here ↑

for approval
for information

strategic
non-strategic (for SMG use only)

Form: CR cover sheet, version 2 for 3GPP and SMG The latest version of this form is available from: <ftp://ftp.3gpp.org/Information/CR-Form-v2.doc>

Proposed change affects:
(at least one should be marked with an X)

(U)SIM ME UTRAN / Radio Core Network

Source:

RAN WG4

Date:

22.5.2000

Subject:

Definitions of maximum output power and rated output power

Work item:

TS 25.142

Category:

F Correction
A Corresponds to a correction in an earlier release
B Addition of feature
C Functional modification of feature
D Editorial modification

(only one category shall be marked with an X)

Release:

Phase 2
Release 96
Release 97
Release 98
Release 99
Release 00

Reason for change:

Alignment of the definitions of maximum output power and rated output power with recent amendments incorporated into the core specification TS 25.105 via CR 025 and CR 026

Clauses affected:

3, 5.2, 6.2.1, 6.2.2, 6.2.4.1, 6.3.4.1, 6.4.5.2, 6.4.5.4.1, 6.5.4.1, 6.6.1.4.1, 6.6.2.1.4.1, 6.6.2.2.4.1, 6.6.3.4.1, 6.7.4.1, 6.8.2.4.1, 7.7.4.1

Other specs affected:

Other 3G core specifications → List of CRs:
Other GSM core specifications → List of CRs:
MS test specifications → List of CRs:
BSS test specifications → List of CRs:
O&M specifications → List of CRs:

Other comments:

3 Definitions, symbols, and abbreviations

For the purposes of the present document, the following definitions, symbols and abbreviations apply:

3GPP	3rd Generation Partnership Project
α	Roll-off factor
dB	decibel
dBm	decibel relative to 1 milliWatt
DPCHo	Mechanism used to simulate an individual intracell interferer in the cell with one code and a spreading factor of 16
$\frac{DPCH_o - E_c}{I_{or}}$	Ratio of the average transmit energy per PN chip for the DPCH _o to the total transmit power
	spectral density of all users in the cell in one timeslot as measured at the BS antenna connector
EVM	Error Vector Magnitude
F	Frequency (of the assigned channel frequency of the wanted signal)
F _w	Frequency offset of the unwanted interfering signal from the assigned channel frequency of the wanted signal
IMT-2000	International Mobile Telecommunications 2000
I _{oc}	Power spectral density of a band limited white noise source (simulating interference from other cells) as measured at the BS antenna connector.
\hat{I}_{or}	Received power spectral density of all users in the cell in one timeslot as measured at the BS antenna connector
IPR	Intellectual Property Rights
P	Transmit power
P _{out}	<u>Output power of the base station; defined as the mean power of one carrier delivered to a load with resistance equal to the nominal load impedance of the transmitter during one slot</u>
P _{max}	<u>Maximum output power of the base station; defined as the mean power level per carrier over an active timeslot measured at the antenna connector for a specified reference condition</u>
RBER	Residual BER
REFSENS	Reference Sensitivity Level
RMS	Root-Mean Square
PRAT	<u>Rated output power of the base station; defined as the mean power level per carrier over an active timeslot that the manufacturer has declared to be available at the antenna connector</u>
RRC	Root-Raised Cosine
T _c	Chip duration
TS	Time Slot

5 General test conditions and declarations

The requirements of this clause apply to all tests in this TS, when applicable.

The general conditions during the tests should be according to the relevant parts of ETR 027 [2] (methods of measurement for mobile radio equipment) with the exceptions and additions defined in the individual tests.

Many of the tests in this TS measure a parameter relative to a value which is not fully specified in the UTRA specifications. For these tests, the conformance requirement is determined relative to a nominal value specified by the manufacturer.

Certain functions of a BS are optional in the UTRA specifications.

When specified in a test, the manufacturer shall declare the nominal value of a parameter, or whether an option is supported.

5.1 Base station classes

The requirements in this specification apply to base stations intended for general-purpose applications in co-ordinated network operation.

In future, further classes of base stations may be defined; the requirements for these may be different than for general-purpose applications.

5.2 Output power ~~and determination of power class~~

The manufacturer shall declare the ~~rated maximum~~ output power, PRAT, of the base station which is defined as the mean power level per carrier over an active timeslot available at the antenna connector; see subclause 6.2.

6 Transmitter characteristics

6.1 General

Unless otherwise stated, all measurements shall be made at the BS antenna connector.

6.2 Maximum output power

6.2.1 Definition and applicability

Output power, P_{out} , of the base station is the power of one carrier delivered to a load with resistance equal to the nominal load impedance, when averaged (in the sense of thermal power) over the useful part of the burst (time slot).

Rated output power, PRAT, of the base station is the mean power level per carrier over an active timeslot that the manufacturer has declared to be available at the antenna connector.

Maximum output power, P_{max} , of the base station is the mean power level per carrier over an active timeslot measured at the antenna connector for a specified reference condition ~~output power that the manufacturer has declared to be available at the antenna connector.~~

The requirements in this subclause shall apply to base stations intended for general-purpose applications.

6.2.2 Conformance requirements

In normal conditions, the base station maximum output power shall remain within +2 dB and -2 dB of the ~~available power declared by the manufacturer's~~ rated output power.

In extreme conditions, the base station maximum output power shall remain within +2,5 dB and -2,5 dB of the ~~available power declared by the manufacturer's~~ rated output power.

The reference for this requirement is TS 25.105 subclause 6.2.1.1.

6.2.3 Test purpose

The test purpose is to verify the accuracy of the maximum output power across the frequency range and under normal and extreme conditions for all transmitters in the BS.

6.2.4 Method of test

6.2.4.1 Initial conditions

- (1) The transmitter under test and all other transmitters of the base station (if any) are switched on.
- (2) The power of the transmitters not under test (if any) are controlled down.
- (3) Connect the power measuring equipment to the BS antenna connector.
- (4) Set the parameters of the transmitted signal according to table 6.2.4.1.1.

Table 6.2.4.1.1: Parameters of the transmitted signal for maximum output power test

Parameter	Value/description
TDD Duty Cycle	TS i ; $i = 0, 1, 2, \dots, 14$: transmit, if i is even; receive, if i is odd.
Base Station output power setting	PRAT maximum, according to manufacturer's declaration
Number of DPCH in each active TS	9
Power of each DPCH	1/9 of Base Station output power
Data content of DPCH	real life (sufficient irregular)

6.2.4.2 Procedure

- (1) Measure thermal power over the 2464 active chips of an even time slot (this excludes the guard periods), and with a measurement bandwidth of at least 5 MHz.
- (2) Average over TBD time slots.
- (3) Run steps (1) and (2) for RF channels Low / Mid / High.

6.2.5 Test requirements

The value of the measured output power, derived according to subclause 6.2.4.2, shall be within the tolerance defined in subclause 6.2.2.

6.3 Frequency stability

6.3.1 Definition and applicability

Frequency stability is the ability of the BS to transmit at the assigned carrier frequency.

The requirements in this subclause shall apply to base stations intended for general-purpose applications.

6.3.2 Conformance requirements

The BS frequency stability shall be within $\pm 0,05$ ppm.

The reference for this requirement is TS 25.105 subclause 6.3.1.

6.3.3 Test purpose

The test purpose is to verify the accuracy of the carrier frequency across the frequency range and under normal and extreme conditions.

6.3.4 Method of test

6.3.4.1 Initial conditions

- (1) The transmitter under test and all other transmitters of the base station (if any) are switched on.
- (2) The power of the transmitters not under test (if any) are controlled down.
- (3) Connect the tester to the BS antenna connector.
- (4) Set the parameters of the transmitted signal according to table 6.3.4.1.1.

Table 6.3.4.1.1: Parameters of the transmitted signal for frequency stability test

Parameter	Value/description
TDD Duty Cycle	TS i ; $i = 0, 1, 2, \dots, 14$: transmit, if i is even; receive, if i is odd.
Number of DPCH in each active TS	1
Base Station output power setting	PRAT maximum, according to manufacturer's declaration
Data content of DPCH	real life (sufficient irregular)

6.4.5 Primary CCPCH power

6.4.5.1 Definition and applicability

Primary CCPCH power is the transmission power of the Primary Common Control Physical Channel averaged over the transmit timeslot. Primary CCPCH power is signaled on the BCH.

The requirements in this subclause shall apply to base stations intended for general-purpose applications.

6.4.5.2 Conformance requirements

The error between the BCH-broadcast value of the Primary CCPCH power and the Primary CCPCH power averaged over the timeslot shall not exceed the values in table 6.4.5.2.1. The error is a function of the total power averaged over the timeslot, P_{out} , and the manufacturer's rated output power, PRAT.

Table 6.4.5.2.1: Errors between Primary CCPCH power and the broadcast value

Total power in slot, dB	PCCPCH power tolerance
$P_{maxPRAT} - 3 < P_{out} \leq P_{maxPRAT} + 2$	+/- 2,5 dB
$P_{maxPRAT} - 6 < P \leq P_{maxPRAT} - 3$	+/- 3,5 dB
$P_{maxPRAT} - 13 < P \leq P_{maxPRAT} - 6$	+/- 5 dB

The reference for this requirement is TS 25.105 subclause 6.4.5.

6.4.5.3 Test purpose

The power of the Primary CCPCH received by the UE, together with the information on the Primary CCPCH nominal transmit power signaled on the BCH, are used by the UE for path loss estimation and adjustment of its own transmit power. Therefore, deviations of the Primary CCPCH power from its nominal value are transposed by the UE into deviations from the wanted transmit power of the UE.

The test purpose is to verify that the Primary CCPCH power remains within its specified tolerances under normal and extreme conditions.

6.4.5.4 Method of test

6.4.5.4.1 Initial conditions

- (1) Connect the BS tester to the antenna connector of the BS under test. The BS tester must have the ability to analyze the output signal of the BS under test with respect to code domain power, by applying the global in-channel Tx test method described in Annex C.
- (2) Set the parameters of the BS transmitted signal according to table 6.4.5.4.1.1.

Table 6.4.5.4.1.1: Parameters of the BS transmitted signal for Primary CCPCH power testing

Parameter	Value/description
TDD Duty Cycle	TS i ; $i = 0, 1, 2, \dots, 14$: transmit, if i is even; receive, if i is odd.
Time slots carrying PCCPCH	TS 0 and TS 8
Number of additional DPCH in TS 0 and TS 8	3
Base Station output power setting	PRAT maximum, according to manufacturer's declaration
Relative power of PCCPCH	$\frac{1}{4}$ of BS output power
Relative power of each DPCH in TS 0 and TS 8	$\frac{1}{4}$ of BS output power
Data content of DPCH	real life (sufficient irregular)

6.4.5.4.2 Procedure

- (1) Measure the PCCPCH power in TS 0 and TS 8 by applying the global in-channel Tx test method described in Annex C.
- (2) Reduce the base station output power by 2 dB, 5 dB and 13 dB, without changing the relative powers of the PCCPCH and the DPCHs, and repeat step (1) for each output power setting.

6.4.5.5 Test requirements

The Primary CCPCH power, measured according to subclause 6.4.5.4.2, shall be within the limits defined in subclause 6.4.5.2.

6.5 Transmit OFF power

6.5.1 Definition and applicability

The transmit OFF power is the maximum residual output power within the channel bandwidth when the BS does not transmit.

6.5.2 Conformance requirements

The transmit OFF power shall be less than -79 dBm measured with a filter that has a Root-Raised Cosine (RRC) filter response with a roll-off $\alpha = 0,22$ and a bandwidth equal to the chip rate.

The reference for this requirement is TS 25.105 subclause 6.5.1.

6.5.3 Test purpose

This test verifies the ability of the BS to reduce its transmit OFF power to a value below the specified limit. This ability is needed to minimize the interference for other users receiving on the same frequency.

6.5.4 Method of test

6.5.4.1 Initial conditions

- (1) Connect the power measuring equipment to the BS antenna connector.
- (2) Set the parameters of the transmitted signal according to table 6.5.4.1.1.

Table 6.5.4.1.1 Parameters of the transmitted signal for transmit OFF power test

Parameter	Value/description
TDD Duty Cycle	TS i ; $i = 0, 1, 2, \dots, 14$: transmit, if i is even; receive, if i is odd.
Base Station output power setting	PRAT Maximum, according to manufacturer's declaration
Number of DPCH in each active TS	9
Power of each DPCH	1/9 of Base Station output power
Data content of DPCH	Real life (sufficient irregular)

6.5.4.2 Procedure

(1) Measure the power of the BS output signal chipwise (i.e. averaged over time intervals of one chip duration) over the transmit off power period starting 20 chips before the start of the odd time slots TS i (receive time slots of the BS), and ending 16 chips before the next even time slot (transmit time slot of the BS) starts, and with a measurement filter that has a RRC filter response with a roll off $\alpha = 0,22$ and a bandwidth equal to the chip rate. If the power measuring equipment is based on signal sampling, the sampling theorem shall be met. In this case, the power is determined by calculating the RMS value of the signal samples taken at the measurement filter output over one chip duration.

(2) Run steps (1) and (2) for RF channels Low / Mid / High.

6.5.5 Test requirements

The value of the transmit OFF power derived according to subclause 6.5.4.2, shall be below the limit defined in subclause 6.5.2.

6.6 Output RF spectrum emissions

6.6.1 Occupied bandwidth

6.6.1.1 Definition and applicability

Occupied bandwidth is a measure of the bandwidth containing 99% of the total integrated power for transmitted spectrum and is centered on the assigned channel frequency.

The requirements in this subclause shall apply to base stations intended for general-purpose applications.

6.6.1.2 Conformance requirements

The occupied bandwidth shall be less than 5 MHz based on a chip rate of 3,84 Mcps.

The reference for this requirement is TS 25.105 subclause 6.6.1.

6.6.1.3 Test purpose

The occupied bandwidth, defined in the Radio Regulations of the International Telecommunication Union ITU, is a useful concept for specifying the spectral properties of a given emission in the simplest possible manner; see also Recommendation ITU-R SM.328-9 [7]. The test purpose is to verify that the emission of the BS does not occupy an excessive bandwidth for the service to be provided and is, therefore, not likely to create interference to other users of the spectrum beyond undue limits.

6.6.1.4 Method of test

6.6.1.4.1 Initial conditions

- (1) Connect the measuring equipment to the antenna connector of the BS under test.
- (2) Set the parameters of the BS transmitted signal according to table 6.6.1.4.1.1.

Table 6.6.1.4.1.1: Parameters of the BS transmitted signal for occupied bandwidth testing

Parameter	Value/description
TDD Duty Cycle	TS i ; $i = 0, 1, 2, \dots, 14$: transmit, if i is even; receive, if i is odd.
Base Station output power <u>setting</u>	PRAT Maximum, according to manufacturer's declaration
Number of DPCH in each active TS	9
Power of each DPCH	1/9 of Base Station output power
Data content of DPCH	Real life (sufficient irregular)

6.6.2.1.4 Method of test

6.6.2.1.4.1 Initial conditions

- (1) Connect the measuring equipment to the antenna connector of the BS under test.
- (2) Set the parameters of the BS transmitted signal according to table 6.6.2.1.4.1.1.

Table 6.6.2.1.4.1.1: Parameters of the BS transmitted signal for spectrum emission mask testing

Parameter	Value/description
TDD Duty Cycle	TS i ; $i = 0, 1, 2, \dots, 14$: transmit, if i is even; receive, if i is odd.
Base Station output power setting	PRAT maximum, according to Manufacturer's declaration
Number of DPCH in each active TS	9
Power of each DPCH	1/9 of Base Station output power
Data content of DPCH	real life (sufficient irregular)

6.6.2.2.4 Method of test

~~6.6.2.2.4.1 Initial conditions~~

- ~~(1) Connect the measuring equipment to the antenna connector of the BS under test.~~
- ~~(2) Set the parameters of the BS transmitted signal according to table 6.6.2.2.4.1.1.~~

Table 6.6.2.2.4.1.1: Parameters of the BS transmitted signal for ACLR testing

Parameter	Value/description
TDD Duty Cycle	TS i ; $i = 0, 1, 2, \dots, 14$: ——— transmit, if i is even; ——— receive, if i is odd.
Base Station output power	Maximum, according to Manufacturer's declaration
Number of DPCH in each active TS	9
Power of each DPCH	1/9 of Base Station output power
Data content of DPCH	Real life (sufficient irregular)

6.6.2.2.4.1 Initial conditions

- (1) Connect the measuring equipment to the antenna connector of the BS under test.
- (2) Set the parameters of the BS transmitted signal according to table 6.6.2.2.4.1.1.

Table 6.6.2.2.4.1.1: Parameters of the BS transmitted signal for ACLR testing

Parameter	Value/description
TDD Duty Cycle	TS i ; $i = 0, 1, 2, \dots, 14$: transmit, if i is even; receive, if i is odd.
Base Station output power <u>setting</u>	<u>PRAT</u> maximum, according to Manufacturer's declaration
Number of DPCH in each active TS	9
Power of each DPCH	1/9 of Base Station output power
Data content of DPCH	real life (sufficient irregular)

6.6.3.4 Method of test

6.6.3.4.1 Initial conditions

- (1) Connect the measuring equipment to the antenna connector of the BS under test.
- (2) Set the parameters of the BS transmitted signal according to table 6.6.3.4.1.1.

Table 6.6.3.4.1.1: Parameters of the BS transmitted signal for spurious emissions testing

Parameter	Value/description
TDD Duty Cycle	TS i ; $i = 0, 1, 2, \dots, 14$: transmit, if i is even; receive, if i is odd.
Base Station output power <u>setting</u>	PRAT maximum, according to manufacturer's declaration
Number of DPCH in each active TS	9
Power of each DPCH	1/9 of Base Station output power
Data content of DPCH	real life (sufficient irregular)

6.7.4 Method of test

6.7.4.1 Initial conditions

(1) Connect the measuring equipment, the BS under test and the CDMA signal generator as shown in figure 6.7.4.1.1.

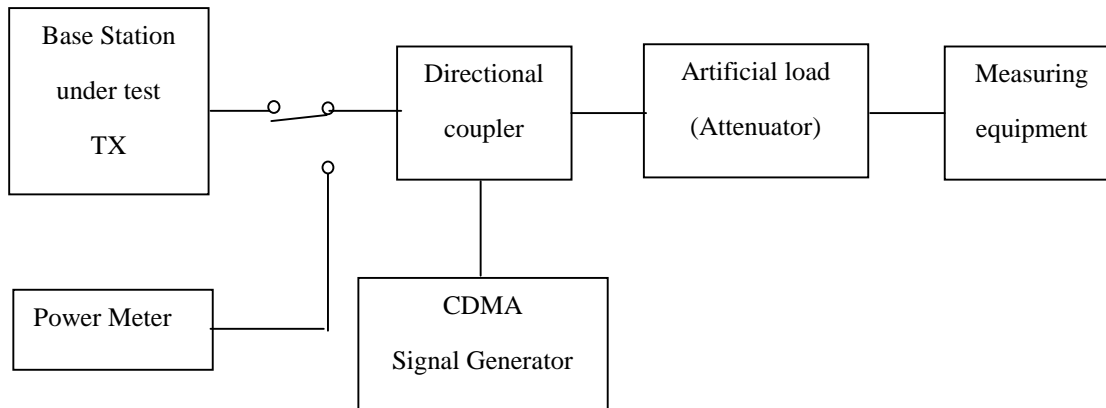

Figure 6.7.4.1.1: Measuring setup for Base Station transmit intermodulation testing

(2) Set the parameters of the BS transmitted signal according to table 6.7.4.1.1.

Table 6.7.4.1.1: Parameters of the BS transmitted signal for transmit intermodulation testing

Parameter	Value/description
TDD Duty Cycle	TS i ; $i = 0, 1, 2, \dots, 14$: transmit, if i is odd; receive, if i is even.
Base Station output power setting	PRAT maximum, according to manufacturer's declaration
Number of DPCH in each active TS	9
Power of each DPCH	1/9 of Base Station output power
Data content of DPCH	real life (sufficient irregular)

6.8.2.4 Method of test

6.8.2.4.1 Initial conditions

- (1) Connect the measuring equipment to the antenna connector of the BS under test.
- (2) Set the parameters of the BS transmitted signal according to table 6.8.2.4.1.1.

Table 6.8.2.4.1.1: Parameters of the BS transmitted signal

Parameter	Value/description
TDD Duty Cycle	TS i ; $i = 0, 1, 2, \dots, 14$: transmit, if i is even; receive, if i is odd.
Base Station output power <u>setting</u>	PRAT maximum, according to manufacturer's declaration
Number of DPCH in each active TS	9
Power of each DPCH	1/9 of Base Station output power
Data content of DPCH	real life (sufficient irregular)
Spreading factor	16

7.7 Spurious emissions

7.7.1 Definition and applicability

The spurious emissions power is the power of emissions generated or amplified in a receiver that appear at the BS antenna connector. The requirements apply to all BS with separate Rx and Tx antenna connectors. For BS equipped with only a single antenna connector for both transmitter and receiver, the requirements of subclause 6.6.3 shall apply to this port, and this test need not be performed.

The requirements in this subclause shall apply to base stations intended for general-purpose applications.

7.7.2 Conformance requirements

The power of any spurious emission shall not exceed the values given in table 7.7.2.1.

Table 7.7.2.1: Receiver spurious emission requirements

Band	Maximum level	Measurement Bandwidth	Note
9 kHz – 1 GHz	-57 dBm	100 kHz	
1 GHz – 1,9 GHz	-47 dBm	1 MHz	With the exception of frequencies between 12,5 MHz below the first carrier frequency and 12,5 MHz above the last carrier frequency used by the BS
1,900 – 1,980 GHz	-78 dBm	3,84 MHz	With the exception of frequencies between 12,5 MHz below the first carrier frequency and 12,5 MHz above the last carrier frequency used by the BS
1,980 – 2,010 GHz	-47 dBm	1 MHz	With the exception of frequencies between 12,5 MHz below the first carrier frequency and 12,5 MHz above the last carrier frequency used by the BS
2,010 – 2,025 GHz	-78 dBm	3,84 MHz	With the exception of frequencies between 12,5 MHz below the first carrier frequency and 12,5 MHz above the last carrier frequency used by the BS
2,025 GHz – 12,75 GHz	-47 dBm	1 MHz	With the exception of frequencies between 12,5 MHz below the first carrier frequency and 12,5 MHz above the last carrier frequency used by the BS

The reference for this requirement is TS 25.105 subclause 7.7.1.

7.7.3 Test purpose

The test purpose is to verify the ability of the BS to limit the interference caused by receiver spurious emissions to other systems.

7.7.4 Method of test

7.7.4.1 Initial conditions

- (1) Connect the measuring equipment to the antenna connector of one BS Rx port.
- (2) Terminate any other BS Rx port not under test.
- (3) Set the BS receiver to operational mode.

- (4) Set the BS to transmit a signal with parameters according to table 7.7.4.1.1.
- (5) Terminate the Tx port(s).

Table 7.7.4.1.1: Parameters of the transmitted signal for Rx spurious emissions test

Parameter	Value/description
TDD Duty Cycle	TS i ; $i = 0, 1, 2, \dots, 14$: transmit, if i is even; receive, if i is odd.
Base Station output power setting	PRAT maximum, according to manufacturer's declaration
Number of DPCH in each active TS	9
Power of each DPCH	1/9 of Base Station output power
Data content of DPCH	real life (sufficient irregular)

CHANGE REQUEST

Please see embedded help file at the bottom of this page for instructions on how to fill in this form correctly.

25.142 CR 018

Current Version: **3.1.0**

GSM (AA.BB) or 3G (AA.BBB) specification number ↑

↑ CR number as allocated by MCC support team

For submission to: **RAN #8**
list expected approval meeting # here ↑

for approval
for information

strategic
non-strategic (for SMG use only)

Form: CR cover sheet, version 2 for 3GPP and SMG The latest version of this form is available from: <ftp://ftp.3gpp.org/Information/CR-Form-v2.doc>

Proposed change affects:
(at least one should be marked with an X)

(U)SIM ME UTRAN / Radio Core Network

Source: RAN WG4

Date: 22.5.2000

Subject: Correction of blocking requirements

Work item: TS 25.142

Category:

F Correction
A Corresponds to a correction in an earlier release
B Addition of feature
C Functional modification of feature
D Editorial modification

(only one category shall be marked with an X)

Release:

Phase 2
Release 96
Release 97
Release 98
Release 99
Release 00

Reason for change:

Alignment of the blocking requirements with recent amendments incorporated into the core specification TS 25.105 via CR 019r1

Clauses affected: 5.7, 7.5

Other specs affected:

Other 3G core specifications → List of CRs:
Other GSM core specifications → List of CRs:
MS test specifications → List of CRs:
BSS test specifications → List of CRs:
O&M specifications → List of CRs:

Other comments:

5.7 Blocking characteristics

The conformance requirements with respect to the parameter blocking characteristics are dependent on the operating frequency bands of the BS under test; see subclause 7.5.2. However, no additional declaration is required; the need for a manufacturer's declaration of the frequency bands supported by the BS is already covered by subclause 5.3. The relationship between the frequency bands supported by the BS and the mandatory blocking requirements is given in table 5.7.1.

~~If the manufacturer has declared that the BS supports the frequency bands defined in subclause 4.2 a), compliance with the conformance requirements specified in table 7.5.2.1 is mandatory. If the manufacturer has declared that the BS supports the frequency bands defined in subclause 4.2 b) or 4.2 c), compliance with the conformance requirements specified in table 7.5.2.2 is mandatory.~~

Table 5.7.1: Relationship between the frequency bands supported by the BS and the mandatory blocking requirements

<u>Supported frequency band according to manufacturer's declaration</u>	<u>Mandatory blocking requirement</u>
<u>subclause 4.2a)</u>	<u>table 7.5.2.1</u>
<u>subclause 4.2b)</u>	<u>table 7.5.2.2</u>
<u>subclause 4.2c)</u>	<u>table 7.5.2.3</u>

7.5 Blocking characteristics

7.5.1 Definition and applicability

The blocking characteristics is a measure of the receiver ability to receive a wanted signal at its assigned channel frequency in the presence of an unwanted interferer on frequencies other than those of the adjacent channels. The blocking performance shall apply at all frequencies as specified in tables 7.5.2.1, ~~7.5.2.2~~ or 7.5.2.3, respectively, using a 1 MHz step size.

The requirements in this subclause shall apply to base stations intended for general-purpose applications.

7.5.2 Conformance requirements

The static reference performance as specified in clause 7.2 should be met with a wanted and an interfering signal coupled to the BS antenna input using the parameters specified in tables 7.5.2.1 or 7.5.2.2, respectively.

Table 7.5.2.1: Blocking requirements for operating bands defined in subclause 4.2 a)

Center frequency of interfering signal	Interfering signal level	Wanted signal level	Minimum offset of interfering signal	Type of interfering signal
1900 – 1920 MHz, 2010 – 2025 MHz	-40 dBm	<REFSENS> + 6 dB	10 MHz	WCDMA signal with one code
1880 – 1900 MHz, 1990 – 2010 MHz, 2025 – 2045 MHz	-40 dBm	<REFSENS> + 6 dB	10 MHz	WCDMA signal with one code
1920 – 1980 MHz	-40 dBm	<REFSENS> + 6 dB	10 MHz	WCDMA signal with one code
1 - 1880 MHz, 1980 – 1990 MHz, 2045 – 12750 MHz	-15 dBm	<REFSENS> + 6 dB	—	CW carrier

Table 7.5.2.2: Blocking requirements for operating bands defined in subclause 4.2 b), c)

Center frequency of interfering signal	Interfering signal level	Wanted signal level	Minimum offset of interfering signal	Type of interfering signal
1850 – 1990 MHz	-40 dBm	<REFSENS> + 6 dB	10 MHz	WCDMA signal with one code
1830 – 1850 MHz, 1990 – 2010 MHz	-40 dBm	<REFSENS> + 6 dB	10 MHz	WCDMA signal with one code
1 - 1830 MHz, 2045 – 12750 MHz	-15 dBm	<REFSENS> + 6 dB	—	CW carrier

Table 7.5.2.3: Blocking requirements for operating bands defined in subclause 4.2 c)

<u>Center frequency of interfering signal</u>	<u>Interfering signal level</u>	<u>Wanted signal level</u>	<u>Minimum offset of interfering signal</u>	<u>Type of interfering signal</u>
1910 – 1930 MHz	-40 dBm	<REFSENS> + 6 dB	10 MHz	WCDMA signal with one code
1890 – 1910 MHz, 1930 – 1950 MHz	-40 dBm	<REFSENS> + 6 dB	10 MHz	WCDMA signal with one code
1 - 1890 MHz, 1950 – 12750 MHz	-15 dBm	<REFSENS> + 6 dB	—	CW carrier

The reference for this requirement is TS 25.105 subclause 7.5.

7.5.3 Test purpose

The test stresses the ability of the BS receiver to withstand high-level interference from unwanted signals at frequency offsets of 10 MHz or more, without undue degradation of its sensitivity.

7.5.4 Method of test

7.5.4.1 Initial conditions

- (1) Connect an UE simulator operating at the assigned channel frequency of the wanted signal and a signal generator to the antenna connector of one Rx port.
- (2) Terminate any other Rx port not under test.
- (3) Set up a call between the UE simulator and the BS tester. The characteristics of the call shall be set according to the UL reference measurement channel (12,2 kbit/s) specified in Annex A.2.1. The level of the UE simulator signal measured at the BS antenna connector shall be set to 6 dB above the reference sensitivity level specified in subclause 7.2.2.

7.5.4.2 Procedure

- (1) Set the signal generator to produce an interfering signal at a frequency offset F_{uw} from the assigned channel frequency of the wanted signal which is given by

$$F_{uw} = \pm (n \times 1 \text{ MHz}),$$

where n shall be increased in integer steps from $n = 10$ up to such a value that the center frequency of the interfering signal covers the range from 1 MHz to 12,75 GHz. The interfering signal level measured at the antenna connector shall be set in dependency of its center frequency, as specified in tables 7.5.2.1, ~~7.5.2.2~~ or 7.5.2.3, respectively. The type of the interfering signal is either equivalent to a continuous wideband CDMA signal with one code of chip frequency 3,84 Mchip/s, filtered by an RRC transmit pulse-shaping filter with roll-off $\alpha = 0,22$, or a CW signal; see tables 7.5.2.1, ~~7.5.2.2~~ or 7.5.2.3, respectively.

- (2) Measure the BER of the wanted signal at the BS receiver.
- (3) Interchange the connections of the BS Rx ports and repeat the measurements according to steps (1) and (2).

NOTE: The test procedure as defined in steps (1) and (2) requests to carry out more than 10000 BER measurements. To reduce the time needed for these measurements, it may be appropriate to conduct the test in two phases: During phase 1, BER measurements are made on all center frequencies of the interfering signal as requested but with a reduced confidence level, with the aim to identify those frequencies which require more detailed investigation. In phase 2, detailed measurements are made only at those critical frequencies identified before, applying the required confidence level.

7.5.5 Test requirements

In all measurements made according to subclause 7.5.4.2, the BER shall not exceed 0,001.

CHANGE REQUEST

Please see embedded help file at the bottom of this page for instructions on how to fill in this form correctly.

25.142 CR 020

Current Version: **3.1.0**

GSM (AA.BB) or 3G (AA.BBB) specification number ↑

↑ CR number as allocated by MCC support team

For submission to: **RAN #8**
list expected approval meeting # here ↑

for approval
for information

strategic
non-strategic (for SMG use only)

Form: CR cover sheet, version 2 for 3GPP and SMG The latest version of this form is available from: <ftp://ftp.3gpp.org/Information/CR-Form-v2.doc>

Proposed change affects:
(at least one should be marked with an X)

(U)SIM ME UTRAN / Radio Core Network

Source:

RAN WG4

Date:

22.5.2000

Subject:

Relationship between RF generation and chip clock

Work item:

TS 25.142

Category:

(only one category shall be marked with an X)

F Correction
A Corresponds to a correction in an earlier release
B Addition of feature
C Functional modification of feature
D Editorial modification

Release:

Phase 2
Release 96
Release 97
Release 98
Release 99
Release 00

Reason for change:

Alignment with recent amendments incorporated into the core specification TS 25.105 via CR 031

Clauses affected:

5.4 – 5.14, 6.3.2

Other specs affected:

Other 3G core specifications → List of CRs:
Other GSM core specifications → List of CRs:
MS test specifications → List of CRs:
BSS test specifications → List of CRs:
O&M specifications → List of CRs:

Other comments:

5 General test conditions and declarations

The requirements of this clause apply to all tests in this TS, when applicable.

The general conditions during the tests should be according to the relevant parts of ETR 027 [2] (methods of measurement for mobile radio equipment) with the exceptions and additions defined in the individual tests.

Many of the tests in this TS measure a parameter relative to a value which is not fully specified in the UTRA specifications. For these tests, the conformance requirement is determined relative to a nominal value specified by the manufacturer.

Certain functions of a BS are optional in the UTRA specifications.

When specified in a test, the manufacturer shall declare the nominal value of a parameter, or whether an option is supported.

5.1 Base station classes

The requirements in this specification apply to base stations intended for general-purpose applications in co-ordinated network operation.

In future, further classes of base stations may be defined; the requirements for these may be different than for general-purpose applications.

5.2 Output power and determination of power class

The manufacturer shall declare the maximum output power of the base station which is defined as the mean power level per carrier at the antenna connector; see subclause 6.2.

5.3 Specified frequency range

The manufacturer shall declare:

- which of the frequency bands defined in sub-clause 4.2 is supported by the BS.
- the frequency range within the above frequency band(s) supported by the BS. As TDD is employed, the same frequency range is used for transmit and receive operation.

Many tests in this TS are performed with appropriate frequencies in the bottom, middle and top of the operating frequency band of the BS. These are denoted as RF channels B (bottom), M (middle) and T (top).

When a test is performed by a test laboratory, the UARFCNs to be used for RF channels B, M and T shall be specified by the laboratory. The laboratory may consult with operators, the manufacturer or other bodies.

When a test is performed by a manufacturer, the UARFCNs to be used for RF channels B, M and T may be specified by an operator.

5.4 Relationship between RF generation and chip clock

The manufacturer shall declare compliance with the requirement that the BS shall use the same frequency source for both RF generation and the chip clock.

5.45 Spectrum emission mask

The manufacturer shall declare whether the BS under test is intended to operate in regions where conformance to the spectrum emission mask defined in subclause 6.6.2.1.2 is mandatory. If so, the conformance test for spectrum emission mask specified in subclause 6.6.2.1 shall be performed; otherwise, this test is not required.

5.56 Adjacent Channel Leakage power Ratio (ACLR)

The manufacturer shall declare:

- whether the BS under test is intended to operate in proximity to another TDD BS or FDD BS operating on the first or second adjacent frequency. If so, conformance with the ACLR requirement specified in subclause 6.6.2.2.2 is mandatory; otherwise, this requirement needs not to be tested.
- whether the BS under test is intended to operate co-sited to another TDD BS or FDD BS operating on the first or second adjacent frequency. If so, conformance with the ACLR requirement specified in subclause 6.6.2.2.3 is mandatory; otherwise, this requirement needs not to be tested.

5.67 Tx spurious emissions

5.67.1 Category of spurious emissions limit

The manufacturer shall declare one of the following:

- a) the BS shall be tested against Category A limits for spurious emissions, as defined in ITU-R Recommendation SM.329-7 [6].

or

- b) the BS shall be tested against Category B limits for spurious emissions, as defined in ITU-R Recommendation SM.329-7 [6].

If the manufacturer declares Category A limits to be applicable, conformance with the spurious emissions requirements specified in subclause 6.6.3.2.1.1 is mandatory, and the requirements specified in subclause 6.6.3.2.1.2 need not to be tested. If the manufacturer declares Category B limits to be applicable, conformance with the spurious emissions requirements specified in subclause 6.6.3.2.1.2 is mandatory, and the requirements specified in subclause 6.6.3.2.1.1 need not to be tested.

5.67.2 Co-existence with GSM

The manufacturer shall declare:

- whether the BS under test is intended to operate in geographic areas in which also GSM 900 is deployed. If so, compliance with the conformance requirement specified in subclause 6.6.3.2.2.1 is mandatory; otherwise, this requirement needs not to be tested.
- whether the BS under test is intended to operate co-located with a GSM 900 BTS. If so, compliance with the conformance requirement specified in subclause 6.6.3.2.2.2 is mandatory; otherwise, this requirement needs not to be tested.

5.67.3 Co-existence with DCS 1800

The manufacturer shall declare:

- whether the BS under test is intended to operate in geographic areas in which also DCS 1800 is deployed. If so, compliance with the conformance requirement specified in subclause 6.6.3.2.3.1 is mandatory; otherwise, this requirement needs not to be tested.

- whether the BS under test is intended to operate co-located with a DCS 1800 BTS. If so, compliance with the conformance requirement specified in subclause 6.6.3.2.3.2 is mandatory; otherwise, this requirement needs not to be tested.

5.76.4 Co-existence with UTRA FDD

The manufacturer shall declare:

- whether the BS under test is intended to operate in geographic areas in which also UTRA FDD is deployed. If so, compliance with the conformance requirement specified in subclause 6.6.3.2.4.1 is mandatory; otherwise, this requirement needs not to be tested.
- whether the BS under test is intended to operate co-located with a UTRA FDD BS. If so, compliance with the conformance requirement specified in subclause 6.6.3.2.4.2 is mandatory; otherwise, this requirement needs not to be tested.

5.78 Blocking characteristics

The conformance requirements with respect to the parameter blocking characteristics are dependent on the operating frequency bands of the BS under test; see subclause 7.5.2. However, no additional declaration is required; the need for a manufacturer's declaration of the frequency bands supported by the BS is already covered by subclause 5.3

If the manufacturer has declared that the BS supports the frequency bands defined in subclause 4.2 a), compliance with the conformance requirements specified in table 7.5.2.1 is mandatory. If the manufacturer has declared that the BS supports the frequency bands defined in subclause 4.2 b) or 4.2 c), compliance with the conformance requirements specified in table 7.5.2.2 is mandatory.

5.89 Test environments

For each test in this TS, the environmental conditions under which the BS is to be tested are defined.

5.89.1 Normal test environment

When a normal test environment is specified for a test, the test should be performed under any combination of conditions between the minimum and maximum limits stated in table 5.89.1.1.

Table 5.89.1.1: Limits of conditions for Normal Test Environment

Condition	Minimum	Maximum
Barometric pressure	86 kPa	106 kPa
Temperature	15°C	30°C
Relative Humidity	20 %	85 %
Power supply	Nominal, as declared by the manufacturer	
Vibration	Negligible	

The ranges of barometric pressure, temperature and humidity represent the maximum variation expected in the uncontrolled environment of a test laboratory. If it is not possible to maintain these parameters within the specified limits, the actual values shall be recorded in the test report.

NOTE: This may, for instance, be the case for measurements of radiated emissions performed on an open field test site.

5.89.2 Extreme test environment

The manufacturer shall declare one of the following:

- a) The equipment class for the equipment under test, as defined in ETS 300 019-1-3, (Equipment Engineering (EE); Environmental conditions and environmental test for telecommunications equipment, Part 1-3: Classification of environmental conditions, Stationary use at weather protected locations).
- b) The equipment class for the equipment under test, as defined in ETS 300 019-1-4, (Equipment Engineering (EE); Environmental conditions and environmental test for telecommunications equipment, Part 1-4: Classification of environmental conditions, Stationary use at non-weather protected locations).
- c) For equipment that does not comply to an ETS 300 019-1 [8] class, the relevant classes from IEC 721 [3] documentation for Temperature, Humidity and Vibration shall be declared.

NOTE: Reduced functionality for conditions that fall out side of the standard operational conditions are not tested in this TS. These may be stated and tested separately.

5.89.2.1 Extreme temperature

When an extreme temperature test environment is specified for a test, the test shall be performed at the standard minimum and maximum operating temperatures defined by the manufacturer's declaration for the equipment under test.

Minimum temperature:

The test shall be performed with the environmental test equipment and methods of inducing the required environmental phenomena into the equipment, conforming to the test procedure of IEC 68-2-1 [4], Environmental Testing, Part 2: Tests - Tests A: Cold. The equipment shall be maintained at the stabilized condition for the duration of the test sequence.

Maximum temperature:

The test shall be performed with the environmental test equipment and methods of inducing the required environmental phenomena in to the equipment, conforming to the test procedure of IEC 68-2-2 [4] (Environmental Testing, Part 2: Tests - Tests Bd Dry heat). The equipment shall be maintained at the stabilized condition for the duration of the test sequence.

NOTE: It is recommended that the equipment is made fully operational prior to the equipment being taken to its lower operating temperature.

5.89.3 Vibration

When vibration conditions are specified for a test, the test shall be performed while the equipment is subjected to a vibration sequence as defined by the manufacturers declaration for the equipment under test. This shall use the environmental test equipment and methods of inducing the required environmental phenomena in to the equipment, conforming to the test procedure of IEC 68-2-6 [4], Environmental Testing, Part 2: Tests - Test Fc and guidance: Vibration (Sinusoidal). Other environmental conditions shall be within the ranges specified in subclause 5.49.1, Normal test environment.

NOTE: The higher levels of vibration may induce undue physical stress in to equipment after a prolonged series of tests. The testing body should only vibrate the equipment during the RF measurement process.

5.89.4 Power supply

When extreme power supply conditions are specified for a test, the test shall be performed at the standard upper and lower limits of operating voltage defined by the manufacturer's declaration for the equipment under test.

Upper voltage limit

The equipment shall be supplied with a voltage equal to the upper limit declared by the manufacturer (as measured at the input terminals to the equipment). The tests shall be carried out at a steady state minimum and maximum limit declared by the manufacturer for the equipment, to the methods described in IEC 68-2-1 [4] Test Ab/Ad: Cold and IEC 68-2-2 Test Bb/Bd: Dry Heat.

Lower voltage limit

The equipment shall be supplied with a voltage equal to the lower limit declared by the manufacturer (as measured at the input terminals to the equipment). The tests shall be carried out at a steady state minimum and maximum limit declared by the manufacturer for the equipment, to the methods described in IEC 68-2-1 [4] Test Ab/Ad: Cold and IEC 68-2-2 [4] Test Bb/Bd: Dry Heat.

5.89.5 Acceptable uncertainty of measurement equipment

The maximum acceptable uncertainty of measurement equipment is specified separately for each test, where appropriate. The measurement equipment shall enable the stimulus signals in the test case to be adjusted to within the specified tolerance, and the conformance requirement to be measured with an uncertainty not exceeding the specified values. All tolerances and uncertainties are absolute values, unless otherwise stated.

Subclause 5.89, Test environments:

Pressure	± 5 kPa
Temperature	± 2 degrees
Relative Humidity	± 5 %
DC Voltage	$\pm 1,0$ %
AC Voltage	$\pm 1,5$ %
Vibration	10 %
Vibration frequency	0,1 Hz

The above values shall apply unless the test environment is controlled and the specification for the control of the test environment specifies the uncertainty for the parameter.

Transmitter

Subclause 6.2, Base station maximum output power:

Conformance requirement:

RF power, for static power step 0 $\pm 1,0$ dB

Subclause 6.3, Frequency stability:

Conformance requirement:

Frequency ± 10 Hz

Subclause 6.4, Output power dynamics

Conformance requirement:

RF power, for static power steps (minimum and maximum Tx power) $\pm 1,0$ dB

Relative RF Power $\pm 0,7$ dB

Subclause 6.5, Transmit OFF power:

Conformance requirement:

RF power difference

Power difference < 50 dB $\pm 0,7$ dB

Power difference ≥ 50 dB $\pm 1,5$ dB

Subclause 6.6, Output RF spectrum emissions

Conformance requirement:

RF power difference

Power difference < 50 dB $\pm 0,7$ dB

Power difference ≥ 50 dB $\pm 1,5$ dB

Relative RF power:

Table 5.89.5.1: Acceptable uncertainty of relative RF power measurements

Offset from carrier, MHz	Power difference, dB	Uncertainty of relative power, dB

Spurious emissions

RF power

- inside the BS transmit band ± 1.5 dB

- outside the BS transmit band:

$f \leq 2$ GHz ± 1.5 dB

2 GHz < $f \leq 4$ GHz ± 2.0 dB

$f > 4$ GHz ± 4.0 dB

Subclause 6.7, Transmit intermodulation:

Test case:

Relative RF power (of injected signal) ± 1.5 dB

Conformance requirement (outside RX band):

RF power; absolute limit values ± 1.5 dB

RF power, relative measurements ± 2.0 dB

Conformance requirement (inside RX band):

RF power; absolute limit values $+4$ dB -3 dB

NOTE: The positive limit for uncertainty is greater than the negative limit because the measurement result can be increased (but not decreased) due to intermodulation products within the measurement apparatus.

Receiver

Where a measurement uncertainty of $+5$ dB -0 dB is specified for an input signal, the measured value of the input signal should be increased by an amount equal to the uncertainty with which it can be measured. This will ensure that the true value of the input signal is not below the specified nominal.

Subclause 7.2, Reference sensitivity level

Test case:

RF power ± 1.0 dB

Subclause 7.3, Dynamic range:

Test case:

RF power ± 1.5 dB

Relative RF power ± 3.0 dB

Subclause 7.4, Adjacent Channel Selectivity (ACS):

Test case:

RF power ± 1.5 dB

Relative RF power ± 3.0 dB

Subclause 7.5, Blocking characteristics:

Test case:

RF power, wanted signal ± 1.0 dB

RF power, interfering signal;

$f \leq 2$ GHz ± 0.7 dB

2 GHz $< f \leq 4$ GHz ± 1.5 dB

$f > 4$ GHz ± 3.0 dB

Subclause 7.6, Intermodulation characteristics:

Test case:

RF power, wanted signal	± 1.0 dB
RF power, interfering signals	± 0.7 dB

Subclause 7.7, Spurious emissions:

Conformance requirement:

RF power;

$f \leq 2$ GHz	± 1.5 dB
2 GHz $< f \leq 4$ GHz	± 2.0 dB
$f > 4$ GHz	± 4.0 dB

5.910 Interpretation of measurement results

The requirements given in these specifications are absolute. Compliance with the requirement is determined by comparing the measured value with the specified limit, without making allowance for measurement uncertainty.

The measurement uncertainty for the measurement of each parameter shall be included in the test report.

The recorded value for the measurement uncertainty shall be, for each measurement, equal to or lower than the appropriate figure in subclause 5.89 of this TS.

NOTE: This procedure is recommended in ETR 028 [5].

If the measurement apparatus for a test is known to have a measurement uncertainty greater than that specified in subclause 5.89, it is still permitted to use this apparatus provided that an adjustment is made to the measured value as follows:

The adjustment is made by subtracting the modulus of the specified measurement uncertainty in subclause 4.7 from the measurement uncertainty of the apparatus. The measured value is then increased or decreased by the result of the subtraction, whichever is most unfavourable in relation to the limit.

5.101 Selection of configurations for testing

Most tests in this TS are only performed for a subset of the possible combinations of test conditions. For instance:

- Not all TRXs in the configuration may be specified to be tested.
- Only one RF channel may be specified to be tested.
- Only one timeslot may be specified to be tested.

When a test is performed by a test laboratory, the choice of which combinations are to be tested shall be specified by the laboratory. The laboratory may consult with operators, the manufacturer or other bodies.

When a test is performed by a manufacturer, the choice of which combinations are to be tested may be specified by an operator.

5.142 BS Configurations

This TS has been written to specify tests for the standard configurations of BS which have been assumed in UTRA requirements specifications, in particular TS 25.105 "UTRA (BS) TDD; Radio transmission and Reception" [1]. However, there are other configurations of BS which comply with these specifications, but for which the application of these specifications is not fully defined. For some such configurations there may be alternate ways to apply the

requirements of this specification to testing of the configuration, or some variation in the test method may be necessary. It may therefore be necessary for the parties to the testing to reach agreement over the method of testing in advance.

If the BS is supplied in a number of different environmental enclosures or configurations, it may not be necessary to test RF parameters for each environmental configuration, provided that it can be demonstrated that the equipment has been tested at the worst internal environmental conditions.

Where alternative interpretations of this specification are possible for a BS configuration under test, the interpretation which has been adopted in performing the test shall be recorded with the test results.

Where variation in the test method within this TS has been necessary to enable a BS configuration to be tested, the variation in the test method which has been made in performing the test shall be recorded with the test results. Where possible, agreement should be reached in advance about the nature of such a variation with any party who will later receive the test results.

Possible interpretations of this TS for some common configurations are given in the following subclauses.

5.142.1 Receiver diversity

For the tests in clause 7 of this TS, the specified test signals shall be applied to one receiver antenna connector, with the remaining receiver antenna connectors being terminated with 50 ohms.

5.142.2 Duplexers

Due to TDD operation, there is no need to use a duplexer in the BS.

5.142.3 Power supply options

If the BS is supplied with a number of different power supply configurations, it may not be necessary to test RF parameters for each of the power supply options, provided that it can be demonstrated that the range of conditions over which the equipment is tested is at least as great as the range of conditions due to any of the power supply configurations.

This applies particularly if a BS contains a DC rail which can be supplied either externally or from an internal mains power supply. In this case, the conditions of extreme power supply for the mains power supply options can be tested by testing only the external DC supply option. The range of DC input voltages for the test should be sufficient to verify the performance with any of the power supplies, over its range of operating conditions within the BS, including variation of mains input voltage, temperature and output current.

5.142.4 Ancillary RF amplifiers

Ancillary RF amplifier: a piece of equipment, which when connected by RF coaxial cables to the BS, has the primary function to provide amplification between the transmit and/or receive antenna connector of a BS and an antenna without requiring any control signal to fulfil its amplifying function.

The requirements of this TS shall be met with the ancillary RF amplifier fitted. At tests according to clause 6 and 7 for TX and RX respectively, the ancillary amplifier is connected to the BS by a connecting network (including any cable(s), attenuator(s), etc.) with applicable loss to make sure the appropriate operating conditions of the ancillary amplifier and the BS. The applicable connecting network loss range is declared by the manufacturer. Other characteristics and the temperature dependence of the attenuation of the connecting network are neglected. The actual attenuation value of the connecting network is chosen for each test as one of the applicable extreme values. The lowest value is used unless otherwise stated.

Sufficient tests should be repeated with the ancillary amplifier fitted and, if it is optional, without the ancillary RF amplifier to verify that the BS meets the requirements of this TS in both cases.

5.142.5 BS using antenna arrays

A BS may be configured with a multiple antenna port connection for some or all of its TRXs or with an antenna array related to one cell (not one array per TRX). This subclause applies to a BS which meets at least one of the following conditions:

- The transmitter output signals from one or more TRX appear at more than one antenna port, or
- there is more than one receiver antenna port for a TRX or per cell and an input signal is required at more than one port for the correct operation of the receiver (NOTE: diversity reception does not meet this requirement) thus the outputs from the transmitters as well as the inputs to the receivers are directly connected to several antennas (known as "aircombining"), or
- transmitters and receivers are connected via duplexers to more than one antenna

If a BS is used, in normal operation, in conjunction with an antenna system which contains filters or active elements which are necessary to meet the UTRA requirements, the tests of conformance may be performed on a system comprising the BS together with these elements, supplied separately for the purposes of testing. In this case, it must be demonstrated that the performance of the configuration under test is representative of the system in normal operation, and the conformance assessment is only applicable when the BS is used with the antenna system.

For testing of conformance of such a BS, the following procedure may be used:

Receiver tests

For each test, the test signals applied to the receiver antenna connectors shall be such that the sum of the powers of the signals applied equals the power of the test signal(s) specified in the test.

An example of a suitable test configuration is shown in figure 5.142.5.1.

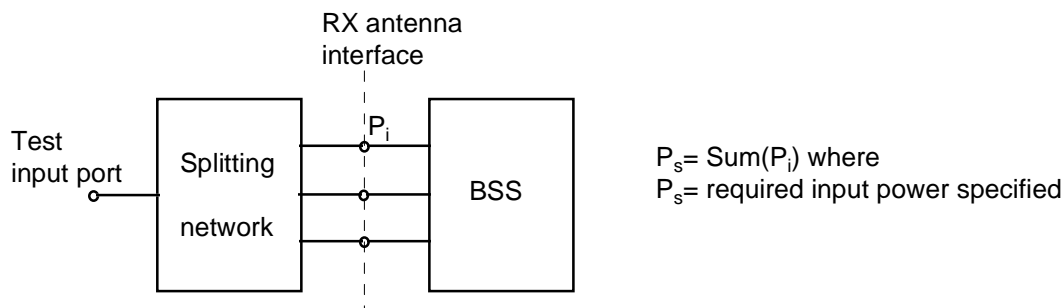

Figure 5.142.5.1: Receiver test setup

For spurious emissions from the receiver antenna connector, the test may be performed separately for each receiver antenna connector.

Transmitter tests

For each test, the conformance requirement shall be met by the sum of the signals emitted by each transmitter antenna connector. This may be assessed by separately measuring the signals emitted by each antenna connector and summing the results, or by combining the signals and performing a single measurement. The characteristics (e.g. amplitude and phase) of the combining network should be such that the power of the combined signal is maximised.

An example of a suitable test configuration is shown in figure 5.142.5.2.

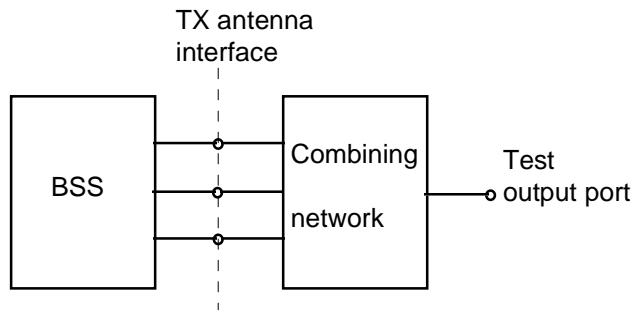

Figure 5.142.5.2: Transmitter test setup

For Intermodulation attenuation, the test may be performed separately for each transmitter antenna connector.

5.123 Overview of the conformance test requirements

Tables 5.123.1, 5.123.2 and 5.123.3 give an overview of the conformance test requirements for the transmitter, the receiver and system performance, respectively.

Table 5.123.1: Overview of the conformance tests requirements for the transmitter

Parameter	Subclause	Note
Maximum output power	6.2	manufacturer's declaration required
Frequency stability	6.3	manufacturer's declaration required
Output power dynamics	6.4	
Inner loop power control	6.4.1	
Power control steps	6.4.2	
Power control dynamic range	6.4.3	
Minimum transmit power	6.4.4	
Primary CCPCH power	6.4.5.	
Transmit OFF power	6.5	
Output RF spectrum emissions	6.6	
Occupied bandwidth	6.6.1	
Out-of-band emission	6.6.2	
Spectrum emission mask	6.6.2.1	manufacturer's declaration required
Adjacent Channel Leakage power Ratio (ACLR)	6.6.2.2	manufacturer's declaration required
Spurious emissions	6.6.3	
Mandatory requirements	6.6.3.2.1	manufacturer's declaration required
Co-existence with GSM 900	6.6.3.2.2	manufacturer's declaration required
Co-existence with DCS 1800	6.6.3.2.3	manufacturer's declaration required
Co-existence with UTRA FDD	6.6.3.2.4	manufacturer's declaration required
Transmit intermodulation	6.7	
Transmit modulation	6.8	
Modulation accuracy	6.8.1	
Peak code domain error	6.8.2	

Table 5.123.2: Overview of the conformance tests requirements for the receiver

Parameter	Subclause	Note
Reference sensitivity level	7.2	
Dynamic range	7.3	
Adjacent Channel Selectivity (ACS)	7.4	
Blocking characteristics	7.5	manufacturer's declaration required
Intermodulation characteristics	7.6	
Spurious emissions	7.7	

Table 5.123.3: Overview of the conformance test requirements for system performance

Parameter	Subclause	Note
Demodulation in static propagation conditions	8.2	
Demodulation of DCH	8.2.1	
Demodulation of DCH in multipath fading conditions	8.3	
Multipath fading Case 1	8.3.1	
Multipath fading Case 2	8.3.2	
Multipath fading Case 3	8.3.3	

5.134 Format and interpretation of tests

Each test in the following clauses has a standard format:

X Title

The title gives the name of the parameter to be tested.

X.1 Definition and applicability

This subclause gives the general definition of the parameter under consideration and specifies whether the test is applicable to all equipment or to a certain subset only.

X.2 Conformance requirements

This subclause describes the requirements the equipment under test has to fulfil to ensure compliance with the relevant specification.

In addition, this subclause contains the reference to the subclause to the 3GPP reference (or core) specification from which the conformance requirements are derived.

X.3 Test purpose

This subclause defines the purpose of the test.

X.4 Method of test

X.4.1 Initial conditions

This subclause defines the initial conditions for each test, including the basic measurement setup.

X.4.2 Procedure

This subclause describes the steps necessary to perform the test and provides further details of the test definition like point of access (e.g. antenna port), domain (e.g. frequency-span), range, weighting (e.g. bandwidth), and algorithms (e.g. averaging).

X.5 Test requirements

This subclause defines the pass/fail criteria for the equipment under test.

6.3 Frequency stability

6.3.1 Definition and applicability

Frequency stability is the ability of the BS to transmit at the assigned carrier frequency.

The requirements in this subclause shall apply to base stations intended for general-purpose applications.

6.3.2 Conformance requirements

The BS frequency stability shall be within $\pm 0,05$ ppm.

The reference for this requirement is TS 25.105 subclause 6.3.1.

TS 25.105 subclause 6.3 specifies the additional requirement that the BS shall use the same frequency source for both RF generation and the chip clock. Compliance with this requirement is demonstrated by manufacturer's declaration; see subclause 5.4; a dedicated conformance test for this requirement is not defined.

6.3.3 Test purpose

The test purpose is to verify the accuracy of the carrier frequency across the frequency range and under normal and extreme conditions.

6.3.4 Method of test

6.3.4.1 Initial conditions

- (1) The transmitter under test and all other transmitters of the base station (if any) are switched on.
- (2) The power of the transmitters not under test (if any) are controlled down.
- (3) Connect the tester to the BS antenna connector.
- (4) Set the parameters of the transmitted signal according to table 6.3.4.1.1.

Table 6.3.4.1.1: Parameters of the transmitted signal for frequency stability test

Parameter	Value/description
TDD Duty Cycle	TS i ; $i = 0, 1, 2, \dots, 14$: transmit, if i is even; receive, if i is odd.
Number of DPCH in each active TS	1
Base Station output power	maximum, according to manufacturer's declaration
Data content of DPCH	real life (sufficient irregular)

6.3.4.2 Procedure

- (1) Measure the frequency error Δf across one burst (time slot), by applying the global in-channel Tx test method described in Annex C.
- (2) Repeat step (1) for 200 bursts (time slots).
- (3) Run steps (1) and (2) for RF channels Low / Mid / High.

6.3.5 Test requirements

For all measured bursts (time slots), the frequency error, derived according to subclause 6.3.4.2, shall not exceed $0,5 \times 10E-7$.

CHANGE REQUEST

Please see embedded help file at the bottom of this page for instructions on how to fill in this form correctly.

25.142

CR 021

Current Version: 3.1.0

GSM (AA.BB) or 3G (AA.BBB) specification number ↑

↑ CR number as allocated by MCC support team

For submission to: RAN #8

list expected approval meeting # here ↑

for approval
for information

strategic
non-strategic (for SMG use only)

Form: CR cover sheet, version 2 for 3GPP and SMG

The latest version of this form is available from: <ftp://ftp.3gpp.org/Information/CR-Form-v2.doc>

Proposed change affects:

(at least one should be marked with an X)

(U)SIM

ME

UTRAN / Radio

Core Network

Source:

RAN WG4

Date:

05/05/00

Subject:

Modification to the handling of BS TDD Measurement Uncertainty

Work item:

UTRA

Category:

(only one category shall be marked with an X)

- F Correction
A Corresponds to a correction in an earlier release
B Addition of feature
C Functional modification of feature
D Editorial modification

Release:

- Phase 2
Release 96
Release 97
Release 98
Release 99
Release 00

Reason for change:

A confidence level of 95% for measurement tolerances and uncertainties has to be included. The chapter for the interpretation of measurement results has to be revised in harmonizing with the core specifications.

Clauses affected:

5.8.5, 5.9

Other specs affected:

- Other 3G core specifications → List of CRs:
Other GSM core specifications → List of CRs:
MS test specifications → List of CRs:
BSS test specifications → List of CRs:
O&M specifications → List of CRs:

Other comments:

5.8.2.1 Extreme temperature

When an extreme temperature test environment is specified for a test, the test shall be performed at the standard minimum and maximum operating temperatures defined by the manufacturer's declaration for the equipment under test.

Minimum temperature:

The test shall be performed with the environmental test equipment and methods of inducing the required environmental phenomena into the equipment, conforming to the test procedure of IEC 68-2-1 [4], Environmental Testing, Part 2: Tests - Tests A: Cold. The equipment shall be maintained at the stabilized condition for the duration of the test sequence.

Maximum temperature:

The test shall be performed with the environmental test equipment and methods of inducing the required environmental phenomena in to the equipment, conforming to the test procedure of IEC 68-2-2 [4] (Environmental Testing, Part 2: Tests - Tests Bd Dry heat). The equipment shall be maintained at the stabilized condition for the duration of the test sequence.

NOTE: It is recommended that the equipment is made fully operational prior to the equipment being taken to its lower operating temperature.

5.8.3 Vibration

When vibration conditions are specified for a test, the test shall be performed while the equipment is subjected to a vibration sequence as defined by the manufacturers declaration for the equipment under test. This shall use the environmental test equipment and methods of inducing the required environmental phenomena in to the equipment, conforming to the test procedure of IEC 68-2-6 [4], Environmental Testing, Part 2: Tests - Test Fc and guidance: Vibration (Sinusoidal). Other environmental conditions shall be within the ranges specified in subclause 5.4.1, Normal test environment.

NOTE: The higher levels of vibration may induce undue physical stress in to equipment after a prolonged series of tests. The testing body should only vibrate the equipment during the RF measurement process.

5.8.4 Power supply

When extreme power supply conditions are specified for a test, the test shall be performed at the standard upper and lower limits of operating voltage defined by the manufacturer's declaration for the equipment under test.

Upper voltage limit

The equipment shall be supplied with a voltage equal to the upper limit declared by the manufacturer (as measured at the input terminals to the equipment). The tests shall be carried out at a steady state minimum and maximum limit declared by the manufacturer for the equipment, to the methods described in IEC 68-2-1 [4] Test Ab/Ad: Cold and IEC 68-2-2 Test Bb/Bd: Dry Heat.

Lower voltage limit

The equipment shall be supplied with a voltage equal to the lower limit declared by the manufacturer (as measured at the input terminals to the equipment). The tests shall be carried out at a steady state minimum and maximum limit declared by the manufacturer for the equipment, to the methods described in IEC 68-2-1 [4] Test Ab/Ad: Cold and IEC 68-2-2 [4] Test Bb/Bd: Dry Heat.

5.8.5 Acceptable uncertainty of measurement equipment

The maximum acceptable uncertainty of measurement equipment is specified separately for each test, where appropriate. The measurement equipment shall enable the stimulus signals in the test case to be adjusted to within the specified tolerance, and the conformance requirement to be measured with an uncertainty not exceeding the specified values. All tolerances and uncertainties are absolute values, [and are valid for a confidence level of 95 %](#), unless otherwise stated.

It should be noted that the stated uncertainties in subclause 4.1 apply to the test equipment only and do not include system effects due to mismatch between the DUT and the test equipment.

Subclause 5.8, Test environments:

Pressure	± 5 kPa
Temperature	± 2 degrees
Relative Humidity	± 5 %
DC Voltage	$\pm 1,0$ %
AC Voltage	$\pm 1,5$ %
Vibration	10 %
Vibration frequency	0,1 Hz

The above values shall apply unless the test environment is controlled and the specification for the control of the test environment specifies the uncertainty for the parameter.

Transmitter

Subclause 6.2, Base station maximum output power:

Conformance requirement:

RF power, for static power step 0 $\pm 1,0$ dB

Subclause 6.3, Frequency stability:

Conformance requirement:

Frequency ± 10 Hz

Subclause 6.4, Output power dynamics

Conformance requirement:

RF power, for static power steps (minimum and maximum Tx power) $\pm 1,0$ dB

Relative RF Power $\pm 0,7$ dB

Subclause 6.5, Transmit OFF power:

Conformance requirement:

RF power difference

Power difference < 50 dB $\pm 0,7$ dB

Power difference ≥ 50 dB $\pm 1,5$ dB

Subclause 6.6, Output RF spectrum emissions

Conformance requirement:

RF power difference

Subclause 7.3, Dynamic range:

Test case:

RF power	± 1.5 dB
Relative RF power	± 3.0 dB

Subclause 7.4, Adjacent Channel Selectivity (ACS):

Test case:

RF power	± 1.5 dB
Relative RF power	± 3.0 dB

Subclause 7.5, Blocking characteristics:

Test case:

RF power, wanted signal	± 1.0 dB
RF power, interfering signal;	
$f \leq 2$ GHz	± 0.7 dB
$2 \text{ GHz} < f \leq 4 \text{ GHz}$	± 1.5 dB
$f > 4 \text{ GHz}$	± 3.0 dB

Subclause 7.6, Intermodulation characteristics:

Test case:

RF power, wanted signal	± 1.0 dB
RF power, interfering signals	± 0.7 dB

Subclause 7.7, Spurious emissions:

Conformance requirement:

RF power;	
$f \leq 2$ GHz	± 1.5 dB
$2 \text{ GHz} < f \leq 4 \text{ GHz}$	± 2.0 dB
$f > 4 \text{ GHz}$	± 4.0 dB

5.9 Interpretation of measurement results

~~The requirements given in these specifications are absolute.~~ Compliance with the requirement is determined by comparing the measured value (or derived value from the measured one) with the specified test limit, without making allowance for measurement uncertainty. The test limit shall be relaxed from the specified limit in the core requirement using the maximum allowed uncertainty for the test equipment as specified in subclause 5.8.5.

The actual measurement uncertainty of the test equipment for the measurement of each parameter shall be included in the test report.

The recorded value for the ~~test equipment measurement~~ uncertainty shall be, for each measurement, equal to or lower than the appropriate figure in subclause 5.8.5 of this TS.

~~NOTE: This procedure is recommended in ETR 028 [5].~~

If the ~~measurement apparatus~~ test equipment for a test is known to have a measurement uncertainty greater than that specified in subclause 5.8.5, it is still permitted to use this ~~apparatus~~ equipment provided that an adjustment is made to the measured value as follows:

~~The adjustment is made by subtracting the modulus of the specified measurement uncertainty in subclause 4.7 from the measurement uncertainty of the apparatus. The measured value is then increased or decreased by the result of the subtraction, whichever is most unfavourable in relation to the limit.~~

The initial test limit is derived as above by relaxing the specified limit using the maximum allowed test equipment uncertainty as specified in subclause 5.8.5. Any additional uncertainty in the test equipment over and above that specified in subclause 5.8.5 shall be used to tighten the test limit. This procedure will ensure that test equipment not compliant with subclause 5.8.5 does not increase the chance of passing a device under test where that device would otherwise have failed the test if test equipment compliant with subclause 5.8.5 had been used.

5.10 Selection of configurations for testing

Most tests in this TS are only performed for a subset of the possible combinations of test conditions. For instance:

- Not all TRXs in the configuration may be specified to be tested.
- Only one RF channel may be specified to be tested.
- Only one timeslot may be specified to be tested.

When a test is performed by a test laboratory, the choice of which combinations are to be tested shall be specified by the laboratory. The laboratory may consult with operators, the manufacturer or other bodies.

When a test is performed by a manufacturer, the choice of which combinations are to be tested may be specified by an operator.

5.11 BS Configurations

This TS has been written to specify tests for the standard configurations of BS which have been assumed in UTRA requirements specifications, in particular TS 25.105 " UTRA (BS) TDD; Radio transmission and Reception " [1]. However, there are other configurations of BS which comply with these specifications, but for which the application of these specifications is not fully defined. For some such configurations there may be alternate ways to apply the requirements of this specification to testing of the configuration, or some variation in the test method may be necessary. It may therefore be necessary for the parties to the testing to reach agreement over the method of testing in advance.

If the BS is supplied in a number of different environmental enclosures or configurations, it may not be necessary to test RF parameters for each environmental configuration, provided that it can be demonstrated that the equipment has been tested at the worst internal environmental conditions.

Where alternative interpretations of this specification are possible for a BS configuration under test, the interpretation which has been adopted in performing the test shall be recorded with the test results.

Where variation in the test method within this TS has been necessary to enable a BS configuration to be tested, the variation in the test method which has been made in performing the test shall be recorded with the test results. Where possible, agreement should be reached in advance about the nature of such a variation with any party who will later receive the test results.

Possible interpretations of this TS for some common configurations are given in the following subclauses.

CHANGE REQUEST

Please see embedded help file at the bottom of this page for instructions on how to fill in this form correctly.

25.142 CR 022

Current Version: **3.1.0**

GSM (AA.BB) or 3G (AA.BBB) specification number ↑

↑ CR number as allocated by MCC support team

For submission to:
list expected approval meeting # here
↑

for approval
for information

strategic
non-strategic (for SMG use only)

Form: CR cover sheet, version 2 for 3GPP and SMG The latest version of this form is available from: <ftp://ftp.3gpp.org/Information/CR-Form-v2.doc>

Proposed change affects:

(at least one should be marked with an X)

(U)SIM ME UTRAN / Radio Core Network

Source:

RAN WG4

Date:

23.05.20000

Subject:

Clarification of the specification on Peak Code Domain Error (PCDE)

Work item:

TS 25.142

Category:

(only one category shall be marked with an X)

F Correction
A Corresponds to a correction in an earlier release
B Addition of feature
C Functional modification of feature
D Editorial modification

Release:

Phase 2
Release 96
Release 97
Release 98
Release 99
Release 00

Reason for change:

The PCDE is strongly dependent on the spreading factor (SF); therefore, it is needed to clearly specify at which SF the PCDE is evaluated.

Clauses affected:

Other specs affected:

Other 3G core specifications → List of CRs:
Other GSM core specifications → List of CRs:
MS test specifications → List of CRs:
BSS test specifications → List of CRs:
O&M specifications → List of CRs:

Other comments:

6.8.2 Peak code domain error

6.8.2.1 Definition and applicability

The code domain error is computed by projecting the error vector power onto the code domain at ~~a specific~~
~~maximum~~ spreading factor. The error power for each code is defined as the ratio to the mean power of the reference waveform expressed in dB. And the Peak Code Domain Error is defined as the maximum value for Code Domain Error. The measurement interval is one timeslot.

The requirements in this subclause shall apply to base stations intended for general-purpose applications.

6.8.2.2 Conformance requirements

The peak code domain error shall not exceed -28 dB at spreading factor 16.

The reference for this requirement is TS 25.105 subclause 6.8.3.1.

CHANGE REQUEST

Please see embedded help file at the bottom of this page for instructions on how to fill in this form correctly.

25.142 CR 023

Current Version: **3.1.0**

GSM (AA.BB) or 3G (AA.BBB) specification number ↑

↑ CR number as allocated by MCC support team

For submission to: **RAN #8**
list expected approval meeting # here ↑

for approval
for information

strategic
non-strategic (for SMG use only)

Form: CR cover sheet, version 2 for 3GPP and SMG The latest version of this form is available from: <ftp://ftp.3gpp.org/Information/CR-Form-v2.doc>

Proposed change affects:
(at least one should be marked with an X)

(U)SIM ME UTRAN / Radio Core Network

Source:

RAN WG4

Date:

22.5.2000

Subject:

Relationship between RF generation and chip clock

Work item:

TS 25.142

Category:

(only one category shall be marked with an X)

F Correction
A Corresponds to a correction in an earlier release
B Addition of feature
C Functional modification of feature
D Editorial modification

Release:

Phase 2
Release 96
Release 97
Release 98
Release 99
Release 00

Reason for change:

Alignment with recent amendments incorporated into the core specification TS 25.105 via CR 031

Clauses affected:

5.4 – 5.14, 6.3.2

Other specs affected:

Other 3G core specifications → List of CRs:
Other GSM core specifications → List of CRs:
MS test specifications → List of CRs:
BSS test specifications → List of CRs:
O&M specifications → List of CRs:

Other comments:

5 General test conditions and declarations

The requirements of this clause apply to all tests in this TS, when applicable.

The general conditions during the tests should be according to the relevant parts of ETR 027 [2] (methods of measurement for mobile radio equipment) with the exceptions and additions defined in the individual tests.

Many of the tests in this TS measure a parameter relative to a value which is not fully specified in the UTRA specifications. For these tests, the conformance requirement is determined relative to a nominal value specified by the manufacturer.

Certain functions of a BS are optional in the UTRA specifications.

When specified in a test, the manufacturer shall declare the nominal value of a parameter, or whether an option is supported.

5.1 Base station classes

The requirements in this specification apply to base stations intended for general-purpose applications in co-ordinated network operation.

In future, further classes of base stations may be defined; the requirements for these may be different than for general-purpose applications.

5.2 Output power and determination of power class

The manufacturer shall declare the maximum output power of the base station which is defined as the mean power level per carrier at the antenna connector; see subclause 6.2.

5.3 Specified frequency range

The manufacturer shall declare:

- which of the frequency bands defined in sub-clause 4.2 is supported by the BS.
- the frequency range within the above frequency band(s) supported by the BS. As TDD is employed, the same frequency range is used for transmit and receive operation.

Many tests in this TS are performed with appropriate frequencies in the bottom, middle and top of the operating frequency band of the BS. These are denoted as RF channels B (bottom), M (middle) and T (top).

When a test is performed by a test laboratory, the UARFCNs to be used for RF channels B, M and T shall be specified by the laboratory. The laboratory may consult with operators, the manufacturer or other bodies.

When a test is performed by a manufacturer, the UARFCNs to be used for RF channels B, M and T may be specified by an operator.

5.4 Relationship between RF generation and chip clock

The manufacturer shall declare compliance with the requirement that the BS shall use the same frequency source for both RF generation and the chip clock.

5.45 Spectrum emission mask

The manufacturer shall declare whether the BS under test is intended to operate in regions where conformance to the spectrum emission mask defined in subclause 6.6.2.1.2 is mandatory. If so, the conformance test for spectrum emission mask specified in subclause 6.6.2.1 shall be performed; otherwise, this test is not required.

5.56 Adjacent Channel Leakage power Ratio (ACLR)

The manufacturer shall declare:

- whether the BS under test is intended to operate in proximity to another TDD BS or FDD BS operating on the first or second adjacent frequency. If so, conformance with the ACLR requirement specified in subclause 6.6.2.2.2 is mandatory; otherwise, this requirement needs not to be tested.
- whether the BS under test is intended to operate co-sited to another TDD BS or FDD BS operating on the first or second adjacent frequency. If so, conformance with the ACLR requirement specified in subclause 6.6.2.2.3 is mandatory; otherwise, this requirement needs not to be tested.

5.67 Tx spurious emissions

5.67.1 Category of spurious emissions limit

The manufacturer shall declare one of the following:

- a) the BS shall be tested against Category A limits for spurious emissions, as defined in ITU-R Recommendation SM.329-7 [6].

or

- b) the BS shall be tested against Category B limits for spurious emissions, as defined in ITU-R Recommendation SM.329-7 [6].

If the manufacturer declares Category A limits to be applicable, conformance with the spurious emissions requirements specified in subclause 6.6.3.2.1.1 is mandatory, and the requirements specified in subclause 6.6.3.2.1.2 need not to be tested. If the manufacturer declares Category B limits to be applicable, conformance with the spurious emissions requirements specified in subclause 6.6.3.2.1.2 is mandatory, and the requirements specified in subclause 6.6.3.2.1.1 need not to be tested.

5.67.2 Co-existence with GSM

The manufacturer shall declare:

- whether the BS under test is intended to operate in geographic areas in which also GSM 900 is deployed. If so, compliance with the conformance requirement specified in subclause 6.6.3.2.2.1 is mandatory; otherwise, this requirement needs not to be tested.
- whether the BS under test is intended to operate co-located with a GSM 900 BTS. If so, compliance with the conformance requirement specified in subclause 6.6.3.2.2.2 is mandatory; otherwise, this requirement needs not to be tested.

5.67.3 Co-existence with DCS 1800

The manufacturer shall declare:

- whether the BS under test is intended to operate in geographic areas in which also DCS 1800 is deployed. If so, compliance with the conformance requirement specified in subclause 6.6.3.2.3.1 is mandatory; otherwise, this requirement needs not to be tested.

- whether the BS under test is intended to operate co-located with a DCS 1800 BTS. If so, compliance with the conformance requirement specified in subclause 6.6.3.2.3.2 is mandatory; otherwise, this requirement needs not to be tested.

5.76.4 Co-existence with UTRA FDD

The manufacturer shall declare:

- whether the BS under test is intended to operate in geographic areas in which also UTRA FDD is deployed. If so, compliance with the conformance requirement specified in subclause 6.6.3.2.4.1 is mandatory; otherwise, this requirement needs not to be tested.
- whether the BS under test is intended to operate co-located with a UTRA FDD BS. If so, compliance with the conformance requirement specified in subclause 6.6.3.2.4.2 is mandatory; otherwise, this requirement needs not to be tested.

5.78 Blocking characteristics

The conformance requirements with respect to the parameter blocking characteristics are dependent on the operating frequency bands of the BS under test; see subclause 7.5.2. However, no additional declaration is required; the need for a manufacturer's declaration of the frequency bands supported by the BS is already covered by subclause 5.3

If the manufacturer has declared that the BS supports the frequency bands defined in subclause 4.2 a), compliance with the conformance requirements specified in table 7.5.2.1 is mandatory. If the manufacturer has declared that the BS supports the frequency bands defined in subclause 4.2 b) or 4.2 c), compliance with the conformance requirements specified in table 7.5.2.2 is mandatory.

5.89 Test environments

For each test in this TS, the environmental conditions under which the BS is to be tested are defined.

5.89.1 Normal test environment

When a normal test environment is specified for a test, the test should be performed under any combination of conditions between the minimum and maximum limits stated in table 5.89.1.1.

Table 5.89.1.1: Limits of conditions for Normal Test Environment

Condition	Minimum	Maximum
Barometric pressure	86 kPa	106 kPa
Temperature	15°C	30°C
Relative Humidity	20 %	85 %
Power supply	Nominal, as declared by the manufacturer	
Vibration	Negligible	

The ranges of barometric pressure, temperature and humidity represent the maximum variation expected in the uncontrolled environment of a test laboratory. If it is not possible to maintain these parameters within the specified limits, the actual values shall be recorded in the test report.

NOTE: This may, for instance, be the case for measurements of radiated emissions performed on an open field test site.

5.89.2 Extreme test environment

The manufacturer shall declare one of the following:

- a) The equipment class for the equipment under test, as defined in ETS 300 019-1-3, (Equipment Engineering (EE); Environmental conditions and environmental test for telecommunications equipment, Part 1-3: Classification of environmental conditions, Stationary use at weather protected locations).
- b) The equipment class for the equipment under test, as defined in ETS 300 019-1-4, (Equipment Engineering (EE); Environmental conditions and environmental test for telecommunications equipment, Part 1-4: Classification of environmental conditions, Stationary use at non-weather protected locations).
- c) For equipment that does not comply to an ETS 300 019-1 [8] class, the relevant classes from IEC 721 [3] documentation for Temperature, Humidity and Vibration shall be declared.

NOTE: Reduced functionality for conditions that fall out side of the standard operational conditions are not tested in this TS. These may be stated and tested separately.

5.89.2.1 Extreme temperature

When an extreme temperature test environment is specified for a test, the test shall be performed at the standard minimum and maximum operating temperatures defined by the manufacturer's declaration for the equipment under test.

Minimum temperature:

The test shall be performed with the environmental test equipment and methods of inducing the required environmental phenomena into the equipment, conforming to the test procedure of IEC 68-2-1 [4], Environmental Testing, Part 2: Tests - Tests A: Cold. The equipment shall be maintained at the stabilized condition for the duration of the test sequence.

Maximum temperature:

The test shall be performed with the environmental test equipment and methods of inducing the required environmental phenomena in to the equipment, conforming to the test procedure of IEC 68-2-2 [4] (Environmental Testing, Part 2: Tests - Tests Bd Dry heat). The equipment shall be maintained at the stabilized condition for the duration of the test sequence.

NOTE: It is recommended that the equipment is made fully operational prior to the equipment being taken to its lower operating temperature.

5.89.3 Vibration

When vibration conditions are specified for a test, the test shall be performed while the equipment is subjected to a vibration sequence as defined by the manufacturers declaration for the equipment under test. This shall use the environmental test equipment and methods of inducing the required environmental phenomena in to the equipment, conforming to the test procedure of IEC 68-2-6 [4], Environmental Testing, Part 2: Tests - Test Fc and guidance: Vibration (Sinusoidal). Other environmental conditions shall be within the ranges specified in subclause 5.49.1, Normal test environment.

NOTE: The higher levels of vibration may induce undue physical stress in to equipment after a prolonged series of tests. The testing body should only vibrate the equipment during the RF measurement process.

5.89.4 Power supply

When extreme power supply conditions are specified for a test, the test shall be performed at the standard upper and lower limits of operating voltage defined by the manufacturer's declaration for the equipment under test.

Upper voltage limit

The equipment shall be supplied with a voltage equal to the upper limit declared by the manufacturer (as measured at the input terminals to the equipment). The tests shall be carried out at a steady state minimum and maximum limit declared by the manufacturer for the equipment, to the methods described in IEC 68-2-1 [4] Test Ab/Ad: Cold and IEC 68-2-2 Test Bb/Bd: Dry Heat.

Lower voltage limit

The equipment shall be supplied with a voltage equal to the lower limit declared by the manufacturer (as measured at the input terminals to the equipment). The tests shall be carried out at a steady state minimum and maximum limit declared by the manufacturer for the equipment, to the methods described in IEC 68-2-1 [4] Test Ab/Ad: Cold and IEC 68-2-2 [4] Test Bb/Bd: Dry Heat.

5.89.5 Acceptable uncertainty of measurement equipment

The maximum acceptable uncertainty of measurement equipment is specified separately for each test, where appropriate. The measurement equipment shall enable the stimulus signals in the test case to be adjusted to within the specified tolerance, and the conformance requirement to be measured with an uncertainty not exceeding the specified values. All tolerances and uncertainties are absolute values, unless otherwise stated.

Subclause 5.89, Test environments:

Pressure	± 5 kPa
Temperature	± 2 degrees
Relative Humidity	± 5 %
DC Voltage	$\pm 1,0$ %
AC Voltage	$\pm 1,5$ %
Vibration	10 %
Vibration frequency	0,1 Hz

The above values shall apply unless the test environment is controlled and the specification for the control of the test environment specifies the uncertainty for the parameter.

Transmitter

Subclause 6.2, Base station maximum output power:

Conformance requirement:

RF power, for static power step 0 $\pm 1,0$ dB

Subclause 6.3, Frequency stability:

Conformance requirement:

Frequency ± 10 Hz

Subclause 6.4, Output power dynamics

Conformance requirement:

RF power, for static power steps (minimum and maximum Tx power) $\pm 1,0$ dB

Relative RF Power $\pm 0,7$ dB

Subclause 6.5, Transmit OFF power:

Conformance requirement:

RF power difference

Power difference < 50 dB $\pm 0,7$ dB

Power difference ≥ 50 dB $\pm 1,5$ dB

Subclause 6.6, Output RF spectrum emissions

Conformance requirement:

RF power difference

Power difference < 50 dB $\pm 0,7$ dB

Power difference ≥ 50 dB $\pm 1,5$ dB

Relative RF power:

Table 5.89.5.1: Acceptable uncertainty of relative RF power measurements

Offset from carrier, MHz	Power difference, dB	Uncertainty of relative power, dB

Spurious emissions

RF power

- inside the BS transmit band ± 1.5 dB

- outside the BS transmit band:

$f \leq 2$ GHz ± 1.5 dB

2 GHz < $f \leq 4$ GHz ± 2.0 dB

$f > 4$ GHz ± 4.0 dB

Subclause 6.7, Transmit intermodulation:

Test case:

Relative RF power (of injected signal) ± 1.5 dB

Conformance requirement (outside RX band):

RF power; absolute limit values ± 1.5 dB

RF power, relative measurements ± 2.0 dB

Conformance requirement (inside RX band):

RF power; absolute limit values $+4$ dB -3 dB

NOTE: The positive limit for uncertainty is greater than the negative limit because the measurement result can be increased (but not decreased) due to intermodulation products within the measurement apparatus.

Receiver

Where a measurement uncertainty of $+5$ dB -0 dB is specified for an input signal, the measured value of the input signal should be increased by an amount equal to the uncertainty with which it can be measured. This will ensure that the true value of the input signal is not below the specified nominal.

Subclause 7.2, Reference sensitivity level

Test case:

RF power ± 1.0 dB

Subclause 7.3, Dynamic range:

Test case:

RF power ± 1.5 dB

Relative RF power ± 3.0 dB

Subclause 7.4, Adjacent Channel Selectivity (ACS):

Test case:

RF power ± 1.5 dB

Relative RF power ± 3.0 dB

Subclause 7.5, Blocking characteristics:

Test case:

RF power, wanted signal ± 1.0 dB

RF power, interfering signal;

$f \leq 2$ GHz ± 0.7 dB

2 GHz $< f \leq 4$ GHz ± 1.5 dB

$f > 4$ GHz ± 3.0 dB

Subclause 7.6, Intermodulation characteristics:

Test case:

RF power, wanted signal	± 1.0 dB
RF power, interfering signals	± 0.7 dB

Subclause 7.7, Spurious emissions:

Conformance requirement:

RF power;

$f \leq 2$ GHz	± 1.5 dB
2 GHz $< f \leq 4$ GHz	± 2.0 dB
$f > 4$ GHz	± 4.0 dB

5.910 Interpretation of measurement results

The requirements given in these specifications are absolute. Compliance with the requirement is determined by comparing the measured value with the specified limit, without making allowance for measurement uncertainty.

The measurement uncertainty for the measurement of each parameter shall be included in the test report.

The recorded value for the measurement uncertainty shall be, for each measurement, equal to or lower than the appropriate figure in subclause 5.89 of this TS.

NOTE: This procedure is recommended in ETR 028 [5].

If the measurement apparatus for a test is known to have a measurement uncertainty greater than that specified in subclause 5.89, it is still permitted to use this apparatus provided that an adjustment is made to the measured value as follows:

The adjustment is made by subtracting the modulus of the specified measurement uncertainty in subclause 4.7 from the measurement uncertainty of the apparatus. The measured value is then increased or decreased by the result of the subtraction, whichever is most unfavourable in relation to the limit.

5.101 Selection of configurations for testing

Most tests in this TS are only performed for a subset of the possible combinations of test conditions. For instance:

- Not all TRXs in the configuration may be specified to be tested.
- Only one RF channel may be specified to be tested.
- Only one timeslot may be specified to be tested.

When a test is performed by a test laboratory, the choice of which combinations are to be tested shall be specified by the laboratory. The laboratory may consult with operators, the manufacturer or other bodies.

When a test is performed by a manufacturer, the choice of which combinations are to be tested may be specified by an operator.

5.142 BS Configurations

This TS has been written to specify tests for the standard configurations of BS which have been assumed in UTRA requirements specifications, in particular TS 25.105 "UTRA (BS) TDD; Radio transmission and Reception" [1]. However, there are other configurations of BS which comply with these specifications, but for which the application of these specifications is not fully defined. For some such configurations there may be alternate ways to apply the

requirements of this specification to testing of the configuration, or some variation in the test method may be necessary. It may therefore be necessary for the parties to the testing to reach agreement over the method of testing in advance.

If the BS is supplied in a number of different environmental enclosures or configurations, it may not be necessary to test RF parameters for each environmental configuration, provided that it can be demonstrated that the equipment has been tested at the worst internal environmental conditions.

Where alternative interpretations of this specification are possible for a BS configuration under test, the interpretation which has been adopted in performing the test shall be recorded with the test results.

Where variation in the test method within this TS has been necessary to enable a BS configuration to be tested, the variation in the test method which has been made in performing the test shall be recorded with the test results. Where possible, agreement should be reached in advance about the nature of such a variation with any party who will later receive the test results.

Possible interpretations of this TS for some common configurations are given in the following subclauses.

5.142.1 Receiver diversity

For the tests in clause 7 of this TS, the specified test signals shall be applied to one receiver antenna connector, with the remaining receiver antenna connectors being terminated with 50 ohms.

5.142.2 Duplexers

Due to TDD operation, there is no need to use a duplexer in the BS.

5.142.3 Power supply options

If the BS is supplied with a number of different power supply configurations, it may not be necessary to test RF parameters for each of the power supply options, provided that it can be demonstrated that the range of conditions over which the equipment is tested is at least as great as the range of conditions due to any of the power supply configurations.

This applies particularly if a BS contains a DC rail which can be supplied either externally or from an internal mains power supply. In this case, the conditions of extreme power supply for the mains power supply options can be tested by testing only the external DC supply option. The range of DC input voltages for the test should be sufficient to verify the performance with any of the power supplies, over its range of operating conditions within the BS, including variation of mains input voltage, temperature and output current.

5.142.4 Ancillary RF amplifiers

Ancillary RF amplifier: a piece of equipment, which when connected by RF coaxial cables to the BS, has the primary function to provide amplification between the transmit and/or receive antenna connector of a BS and an antenna without requiring any control signal to fulfil its amplifying function.

The requirements of this TS shall be met with the ancillary RF amplifier fitted. At tests according to clause 6 and 7 for TX and RX respectively, the ancillary amplifier is connected to the BS by a connecting network (including any cable(s), attenuator(s), etc.) with applicable loss to make sure the appropriate operating conditions of the ancillary amplifier and the BS. The applicable connecting network loss range is declared by the manufacturer. Other characteristics and the temperature dependence of the attenuation of the connecting network are neglected. The actual attenuation value of the connecting network is chosen for each test as one of the applicable extreme values. The lowest value is used unless otherwise stated.

Sufficient tests should be repeated with the ancillary amplifier fitted and, if it is optional, without the ancillary RF amplifier to verify that the BS meets the requirements of this TS in both cases.

5.142.5 BS using antenna arrays

A BS may be configured with a multiple antenna port connection for some or all of its TRXs or with an antenna array related to one cell (not one array per TRX). This subclause applies to a BS which meets at least one of the following conditions:

- The transmitter output signals from one or more TRX appear at more than one antenna port, or
- there is more than one receiver antenna port for a TRX or per cell and an input signal is required at more than one port for the correct operation of the receiver (NOTE: diversity reception does not meet this requirement) thus the outputs from the transmitters as well as the inputs to the receivers are directly connected to several antennas (known as "aircombining"), or
- transmitters and receivers are connected via duplexers to more than one antenna

If a BS is used, in normal operation, in conjunction with an antenna system which contains filters or active elements which are necessary to meet the UTRA requirements, the tests of conformance may be performed on a system comprising the BS together with these elements, supplied separately for the purposes of testing. In this case, it must be demonstrated that the performance of the configuration under test is representative of the system in normal operation, and the conformance assessment is only applicable when the BS is used with the antenna system.

For testing of conformance of such a BS, the following procedure may be used:

Receiver tests

For each test, the test signals applied to the receiver antenna connectors shall be such that the sum of the powers of the signals applied equals the power of the test signal(s) specified in the test.

An example of a suitable test configuration is shown in figure 5.142.5.1.

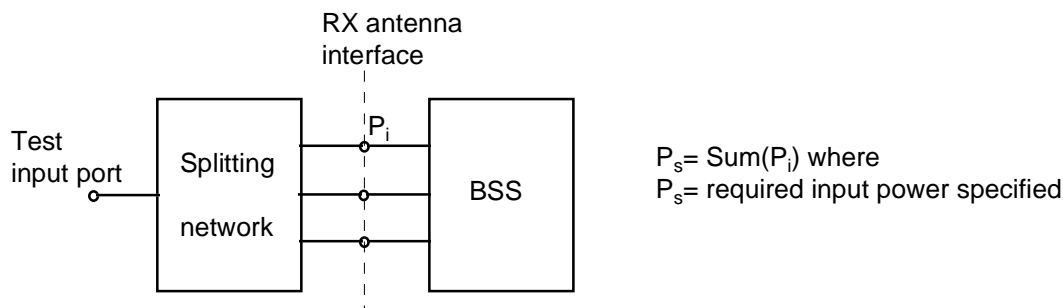

Figure 5.142.5.1: Receiver test setup

For spurious emissions from the receiver antenna connector, the test may be performed separately for each receiver antenna connector.

Transmitter tests

For each test, the conformance requirement shall be met by the sum of the signals emitted by each transmitter antenna connector. This may be assessed by separately measuring the signals emitted by each antenna connector and summing the results, or by combining the signals and performing a single measurement. The characteristics (e.g. amplitude and phase) of the combining network should be such that the power of the combined signal is maximised.

An example of a suitable test configuration is shown in figure 5.142.5.2.

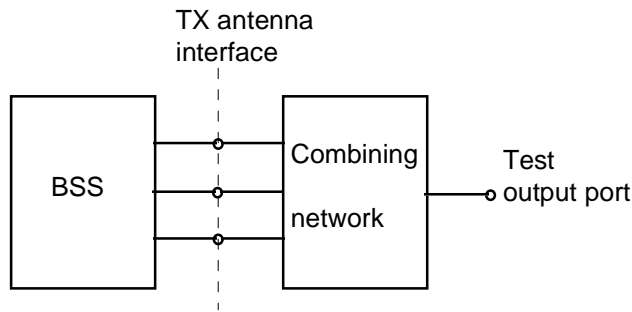

Figure 5.142.5.2: Transmitter test setup

For Intermodulation attenuation, the test may be performed separately for each transmitter antenna connector.

5.123 Overview of the conformance test requirements

Tables 5.123.1, 5.123.2 and 5.123.3 give an overview of the conformance test requirements for the transmitter, the receiver and system performance, respectively.

Table 5.123.1: Overview of the conformance tests requirements for the transmitter

Parameter	Subclause	Note
Maximum output power	6.2	manufacturer's declaration required
Frequency stability	6.3	manufacturer's declaration required
Output power dynamics	6.4	
Inner loop power control	6.4.1	
Power control steps	6.4.2	
Power control dynamic range	6.4.3	
Minimum transmit power	6.4.4	
Primary CCPCH power	6.4.5.	
Transmit OFF power	6.5	
Output RF spectrum emissions	6.6	
Occupied bandwidth	6.6.1	
Out-of-band emission	6.6.2	
Spectrum emission mask	6.6.2.1	manufacturer's declaration required
Adjacent Channel Leakage power Ratio (ACLR)	6.6.2.2	manufacturer's declaration required
Spurious emissions	6.6.3	
Mandatory requirements	6.6.3.2.1	manufacturer's declaration required
Co-existence with GSM 900	6.6.3.2.2	manufacturer's declaration required
Co-existence with DCS 1800	6.6.3.2.3	manufacturer's declaration required
Co-existence with UTRA FDD	6.6.3.2.4	manufacturer's declaration required
Transmit intermodulation	6.7	
Transmit modulation	6.8	
Modulation accuracy	6.8.1	
Peak code domain error	6.8.2	

Table 5.123.2: Overview of the conformance tests requirements for the receiver

Parameter	Subclause	Note
Reference sensitivity level	7.2	
Dynamic range	7.3	
Adjacent Channel Selectivity (ACS)	7.4	
Blocking characteristics	7.5	manufacturer's declaration required
Intermodulation characteristics	7.6	
Spurious emissions	7.7	

Table 5.123.3: Overview of the conformance test requirements for system performance

Parameter	Subclause	Note
Demodulation in static propagation conditions	8.2	
Demodulation of DCH	8.2.1	
Demodulation of DCH in multipath fading conditions	8.3	
Multipath fading Case 1	8.3.1	
Multipath fading Case 2	8.3.2	
Multipath fading Case 3	8.3.3	

5.134 Format and interpretation of tests

Each test in the following clauses has a standard format:

X Title

The title gives the name of the parameter to be tested.

X.1 Definition and applicability

This subclause gives the general definition of the parameter under consideration and specifies whether the test is applicable to all equipment or to a certain subset only.

X.2 Conformance requirements

This subclause describes the requirements the equipment under test has to fulfil to ensure compliance with the relevant specification.

In addition, this subclause contains the reference to the subclause to the 3GPP reference (or core) specification from which the conformance requirements are derived.

X.3 Test purpose

This subclause defines the purpose of the test.

X.4 Method of test

X.4.1 Initial conditions

This subclause defines the initial conditions for each test, including the basic measurement setup.

X.4.2 Procedure

This subclause describes the steps necessary to perform the test and provides further details of the test definition like point of access (e.g. antenna port), domain (e.g. frequency-span), range, weighting (e.g. bandwidth), and algorithms (e.g. averaging).

X.5 Test requirements

This subclause defines the pass/fail criteria for the equipment under test.

6.3 Frequency stability

6.3.1 Definition and applicability

Frequency stability is the ability of the BS to transmit at the assigned carrier frequency.

The requirements in this subclause shall apply to base stations intended for general-purpose applications.

6.3.2 Conformance requirements

The BS frequency stability shall be within $\pm 0,05$ ppm.

The reference for this requirement is TS 25.105 subclause 6.3.1.

TS 25.105 subclause 6.3 specifies the additional requirement that the BS shall use the same frequency source for both RF generation and the chip clock. Compliance with this requirement is demonstrated by manufacturer's declaration; see subclause 5.4; a dedicated conformance test for this requirement is not defined.

6.3.3 Test purpose

The test purpose is to verify the accuracy of the carrier frequency across the frequency range and under normal and extreme conditions.

6.3.4 Method of test

6.3.4.1 Initial conditions

- (1) The transmitter under test and all other transmitters of the base station (if any) are switched on.
- (2) The power of the transmitters not under test (if any) are controlled down.
- (3) Connect the tester to the BS antenna connector.
- (4) Set the parameters of the transmitted signal according to table 6.3.4.1.1.

Table 6.3.4.1.1: Parameters of the transmitted signal for frequency stability test

Parameter	Value/description
TDD Duty Cycle	TS i ; $i = 0, 1, 2, \dots, 14$: transmit, if i is even; receive, if i is odd.
Number of DPCH in each active TS	1
Base Station output power	maximum, according to manufacturer's declaration
Data content of DPCH	real life (sufficient irregular)

6.3.4.2 Procedure

- (1) Measure the frequency error Δf across one burst (time slot), by applying the global in-channel Tx test method described in Annex C.
- (2) Repeat step (1) for 200 bursts (time slots).
- (3) Run steps (1) and (2) for RF channels Low / Mid / High.

6.3.5 Test requirements

For all measured bursts (time slots), the frequency error, derived according to subclause 6.3.4.2, shall not exceed $0,5 \times 10E-7$.

CHANGE REQUEST

Please see embedded help file at the bottom of this page for instructions on how to fill in this form correctly.

25.142 CR 024

Current Version: **3.1.0**

GSM (AA.BB) or 3G (AA.BBB) specification number ↑

↑ CR number as allocated by MCC support team

For submission to: **RAN#8**
list expected approval meeting # here ↑

for approval
for information

strategic
non-strategic (for SMG use only)

Form: CR cover sheet, version 2 for 3GPP and SMG The latest version of this form is available from: <ftp://ftp.3gpp.org/Information/CR-Form-v2.doc>

Proposed change affects:
(at least one should be marked with an X)

(U)SIM ME UTRAN / Radio Core Network

Source: RAN WG4 **Date:** 26.05.00

Subject: Correction on Receiver tests, terminating RX port

Work item:

Category:
(only one category shall be marked with an X)

F Correction
A Corresponds to a correction in an earlier release
B Addition of feature
C Functional modification of feature
D Editorial modification

Release: Phase 2
Release 96
Release 97
Release 98
Release 99
Release 00

Reason for change: Allowing the disabling and terminating in all test cases.

Clauses affected: 7.2.4.1, 7.3.4.1, 7.4.4.1, 7.5.4.1, 7.6.4.1, 7.7.4.1

Other specs affected:

Other 3G core specifications → List of CRs:
Other GSM core specifications → List of CRs:
MS test specifications → List of CRs:
BSS test specifications → List of CRs:
O&M specifications → List of CRs:

Other comments:

7 Receiver characteristics

7.1 General

All tests unless otherwise stated in this subclause shall be conducted on Base Station Systems fitted with a full complement of Transceivers for the configuration. The manufacturer shall provide appropriate logical or physical test access to perform all tests in this subclause. Measurements shall include any RX multicoupler.

The tests in clause 7 assume that the receiver is not equipped with diversity. For receivers with diversity, the tests may be performed by applying the specified signals to one of the receiver inputs, and terminating or disabling the other(s). The tests and requirements are otherwise unchanged.

For receivers with diversity, testing of conformance shall be performed by applying the specified signals to one of the receiver inputs, and terminating or disabling the other(s).

In all the relevant subclauses in this clause all Bit Error Ratio (BER), Residual BER (RBER) and Frame Erasure Ratio (FER) measurements shall be carried out according to the general rules for statistical testing.

Unless detailed the receiver characteristic are specified at each antenna connector of the BS.

7.2 Reference sensitivity level

7.2.1 Definition and applicability

The reference sensitivity is the minimum receiver input power measured at the antenna connector at which the BER does not exceed the specific value.

The requirements in this subclause shall apply to base stations intended for general-purpose applications.

7.2.2 Conformance requirements

For the measurement channel specified in Annex A.2.1, the reference sensitivity level and performance of the BS shall be as specified in table 7.2.2.1 below.

Table 7.2.2.1: BS reference sensitivity levels

Data rate	BS reference sensitivity level (dBm)	BER
12,2 kbps	-109 dBm	BER shall not exceed 0,001

The reference for this requirement is TS 25.105 subclause 7.2.1.

7.2.3 Test purpose

The test purpose is to verify the ability of the BS to receive a prescribed single-code test signal of minimum input power under defined conditions (no interference, no multipath propagation) with a BER not exceeding a specified limit. This test is also used as a reference case for other tests to allow the assessment of degradations due to various sources of interference.

7.2.4 Method of test

7.2.4.1 Initial conditions

- (1) Connect the BS tester (UE simulator) to the antenna connector of one BS Rx port.
- (2) Terminate or disable any other BS Rx port not under test.

- (3) Set up a call between the BS tester and the BS. The characteristics of the call shall be according to the 12,2 kbit/s UL reference measurement channel specified in Annex A.2.1.
- (4) The level of BS tester output signal measured at the BS antenna connector shall be adjusted to -109 dBm.

7.2.4.2 Procedure

- (1) Measure the BER by comparing the bit sequence of the information data transmitted by the BS tester with the bit sequence obtained from the BS receiver.
- (2) Interchange the connections of the BS Rx ports and repeat the measurement according to (1).

7.2.5 Test requirements

For any BS Rx port tested, the measured BER shall not exceed 0,001.

7.3 Dynamic range

7.3.1 Definition and applicability

The receiver dynamic range is the input power range at each BS antenna connector over which the BER does not exceed a specified value.

The requirements in this subclause shall apply to base stations intended for general-purpose applications.

7.3.2 Conformance requirements

The static BER reference performance as specified in subclause 7.2 shall be met over a receiver input range of 30 dB above the specified reference sensitivity level for the 12,2 kbit/s channel.

The reference for this requirement is TS 25.105 subclause 7.3.

7.3.3 Test purpose

The test purpose is to verify the ability of the BS to receive a prescribed single-code test signal of maximum input power under defined conditions (no interference, no multipath) with a BER not exceeding a specified limit.

7.3.4 Method of test

7.3.4.1 Initial conditions

- (1) Connect the BS tester (UE simulator) to the antenna connector of one BS Rx port.
- (2) Terminate or disable any other BS Rx port not under test.
- (3) Set up a call between the BS tester and the BS. The characteristics of the call shall be according to the 12,2 kbit/s UL reference measurement channel specified in Annex A.2.1.
- (4) The level of the BS tester output signal measured at the BS antenna connector shall be adjusted to $(-110 + 30)$ dBm.

7.3.4.2 Procedure

- (1) Measure the BER by comparing the bit sequence of the information data transmitted by the BS tester with the bit sequence obtained from the BS receiver.
- (2) Interchange the connections of the BS Rx ports and repeat the measurement according to (1)

7.3.5 Test requirements

For any BS Rx port tested, the measured BER shall not exceed 0,001.

7.4 Adjacent Channel Selectivity (ACS)

7.4.1 Definition and applicability

Adjacent channel selectivity (ACS) is a measure of the receiver ability to receive a wanted signal at its assigned channel frequency in the presence of an adjacent channel signal at a given frequency offset from the center frequency of the assigned channel.

The requirements in this subclause shall apply to base stations intended for general-purpose applications.

7.4.2 Conformance requirements

The BER, measured on the wanted signal in the presence of an interfering signal, shall not exceed 0,001 for the parameters specified in table 7.4.2.2.1.

Table 7.4.2.2.1: Parameters of the wanted signal and the interfering signal for ACS testing

Parameter	Level	Unit
Data rate	12,2	kbit/s
Wanted signal	Reference sensitivity level + 6 dB	dBm
Interfering signal	-52	dBm
Fuw (modulated)	5	MHz
NOTE: Fuw is the frequency offset of the unwanted interfering signal from the assigned channel frequency of the wanted signal.		

The reference for this requirement is TS 25.105 subclause 7.4.1.

7.4.3 Test purpose

The test purpose is to verify the ability of the BS receiver filter to sufficiently suppress interfering signals in the channels adjacent to the wanted channel.

7.4.4 Method of test

7.4.4.1 Initial conditions

- (1) Connect an UE simulator operating at the assigned channel frequency of the wanted signal and a signal generator used to produce the interfering signal in the adjacent channel to the antenna connector of one Rx port.
- (2) Terminate or disable any other Rx port not under test.
- (3) Set up a call between the UE simulator and the BS tester. The characteristics of the call shall be set according to the UL reference measurement channel (12,2 kbit/s) specified in Annex A.2.1. The level of the UE simulator signal measured at the BS antenna connector shall be adjusted to the value specified in table 7.4.2.2.1.
- (4) Set the signal generator to produce an interfering signal that is equivalent to a continuous wideband CDMA signal with one code of chip frequency 3,84 Mchip/s, filtered by an RRC transmit pulse-shaping filter with roll-off $\alpha = 0,22$. The level of the interfering signal measured at the BS antenna connector shall be adjusted to the value specified in table 7.4.2.2.1.

7.4.4.2 Procedure

- (1) Set the center frequency of the interfering signal to 5 MHz above the assigned channel frequency of the wanted signal.
- (2) Measure the BER of the wanted signal at the BS receiver.
- (3) Set the center frequency of the interfering signal to 5 MHz below the assigned channel frequency of the wanted signal.
- (4) Measure the BER of the wanted signal at the BS receiver.
- (5) Interchange the connections of the BS Rx ports and repeat the measurements according to steps (1) to (4).

7.4.5 Test requirements

The BER measured according subclause 7.4.4.2 to shall not exceed 0,001.

7.5 Blocking characteristics

7.5.1 Definition and applicability

The blocking characteristics is a measure of the receiver ability to receive a wanted signal at its assigned channel frequency in the presence of an unwanted interferer on frequencies other than those of the adjacent channels. The blocking performance shall apply at all frequencies as specified in tables 7.5.2.1 or 7.5.2.2, respectively, using a 1 MHz step size.

The requirements in this subclause shall apply to base stations intended for general-purpose applications.

7.5.2 Conformance requirements

The static reference performance as specified in clause 7.2 should be met with a wanted and an interfering signal coupled to the BS antenna input using the parameters specified in tables 7.5.2.1 or 7.5.2.2, respectively.

Table 7.5.2.1: Blocking requirements for operating bands defined in subclause 4.2 a)

Center frequency of interfering signal	Interfering signal level	Wanted signal level	Minimum offset of interfering signal	Type of interfering signal
1900 – 1920 MHz, 2010 – 2025 MHz	-40 dBm	<REFSENS> + 6 dB	10 MHz	WCDMA signal with one code
1880 – 1900 MHz, 1990 – 2010 MHz, 2025 – 2045 MHz	-40 dBm	<REFSENS> + 6 dB	10 MHz	WCDMA signal with one code
1920 – 1980 MHz	-40 dBm	<REFSENS> + 6 dB	10 MHz	WCDMA signal with one code
1 - 1880 MHz, 1980 – 1990 MHz, 2045 – 12750 MHz	-15 dBm	<REFSENS> + 6 dB	—	CW carrier

Table 7.5.2.2: Blocking requirements for operating bands defined in subclause 4.2 b), c)

Center frequency of interfering signal	Interfering signal level	Wanted signal level	Minimum offset of interfering signal	Type of interfering signal
1850 – 1990 MHz	-40 dBm	<REFSENS> + 6 dB	10 MHz	WCDMA signal with one code
1830 – 1850 MHz, 1990 – 2010 MHz	-40 dBm	<REFSENS> + 6 dB	10 MHz	WCDMA signal with one code
1 – 1830 MHz, 2045 – 12750 MHz	-15 dBm	<REFSENS> + 6 dB	—	CW carrier

The reference for this requirement is TS 25.105 subclause 7.5.

7.5.3 Test purpose

The test stresses the ability of the BS receiver to withstand high-level interference from unwanted signals at frequency offsets of 10 MHz or more, without undue degradation of its sensitivity.

7.5.4 Method of test

7.5.4.1 Initial conditions

- (1) Connect an UE simulator operating at the assigned channel frequency of the wanted signal and a signal generator to the antenna connector of one Rx port.
- (2) Terminate or disable any other Rx port not under test.
- (3) Set up a call between the UE simulator and the BS tester. The characteristics of the call shall be set according to the UL reference measurement channel (12,2 kbit/s) specified in Annex A.2.1. The level of the UE simulator signal measured at the BS antenna connector shall be set to 6 dB above the reference sensitivity level specified in subclause 7.2.2.

7.5.4.2 Procedure

- (1) Set the signal generator to produce an interfering signal at a frequency offset F_{uw} from the assigned channel frequency of the wanted signal which is given by

$$F_{uw} = \pm (n \times 1 \text{ MHz}),$$

where n shall be increased in integer steps from $n = 10$ up to such a value that the center frequency of the interfering signal covers the range from 1 MHz to 12,75 GHz. The interfering signal level measured at the antenna connector shall be set in dependency of its center frequency, as specified in tables 7.5.2.1 or 7.5.2.2, respectively. The type of the interfering signal is either equivalent to a continuous wideband CDMA signal with one code of chip frequency 3,84 Mchip/s, filtered by an RRC transmit pulse-shaping filter with roll-off $\alpha = 0,22$, or a CW signal; see tables 7.5.2.1 or 7.5.2.2, respectively.

- (2) Measure the BER of the wanted signal at the BS receiver.
- (3) Interchange the connections of the BS Rx ports and repeat the measurements according to steps (1) and (2).

NOTE: The test procedure as defined in steps (1) and (2) requests to carry out more than 10000 BER measurements. To reduce the time needed for these measurements, it may be appropriate to conduct the test in two phases: During phase 1, BER measurements are made on all center frequencies of the interfering signal as requested but with a reduced confidence level, with the aim to identify those frequencies which require more detailed investigation. In phase 2, detailed measurements are made only at those critical frequencies identified before, applying the required confidence level.

7.5.5 Test requirements

In all measurements made according to subclause 7.5.4.2, the BER shall not exceed 0,001.

7.6 Intermodulation characteristics

7.6.1 Definition and applicability

Third and higher order mixing of two interfering RF signals can produce an interfering signal in the band of the desired channel. Intermodulation response rejection is a measure of the capability of the receiver to receive a wanted signal on its assigned channel frequency in the presence of two or more interfering signals which have a specific frequency relationship to the wanted signal.

The requirements in this subclause shall apply to base stations intended for general-purpose applications.

7.6.2 Conformance requirements

The static reference performance as specified in clause 7.2 should be met when the following signals are coupled to the BS antenna input.

- A wanted signal at the assigned channel frequency, 6 dB above the static reference level.
- Two interfering signals with the parameters specified in table 7.6.2.1.

Table 7.6.2.1: Parameters of the interfering signals for intermodulation characteristics testing

Interfering Signal Level	Offset	Type of Interfering Signal
- 48 dBm	10 MHz	CW signal
- 48 dBm	20 MHz	WCDMA signal with one code

The reference for this requirement is TS 25.105 subclause 7.6.

7.6.3 Test purpose

The test purpose is to verify the ability of the BS receiver to inhibit the generation of intermodulation products in its non-linear elements caused by the presence of two high-level interfering signals at frequencies with a specific relationship to the frequency of the wanted signal.

7.6.4 Method of test

7.6.4.1 Initial conditions

- (1) Connect an UE simulator operating at the assigned channel frequency of the wanted signal and two signal generators to the antenna connector of one Rx port.
- (2) Terminate or disable any other Rx port not under test.
- (3) Set up a call between the UE simulator and the BS tester. The characteristics of the call shall be set according to the UL reference measurement channel (12,2 kbit/s) specified in Annex A.2.1. The level of the UE simulator signal measured at the BS antenna connector shall be set to 6 dB above the reference sensitivity level specified in subclause 7.2.2.
- (4) Set the first signal generator to produce a CW signal with a level measured at the BS antenna connector of - 48 dBm.
- (5) Set the second signal generator to produce an interfering signal equivalent to a wideband CDMA signal with one code of chip frequency 3,84 Mchip/s, filtered by an RRC transmit pulse-shaping filter with roll-off $\alpha = 0,22$. The level of the signal measured at the BS antenna connector shall be set to - 48 dBm.

7.6.4.2 Procedure

- (1) The frequency of the first and the second signal generator shall be set to 10 MHz and 20 MHz, respectively, above the assigned channel frequency of the wanted signal.
- (2) Measure the BER of the wanted signal at the BS receiver.
- (3) The frequency of the first and the second signal generator shall be set to 10 MHz and 20 MHz, respectively, below the assigned channel frequency of the wanted signal.
- (4) Measure the BER of the wanted signal at the BS receiver.
- (5) Interchange the connections of the BS Rx ports and repeat the measurements according to steps (1) to (4).

7.6.5 Test requirements

The BER measured according subclause 7.6.4.2 to shall not exceed 0,001.

7.7 Spurious emissions

7.7.1 Definition and applicability

The spurious emissions power is the power of emissions generated or amplified in a receiver that appear at the BS antenna connector. The requirements apply to all BS with separate Rx and Tx antenna connectors. For BS equipped with only a single antenna connector for both transmitter and receiver, the requirements of subclause 6.6.3 shall apply to this port, and this test need not be performed.

The requirements in this subclause shall apply to base stations intended for general-purpose applications.

7.7.2 Conformance requirements

The power of any spurious emission shall not exceed the values given in table 7.7.2.1.

Table 7.7.2.1: Receiver spurious emission requirements

Band	Maximum level	Measurement Bandwidth	Note
9 kHz – 1 GHz	-57 dBm	100 kHz	
1 GHz – 1,9 GHz	-47 dBm	1 MHz	With the exception of frequencies between 12,5 MHz below the first carrier frequency and 12,5 MHz above the last carrier frequency used by the BS
1,900 – 1,980 GHz	-78 dBm	3,84 MHz	With the exception of frequencies between 12,5 MHz below the first carrier frequency and 12,5 MHz above the last carrier frequency used by the BS
1,980 – 2,010 GHz	-47 dBm	1 MHz	With the exception of frequencies between 12,5 MHz below the first carrier frequency and 12,5 MHz above the last carrier frequency used by the BS
2,010 – 2,025 GHz	-78 dBm	3,84 MHz	With the exception of frequencies between 12,5 MHz below the first carrier frequency and 12,5 MHz above the last carrier frequency used by the BS
2,025 GHz – 12,75 GHz	-47 dBm	1 MHz	With the exception of frequencies between 12,5 MHz below the first carrier frequency and 12,5 MHz above the last carrier frequency used by the BS

The reference for this requirement is TS 25.105 subclause 7.7.1.

7.7.3 Test purpose

The test purpose is to verify the ability of the BS to limit the interference caused by receiver spurious emissions to other systems.

7.7.4 Method of test

7.7.4.1 Initial conditions

(1) Connect the measuring equipment to the antenna connector of one BS Rx port.

Terminate or disable any other BS Rx port not under test.

(2) Set the BS receiver to operational mode.

Set the BS to transmit a signal with parameters according to table 7.7.4.1.1.

CHANGE REQUEST

Please see embedded help file at the bottom of this page for instructions on how to fill in this form correctly.

25.142 CR 025

Current Version: **3.1.0**

GSM (AA.BB) or 3G (AA.BBB) specification number ↑

↑ CR number as allocated by MCC support team

For submission to: **RAN #8**
list expected approval meeting # here ↑

for approval
for information

strategic
non-strategic (for SMG use only)

Form: CR cover sheet, version 2 for 3GPP and SMG The latest version of this form is available from: <ftp://ftp.3gpp.org/Information/CR-Form-v2.doc>

Proposed change affects:
(at least one should be marked with an X)

(U)SIM ME UTRAN / Radio Core Network

Source:

RAN WG4

Date:

22.5.2000

Subject:

Revision of Annex C: Global in-channel Tx test

Work item:

TS 25.142

Category:

F Correction
A Corresponds to a correction in an earlier release
B Addition of feature
C Functional modification of feature
D Editorial modification

(only one category shall be marked with an X)

Release:

Phase 2
Release 96
Release 97
Release 98
Release 99
Release 00

Reason for change:

Correction of errors and editorial improvements

Clauses affected:

Annex C

Other specs affected:

Other 3G core specifications → List of CRs:
Other GSM core specifications → List of CRs:
MS test specifications → List of CRs:
BSS test specifications → List of CRs:
O&M specifications → List of CRs:

Other comments:

~~Annex C (normative): Global in-channel Tx test~~

~~C.1 — General~~

The global in-channel Tx test enables the measurement of all relevant parameters that describe the in-channel quality of the output signal of the Tx under test in a single measurement process.

~~C.2 — Definition of the process~~

~~C.2.1 — Basic principle~~

The process is based on the comparison of the actual ~~output signal of the Tx under test~~, received by an ideal receiver, with a ~~reference signal~~, that is generated by the measuring equipment and represents an ideal error free received signal. All signals are represented as equivalent (generally complex) baseband signals.

~~C.2.2 — Output signal of the Tx under test~~

The output signal of the Tx under test is recorded through a matched filter (RRC 0.22, correct in shape and in position on the frequency axis) at one sample per chip.

Depending on the parameter to be evaluated, it is appropriate to represent the recorded signal in one of the following two different forms:

Form 1 (representing the physical signal in the entire measurement interval):

one vector \mathbf{Z} , containing $N = n \times m$ complex samples;

with

n : number of symbols in the measurement interval;

m : number of chips per symbol.

Form 2 (derived from form 1 by separating the samples into symbol intervals):

n time sequential vectors \mathbf{z} with m complex samples, where each vector comprises a symbol interval.

~~C.2.3 — Reference signal~~

The reference signal is constructed by the measuring equipment according to the relevant Tx specifications, filtered by a matched filter and sampled at the Inter-Symbol Interference free instants.

Depending of the parameter to be evaluated, it is appropriate to represent the reference set of samples in one of the following three different forms:

Form 1 (representing the physical signal in the entire measurement interval):

one vector \mathbf{R} , containing $N = n \times m$ complex samples;

with

n : number of symbols in the measurement interval;

~~m: number of chips per symbol.~~

~~Form 2 (derived from form 1 by separating the samples into symbol intervals):~~

~~n time sequential vectors \mathbf{r} with m complex samples, where each vector comprises a symbol interval.~~

~~(Note: Clarification is needed in case of a multi code with multi rate signal)~~

~~Form 3 (derived from form 2 by separating the samples into code signals):~~

~~n sequential expressions $\sum_{i=1}^k \mathbf{r} \mathbf{c}_i$,~~

~~with~~

~~k: number of codes;~~

~~a single summand $\mathbf{r} \mathbf{c}_i$ representing the vector of one code i, containing m complex samples of the symbol interval~~

~~C.2.4 Provisions in case of multi code signals~~

~~In case of multi code signals, the code multiplex shall contain only orthogonal codes. (Otherwise non orthogonal codes must be eliminated (e.g. by time windowing the measurement interval or switch off).~~

~~C.2.5 Classification of measurement results~~

~~The measurement results achieved by the global in channel Tx test can be classified into two types:~~

~~Results of type 1, where the error free parameter has a non zero magnitude. These parameters are:~~

~~RF Frequency~~

~~(Chip Frequency)~~

~~Power~~

~~Code Domain Power (in case of multi code)~~

~~Timing (only for MS)~~

~~Results of type 2, where the error free parameter has value zero. These parameters are:~~

~~Error Vector Magnitude~~

~~Peak Code Domain Power Error~~

~~C.2.6 Process definition to achieve results of type 1~~

~~The reference signal is varied with respect to the parameters mentioned in subclause C.2.5 under "results of type 1" in order to achieve best fit with the recorded signal under test (output signal of the Tx under test, filtered and sampled according to subclause C.2.2). Best fit is achieved when the RMS difference value between the signal under test and the varied reference signal is an absolute minimum. The varied reference signal in this best fit case will be called \mathbf{R}' .~~

The varied parameters leading to \mathbf{R}' represent directly the wanted results of type 1. These measurement parameters are expressed as deviation from the reference value with dimensions same as the reference value.

In case of multi code, the type 1 parameters (frequency, (chip frequency) and timing) are varied commonly for all codes such that the process returns one frequency error, (one chip frequency error), one timing error.

(These parameters are not varied on the individual codes signals such that the process returns k frequency errors.... (k: number of codes)).

Only the type 1 parameters (code powers) are varied individually such that the process returns k code powers (k: number of codes).

~~C.2.7 Process definition to achieve results of type 2~~

The difference between the signal under test (\mathbf{Z} ; see subclause C.2.2) and the reference signal after the minimum process (\mathbf{R}' ; see subclause C.2.6) is the error vector \mathbf{E} versus time:

$$\mathbf{E} = \mathbf{Z} - \mathbf{R}'$$

Depending on the parameter to be evaluated, it is appropriate to represent \mathbf{E} in one of the following two different forms:

Form 1 (representing the physical error signal in the entire measurement interval):

One vector \mathbf{E} , containing $N = n \times m$ complex samples;

with

n : number of symbols in the measurement interval

m : number of chips per symbol

Form 2 (derived from form 1 by separating the samples into symbol intervals):

n time sequential vectors \mathbf{e} with m complex samples comprising one symbol interval

\mathbf{E} gives results of type 2 applying the two algorithms defined in subclauses C.2.7.1 and C.2.7.2.

~~C.2.7.1 Error Vector Magnitude~~

The Error Vector Magnitude EVM is calculated according to the following steps:

(1) Take the error vector \mathbf{E} defined in subclause C.2.7 (form 1) and calculate the RMS value of \mathbf{E} chip wise over the entire measurement interval; the result will be called $\text{RMS}(\mathbf{E})$.

(2) Take the reference vector \mathbf{R} defined in subclause C.2.3 (form 1) and calculate the RMS value of \mathbf{R} chip wise over the entire measurement interval; the result will be called $\text{RMS}(\mathbf{R})$

(3) Calculate EVM according to

$$\text{EVM} = \frac{\text{RMS}(\mathbf{E})}{\text{RMS}(\mathbf{R})} \times 100\%$$

— (here, EVM is relative and expressed in %)

C.2.7.2 Peak Code Domain Power Error

The Peak Code Domain Power Error is calculated according to the following steps:

(1) Take the error vectors \mathbf{e} defined in subclause C.2.7 (form 2) and the reference vectors \mathbf{r}_i defined in subclause C.2.3 (form 3) and calculate the inner product of \mathbf{e} and \mathbf{r}_i chip wise over the symbol duration for all symbols of the measurement interval and for all permitted codes of the code space.

— This gives a matrix of format $k \times n$, each value representing an error voltage connected with a specific symbol and a specific code, which can be exploited in a large variety.

— k : number of codes

— n : number of symbols in the measurement interval

(2) Calculate k RMS values, each RMS value unifying n symbols within one code.

— (This values can be called "absolute Code EVMs" [Volt].)

(3) Find the peak value among the k "absolute Code EVMs".

— (This value can be called "absolute Peak Code EVM" [Volt].)

(4) Calculate the following term:

$$10 \lg \frac{(\text{absolute Peak - Code - EVM})^2}{(\text{RMS}(\mathbf{R}))^2} \text{ dB.}$$

— This term is called Peak Code Domain Power Error (a relative value in dB).

(5) If the values $\text{RMS}(\mathbf{r})$ are not constant during the measurement interval, Peak Code Domain Power Error should be expressed absolutely instead by the term:

$$\frac{(\text{absolute Peak - Code - EVM})^2}{50 \text{ Ohm}}$$

This term is called Absolute Peak Code Domain Power Error [Watt or dBm]

C.3 Applications

This process is applicable to the following paragraphs:

6.3—Frequency Stability

6.4—Output Power Dynamics

6.5—Transmit OFF Power

6.8—Transmit Modulation

— [Chip Frequency]

Annex C (normative): Global in-channel Tx test

C.1 General

The global in-channel Tx test enables the measurement of all relevant parameters that describe the in-channel quality of the output signal of the Tx under test in a single measurement process.

The objective of this Annex is to list the results that shall be available from the global in-Channel TX-Test. To aid understanding, an example algorithmic description of the measurement process is provided. It is not intended that this particular method is required. It is however required that any algorithm that is used for in-channel Tx tests should deliver the required results with the required accuracy.

All notes referred to in the various subclauses of C.2 are put together in clause C.4

C.2 Definition of the process

C.2.1 Basic principle

The process is based on the comparison of the actual **output signal of the Tx under test**, received by an ideal receiver, with a **reference signal**, that is generated by the measuring equipment and represents an ideal error free received signal. All signals are represented as equivalent (generally complex) baseband signals.

C.2.2 Output signal of the Tx under test

The output signal of the Tx under test is acquired by the measuring equipment, filtered by a matched filter (RRC characteristic with roll-off $\alpha = 0,22$, correct in shape and in position on the frequency axis) and stored at one sample per chip at the intersymbol interference free instants.

The following form represents the physical signal in the entire measurement interval:

one vector **Z**, containing $N = ns \times sf + ma$ complex samples;

with

ns: number of symbols in the measurement interval;

sf: number of chips per symbol. (sf: spreading factor) (see Note: Symbol length)

ma: number of midamble chips (TDD only)

C.2.3 Reference signal

The reference signal is constructed by the measuring equipment according to the relevant Tx specifications.

It is filtered by the same matched filter, mentioned in C.2.2, and stored at the intersymbol interference free instants. The following form represents the reference signal in the entire measurement interval:

one vector **R**, containing $N = ns \times sf + ma$ complex samples;

where ns, sf and ma have the same meaning as defined above in C.2.2.

C.2.4 Classification of measurement results

The measurement results achieved by the global in-channel Tx test can be classified into two types:

- **Results of type “deviation”**, where the error-free parameter has a non-zero magnitude. (These are the parameters that represent the signal). These parameters are:

RF Frequency

Power _____ (in case of single code)

Code Domain Power _____ (in case of multi-code)

Timing _____ (only for UE)

(Additional parameters: see Note: Deviation)

- **Results of type “residual”**, where the error-free parameter has value zero. (These are the parameters that represent the error values of the measured signal; ideally, their magnitude is zero). These parameters are:

Error Vector Magnitude (EVM)

Peak Code Domain Error (PCDE)

(Additional parameters: see Note: Residual)

C.2.5 Process definition to achieve results of type “deviation”

The reference signal (**R**; see subclause C.2.3) is varied with respect to the parameters mentioned in subclause C.2.4 under "results of type deviation" in order to achieve best fit with the recorded signal under test (**Z**; see subclause C.2.2). Best fit is achieved when the RMS difference value between the signal under test and the varied reference signal is an absolute minimum. The varied reference signal, after the best-fit process, will be called **R'**.

Those parameter values, which - after the best-fit process – are leading to **R'**, represent directly the wanted results of type “deviation”. These parameter values are expressed as deviations from the reference value, using the same units as the corresponding reference value.

In case of multi-code transmission, the best-fit process of the type “deviation” parameters frequency, timing (and any additional parameter as e.g. RF phase) is not done with respect to the individual codes, but commonly for the complete code set used; therefore, the process returns one measurement value only for each parameter.

The only exception is the type “deviation” parameter Code Domain Power: The Code Domain Power is varied individually for each used code; therefore, the process returns k individual code power deviations (k: number of codes).

C.2.6 Process definition to achieve results of type “residual”

The difference between the varied reference signal (**R'**; see subclause C.2.5.) and the Tx signal under test (**Z**; see subclause C.2.2) is the error vector **E** versus time:

$$\underline{\underline{E = Z - R'}}$$

Depending on the parameter to be evaluated, it is appropriate to represent **E** in one of the following two different forms:

- **Form EVM** (representing the physical error signal in the entire measurement interval)

One vector \mathbf{E} , containing $N = n_s \times s_f + m_a$ complex samples;

where n_s , s_f and m_a have the same meaning as defined above in C.2.2.

- **Form PCDE** (derived from Form EVM by separating the samples into symbol intervals)

n_s time-sequential vectors \mathbf{e} with s_f complex samples comprising one symbol interval.

\mathbf{E} gives results of type "residual" applying the two algorithms defined in subclauses C.2.6.1 and C.2.6.2.

C.2.6.1 Error Vector Magnitude (EVM)

The Error Vector Magnitude EVM is calculated according to the following steps:

- (1) Take the error vector \mathbf{E} defined in subclause C.2.6 (Form EVM) and calculate the RMS value of \mathbf{E} ; the result will be called $\text{RMS}(\mathbf{E})$.
- (2) Take the reference vector \mathbf{R} defined in subclause C.2.3 and calculate the RMS value of \mathbf{R} ; the result will be called $\text{RMS}(\mathbf{R})$.
- (3) Calculate EVM according to:

$$\text{EVM} = \frac{\text{RMS}(\mathbf{E})}{\text{RMS}(\mathbf{R})} \times 100\% \quad \text{(here, EVM is relative and expressed in \%)}$$

(see Note: TDD)

C.2.6.2 Peak Code Domain Error (PCDE)

The Peak Code Domain Error is calculated according to the following steps:

- (1) Take the error vectors \mathbf{e} defined in subclause C.2.6 (Form PCDE)
- (2) Take the orthogonal vectors of the spreading code set \mathbf{C} (all codes belonging to one spreading factor) as defined in TS 25.213 and TS 25.223 (range +1, -1). (see Note: Symbol length)
- (3) To achieve meaningful results, it is necessary to descramble \mathbf{e} , leading to \mathbf{e}' (see Note: Scrambling code)
- (4) Calculate the inner product of \mathbf{e}' with \mathbf{C} . Do this for all symbols of the measurement interval and for all codes in the code space.
This gives an array of format $k \times n_s$, each value representing an error-vector representing a specific symbol and a specific code, which can be exploited in a variety of ways.

k : number of codes

n_s : number of symbols in the measurement interval

- (5) Calculate k RMS values, each RMS value unifying n symbols within one code. (These values can be called "Absolute CodeEVMs" [Volt].)
- (6) Find the peak value among the k "absolute Code-EVMs". (This value can be called "Absolute PeakCodeEVM" [Volt].)
- (7) Calculate PCDE according to:

$$\text{PCDE} = 10 \lg \frac{(\text{absolute PeakCodeEVM})^2}{(\text{RMS}(\mathbf{R}))^2} \text{ dB} \quad \text{(a relative value in dB).}$$

see Note: TDD

see Note: Synch channel

C.3 Applications

This process may be applied in the measurements defined in the following subclauses:

6.3 Frequency Stability

6.4 Output Power Dynamics

6.4.2 Power control steps

6.4.3 Power control dynamic range

6.4.4 Minimum transmit power

6.4.5 Primary CCPCH power

6.6.2.2 Adjacent Channel Leakage power Ratio (ACLR)

6.8 Transmit Modulation

6.8.1 Modulation accuracy

6.8.2 Peak Code Domain Error

C.4 Notes

NOTE: Symbol length

A general code-multiplexed signal is multi-code and multi-rate. In order to avoid unnecessary complexity, the measurement applications use a unique symbol-length, corresponding to a specific spreading factor, regardless of the really intended spreading factor. Nevertheless, the complexity with a multi-code / multi-rate signal can be mastered by introducing appropriate definitions.

NOTE: Deviation

It is conceivable to regard more parameters as type „deviation“, e.g. chip clock and RF phase. However, because chip clock and RF frequency are linked together by a statement in the core specifications [1], it is sufficient to process RF frequency only. The parameter RF phase must be varied within the best-fit process (C.2.5). Although necessary, this parameter-variation does not describe any error, as the modulation schemes used in the system do not depend on an absolute RF-phase.

NOTE: Residual

It is conceivable to regard more parameters as type „residual“, e.g. IQ origin offset. As it is not the intention of the test to separate for different error sources, but to quantify the quality of the signal, all such parameters are not extracted by the best-fit process, instead remain part of EVM and PCDE.

NOTE: Scrambling code

To interpret the measurement results in practice, it should be kept in mind that erroneous code power on unused codes is generally de-scrambled differently under test conditions and under real life conditions, whereas erroneous code power on used codes is generally de-scrambled equally under test conditions and under real life conditions. It might be indicated if a used or unused code hits PCDE.

NOTE: TDD

EVM covers the midamble part as well as the data part; however PCDE disregards the midamble part.

NOTE: Synch channel

A BS signal contains a physical synch channel, which is non-orthogonal, related to the other DPCHs. In this context note: The code channel bearing the result of PCDE is exactly one of the DPCHs (never the synch channel). The origin of PCDE (erroneous code power) can be any DPCH and/or the synch channel.

CHANGE REQUEST

Please see embedded help file at the bottom of this page for instructions on how to fill in this form correctly.

25.142 CR 026

Current Version: **3.1.0**

GSM (AA.BB) or 3G (AA.BBB) specification number ↑

↑ CR number as allocated by MCC support team

For submission to: **RAN #8**
list expected approval meeting # here ↑

for approval
for information

strategic (for SMG use only)
non-strategic

Form: CR cover sheet, version 2 for 3GPP and SMG The latest version of this form is available from: <ftp://ftp.3gpp.org/Information/CR-Form-v2.doc>

Proposed change affects:
(at least one should be marked with an X)

(U)SIM ME UTRAN / Radio Core Network

Source:

RAN WG4

Date:

22.5.2000

Subject:

Conformance test description for spectrum emission mask

Work item:

TS 25.142

Category:

F Correction
A Corresponds to a correction in an earlier release
B Addition of feature
C Functional modification of feature
D Editorial modification

(only one category shall be marked with an X)

Release:

Phase 2
Release 96
Release 97
Release 98
Release 99
Release 00

Reason for change:

Alignment of the conformance test description for spectrum emission mask with recent amendments incorporated into the core specification TS 25.105 via CR 030. The first columns in tables 6.6.2.1.2.1 - 4 are removed, as these are no longer relevant to conformance testing. The diagram is removed since it relates to the first column; however, it may be considered useful to add a new diagram to provide clarification.

Clauses affected:

6.6.2., 6.6.2.1.2, 6.6.2.1.4.2

Other specs affected:

Other 3G core specifications → List of CRs:
Other GSM core specifications → List of CRs:
MS test specifications → List of CRs:
BSS test specifications → List of CRs:
O&M specifications → List of CRs:

Other comments:

6.6.2 Out of band emission

Out of band emissions are unwanted emissions immediately outside the {channel} bandwidth resulting from the modulation process and non-linearity in the transmitter but excluding spurious emissions. This out of band emission limit requirement can be specified both in terms of a spectrum emission mask and adjacent channel power ratio for the transmitter.

6.6.2.1 Spectrum emission mask

6.6.2.1.1 Definition and applicability

The spectrum emission mask specifies the limit of the transmitter out of band emissions at frequency offsets from the assigned channel frequency of the wanted signal between 2,5 MHz and 12,5 MHz.

The mask defined in subclause 6.6.2.1.2 below may be mandatory in certain regions. In other regions this mask may not be applied.

6.6.2.1.2 Conformance requirements

For regions where this subclause applies, the BS spectrum emissions shall be within the mask defined in tables 6.6.2.1.2.1 to 6.6.2.1.2.4. A graphical representation of these tables is given in figure 6.6.2.1.2.1. This mask requirement shall be met by a base station transmitting on a single RF carrier configured in accordance with the manufacturer's specification. Emissions shall not exceed the maximum level specified by the mask in tables 6.6.2.1.2.1 to 6.6.2.1.2.4 in the frequency range with of f_{offset} Δf from 2,5 MHz to $\Delta f_{offset_{max}}$ from the carrier frequency, where:

- f_{offset} is the separation between the carrier frequency and the centre of the measurement filter
- $f_{offset_{max}}$ is either 12,5 MHz or the offset to the UMTS Tx band edge as defined in subclause 4.2, whichever is the greater. The maximum offset Δf_{max} is 12,5 MHz.

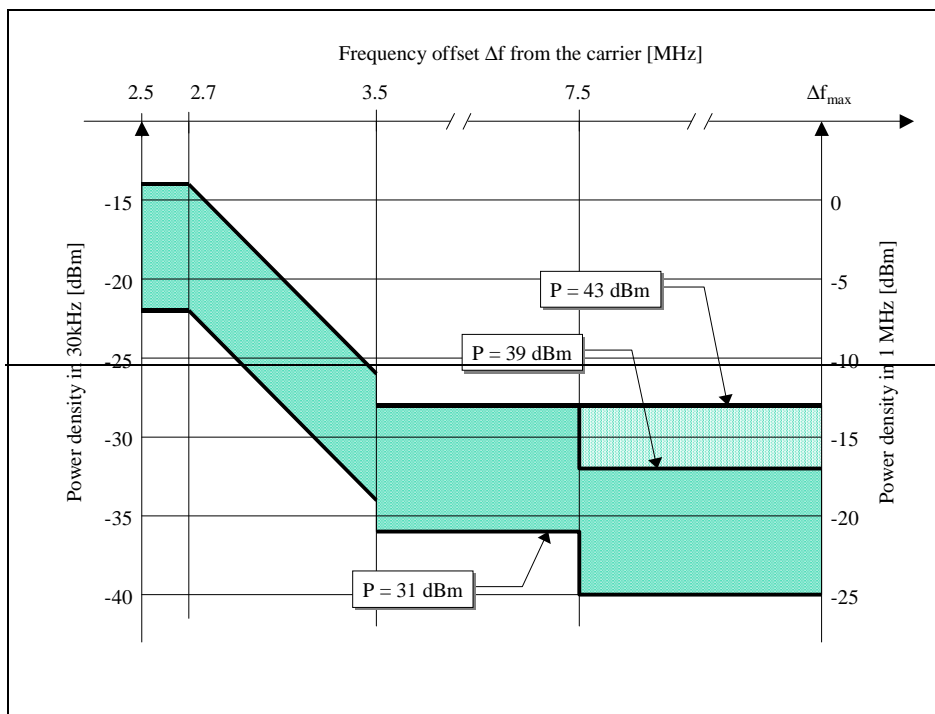

Figure 6.6.2.1.2.1: Spectrum emission mask

Table 6.6.2.1.2.1: Spectrum emission mask values, BS maximum rated output power $PRAT \geq 43$ dBm

Frequency offset Δf	Frequency offset of measurement filter centre frequency, f_{offset}	Maximum level	Measurement bandwidth
$2,5 \leq \Delta f < 2,7$ MHz	$2,515 \text{ MHz} \leq f_{\text{offset}} < 2,715 \text{ MHz}$	-14 dBm	30 kHz [†]
$2,7 \leq \Delta f < 3,5$ MHz	$2,715 \text{ MHz} \leq f_{\text{offset}} < 3,515 \text{ MHz}$	$-14 - 15 \cdot (f_{\text{offset}} - 2,715)$ dBm	30 kHz [†]
	$3,515 \text{ MHz} \leq f_{\text{offset}} < 4,0 \text{ MHz}$	-26 dBm	30 kHz
	$4,0 \text{ MHz} \leq f_{\text{offset}} < 8,0 \text{ MHz}$	-13 dBm	1 MHz
$3,5 \leq \Delta f \leq \Delta f_{\text{max}}$ MHz	$4,0 \text{ MHz} \leq f_{\text{offset}} < f_{\text{offset}_{\text{max}}}$	-13 dBm	1 MHz [‡]

Table 6.6.2.1.2.2: Spectrum emission mask values, BS maximum rated output power $39 \leq PRAT < 43$ dBm

Frequency offset Δf	Frequency offset of measurement filter centre frequency, f_{offset}	Maximum level	Measurement bandwidth
$2,5 \leq \Delta f < 2,7$ MHz	$2,515 \text{ MHz} \leq f_{\text{offset}} < 2,715 \text{ MHz}$	-14 dBm	30 kHz [†]
$2,7 \leq \Delta f < 3,5$ MHz	$2,715 \text{ MHz} \leq f_{\text{offset}} < 3,515 \text{ MHz}$	$-14 - 15 \cdot (f_{\text{offset}} - 2,715)$ dBm	30 kHz [†]
	$3,515 \text{ MHz} \leq f_{\text{offset}} < 4,0 \text{ MHz}$	-26 dBm	30 kHz
$3,5 \leq \Delta f < 7,5$ MHz	$4,0 \text{ MHz} \leq f_{\text{offset}} < 8,0 \text{ MHz}$	-13 dBm	1 MHz [‡]
$7,5 \leq \Delta f \leq \Delta f_{\text{max}}$ MHz	$8,0 \text{ MHz} \leq f_{\text{offset}} < f_{\text{offset}_{\text{max}}}$	P - 56 dBm	1 MHz [‡]

Table 6.6.2.1.2.3: Spectrum emission mask values, BS maximum rated output power $31 \leq PRAT < 39$ dBm

Frequency offset Δf	Frequency offset of measurement filter centre frequency, f_{offset}	Maximum level	Measurement bandwidth
$2,5 \leq \Delta f < 2,7$ MHz	$2,515 \text{ MHz} \leq f_{\text{offset}} < 2,715 \text{ MHz}$	P - 53 dBm	30 kHz [†]
$2,7 \leq \Delta f < 3,5$ MHz	$2,715 \text{ MHz} \leq f_{\text{offset}} < 3,515 \text{ MHz}$	$P - 53 - 15 \cdot (f_{\text{offset}} - 2,715)$ dBm	30 kHz [†]
	$3,515 \text{ MHz} \leq f_{\text{offset}} < 4,0 \text{ MHz}$	-26 dBm	30 kHz
$3,5 \leq \Delta f < 7,5$ MHz	$4,0 \text{ MHz} \leq f_{\text{offset}} < 8,0 \text{ MHz}$	P - 52 dBm	1 MHz [‡]
$7,5 \leq \Delta f \leq \Delta f_{\text{max}}$ MHz	$8,0 \text{ MHz} \leq f_{\text{offset}} < f_{\text{offset}_{\text{max}}}$	P - 56 dBm	1 MHz [‡]

Table 6.6.2.1.2.4: Spectrum emission mask values, BS maximum rated output power $PRAT < 31$ dBm

Frequency offset Δf	Frequency offset of measurement filter centre frequency, f_{offset}	Maximum level	Measurement bandwidth
$2,5 \leq \Delta f < 2,7$ MHz	$2,515 \text{ MHz} \leq f_{\text{offset}} < 2,715 \text{ MHz}$	-22 dBm	30 kHz [†]
$2,7 \leq \Delta f < 3,5$ MHz	$2,715 \text{ MHz} \leq f_{\text{offset}} < 3,515 \text{ MHz}$	$-22 - 15 \cdot (f_{\text{offset}} - 2,715)$ dBm	30 kHz [†]
	$3,515 \text{ MHz} \leq f_{\text{offset}} < 4,0 \text{ MHz}$	-26 dBm	30 kHz
$3,5 \leq \Delta f < 7,5$ MHz	$4,0 \text{ MHz} \leq f_{\text{offset}} < 8,0 \text{ MHz}$	-21 dBm	1 MHz [‡]
$7,5 \leq \Delta f \leq \Delta f_{\text{max}}$ MHz	$8,0 \text{ MHz} \leq f_{\text{offset}} < f_{\text{offset}_{\text{max}}}$	-25 dBm	1 MHz [‡]

Notes:

1. The first and last measurement positions with a 30 kHz filter are 2,515 MHz and 3,485 MHz.
2. The first and last measurement positions with a 1 MHz filter are 4 MHz and $(\Delta f_{\text{max}} - 500)$ kHz.

6.6.2.1.3 Test purpose

The test purpose is to verify that the BS out of band emissions do not result in undue interference to any other system (wideband, narrowband) operating at frequencies close to the assigned channel bandwidth of the wanted signal.

This test is independent of the characteristics of possible victim systems and, therefore, complements the tests on occupied bandwidth in 6.6.1 (verifying the spectral concentration of the BS Tx emissions) and on ACLR in 6.6.2.2 (simulating the perception of other UTRA receivers).

6.6.2.1.4 Method of test

6.6.2.1.4.1 Initial conditions

- (1) Connect the measuring equipment to the antenna connector of the BS under test.
- (2) Set the parameters of the BS transmitted signal according to table 6.6.2.1.4.1.1.

Table 6.6.2.1.4.1.1: Parameters of the BS transmitted signal for spectrum emission mask testing

Parameter	Value/description
TDD Duty Cycle	TS i ; $i = 0, 1, 2, \dots, 14$: transmit, if i is even; receive, if i is odd.
Base Station output power	maximum, according to Manufacturer's declaration
Number of DPCH in each active TS	9
Power of each DPCH	1/9 of Base Station output power
Data content of DPCH	real life (sufficient irregular)

6.6.2.1.4.2 Procedure

Measure the power of the BS spectrum emissions by applying measurement filters with bandwidths as specified in the relevant table in subclause 6.6.2.1.2. The characteristic of the filters shall be approximately Gaussian (typical spectrum analyzer filters). The center frequency of the filter shall be stepped in contiguous steps over the frequency bands as given in the tables. The step width shall be equal to the respective measurement bandwidth. The time duration of each step shall be sufficiently long to capture one active time slot.

For frequency offsets of the measurement filter centre frequency in the range $4.0 \text{ MHz} \leq f_{\text{offset}} < 8.0 \text{ MHz}$, the measurement shall be performed by applying filters with measurement bandwidth of 50 kHz or less and integrating the measured results over the nominal measurement bandwidth 1 MHz specified in the tables in subclause 6.6.2.1.2.1.

6.6.2.1.5 Test requirements

The spectrum emissions measured according to subclause 6.6.2.1.4.2 shall be within the mask defined in the relevant table of subclause 6.6.2.1.2.

CHANGE REQUEST

Please see embedded help file at the bottom of this page for instructions on how to fill in this form correctly.

25.142 CR 027

Current Version: **3.1.0**

GSM (AA.BB) or 3G (AA.BBB) specification number ↑

↑ CR number as allocated by MCC support team

For submission to: **RAN#8**
list expected approval meeting # here ↑

for approval
for information

strategic
non-strategic (for SMG use only)

Form: CR cover sheet, version 2 for 3GPP and SMG The latest version of this form is available from: <ftp://ftp.3gpp.org/Information/CR-Form-v2.doc>

Proposed change affects:
(at least one should be marked with an X)

(U)SIM ME UTRAN / Radio Core Network

Source: **RAN WG4** **Date:** **26.05.00**

Subject: **Test connection definition.**

Work item:

Category:

(only one category shall be marked with an X)

F Correction
A Corresponds to a correction in an earlier release
B Addition of feature
C Functional modification of feature
D Editorial modification

Release:

Phase 2
Release 96
Release 97
Release 98
Release 99
Release 00

Reason for change:

Call is too heavy process for test purpose.

Clauses affected:

6.4.2.4.1, 6.4.3.4.1, 6.4.4.4.1, 7.2.4.1, 7.3.4.1, 7.4.4.1, 7.5.4.1, 7.6.4.1,

Other specs affected:

Other 3G core specifications → List of CRs:
Other GSM core specifications → List of CRs:
MS test specifications → List of CRs:
BSS test specifications → List of CRs:
O&M specifications → List of CRs:

Other comments:

The test purpose is to verify the ability of the BS to interpret received TPC commands in a correct way and to adjust its output power according to these commands with the specified accuracy.

6.4.2.4 Method of test

6.4.2.4.1 Initial conditions

- (1) Connect the BS tester to the antenna connector of the BS under test.
- (2) Disable closed loop power control in the BS under test.
- (3) Set the initial parameters of the BS transmitted signal according to table 6.4.2.4.1.1.
- (4) Operate the BS in such a mode that it is able to interpret received TPC commands.
- ~~(4) Set up a call between the BS under test and the BS tester according to the generic call setup procedure.~~
- (5) Start BS transmission.

NOTE: The BS tester used for this test must have the ability

- to analyze the output signal of the BS under test with respect to code domain power, by applying the global in-channel Tx test method described in Annex C;
- to simulate an UE with respect to the generation of TPC commands embedded in a valid UE signal.

Table 6.4.2.4.1.1: Initial parameters of the BS transmitted signal for power control steps test

Parameter	Value/description
TDD Duty Cycle	TS i ; $i = 0, 1, 2, \dots, 14$: transmit, if i is even; receive, if i is odd.
Number of DPCH in each active TS	1
DPCH power	Minimum
Data content of DPCH	real life (sufficient irregular)

6.4.2.4.2 Procedure

- (1) Configure the BS transmitter to enable power control steps of size 1 dB.
- (2) Set the BS tester to produce a sequence of TPC commands related to the active DPCH. This sequence shall be transmitted to the BS within the odd time slots TS i (receive time slots of the BS) and shall consist of a series of TPC commands with content "Increase Tx power", followed by a series of TPC commands with content "Decrease Tx power". Each of these series should be sufficiently long so that the transmit output power of the active DPCH is controlled to reach its maximum and its minimum, respectively.
- (3) Measure the power of the active DPCH over the 2464 active chips of each even time slot TS i (-this excludes the guard period), , and with a measurement filter that has a RRC filter response with a roll off $\alpha = 0,22$ and a bandwidth equal to the chip rate. The power is determined by calculating the RMS value of the signal samples at the measurement filter output taken at the decision points.
- (4) Based on the measurement made in step (3), calculate the power control step sizes and the average rate of change per 10 steps.
- (5) Configure the BS transmitter to enable power control steps of 2 dB and of 3 dB, respectively, and repeat steps (2) to (4).

NOTE: In case of power control step size 3 dB, the number of power control steps feasible within the power control dynamic range of the BS under test may be lower than 10. In this case, the evaluation of the average rate of change in mean power may be based on less than 10 power control steps.

6.4.2.5 Test requirements

For all measurements, the tolerance of the power control step sizes and the average rate of change per 10 steps shall be within the limits given in Table 6.4.2.2.1.

6.4.3 Power control dynamic range

6.4.3.1 Definition and applicability

The power control dynamic range is the difference between the maximum and the minimum transmit output power for a specified reference condition.

The requirements in this subclause shall apply to base stations intended for general-purpose applications.

6.4.3.2 Conformance requirements

The DL power control dynamic range shall be greater than or equal to 30 dB.

The reference for this requirement is TS 25.105 subclause 6.4.3.1.

6.4.3.3 Test purpose

The test purpose is to verify the ability of the BS to control the power of a single code signal over the specified dynamic range.

6.4.3.4 Method of test

6.4.3.4.1 Initial conditions

- (1) Connect the BS tester to the antenna connector of the BS under test.
- (2) Set the parameters of the BS transmitted signal according to table 6.4.3.4.1.1.
- (3) Operate the BS in such a mode that it is able to interpret received TPC commands
- ~~(3) Set up a call between the BS under test and the BS tester according to the generic call setup procedure.~~
- (4) Start BS transmission.

NOTE: The BS tester used for this test must have the ability

- to analyze the output signal of the BS under test with respect to code domain power, by applying the global in-channel Tx test method described in Annex C;

- to simulate an UE with respect to the generation of TPC commands embedded in a valid UE signal.

Table 6.4.3.4.1.1: Parameters of the BS transmitted signal for power control dynamic range test

Parameter	Value/description
TDD Duty Cycle	TS i ; $i = 0, 1, 2, \dots, 14$: transmit, if i is even; receive, if i is odd.
Number of DPCH in each active TS	1
Data content of DPCH	real life (sufficient irregular)

6.4.3.4.2 Procedure

- (1) Configure the BS transmitter to enable power control steps of size 1 dB.

- (2) Set the BS tester to produce a sequence of TPC commands related to the active DPCH, with content "Increase Tx power". This sequence shall be sufficiently long so that the transmit output power of the active DPCH is controlled to reach its maximum, and shall be transmitted to the BS within the odd time slots TS i (receive time slots of the BS).
- (3) Measure the power of the active DPCH over the 2464 active chips of each even time slot TS i (this excludes the guard period), and with a measurement filter that has a RRC filter response with a roll off $\alpha = 0,22$ and a bandwidth equal to the chip rate. The power is determined by calculating the RMS value of the signal samples at the measurement filter output taken at the decision points.
- (4) Average over TBD time slots.
- (5) Set the BS tester to produce a sequence of TPC commands related to the active DPCH, with content "Decrease Tx power". This sequence shall be sufficiently long so that the transmit output power of the active DPCH is controlled to reach its minimum, and shall be transmitted to the BS within the odd time slots TS i (receive time slots of the BS).
- (6) Measure the power of the active DPCH over the 2464 active chips of each even time slot TS i (this excludes the guard period), and with a measurement filter that has a RRC filter response with a roll off $\alpha = 0,22$ and a bandwidth equal to the chip rate. The power is determined by calculating the RMS value of the signal samples at the measurement filter output taken at the decision points.
- (7) Average over TBD time slots.
- (8) Calculated the power control dynamic range difference between the maximum transmit output power measured in steps (3) and (4) and the minimum transmit output power measured in steps (6) and (7).
- (9) Configure the BS transmitter to enable power control steps of 2 dB and of 3 dB, respectively, and repeat steps (2) to (8).

6.4.3.5 Test requirements

The power control dynamic range derived according to 6.4.3.4.2 shall be in compliance with the requirements in 6.4.3.2.

6.4.4 Minimum transmit power

6.4.4.1 Definition and applicability

The minimum controlled output power of the BS is when the power control setting is set to a minimum value. This is when the power control indicates a minimum transmit output power is required.

The requirements in this subclause shall apply to base stations intended for general-purpose applications.

6.4.4.2 Conformance requirements

The DL minimum transmit power shall be lower than or equal to

$$\text{Maximum output power} - 30 \text{ dB.}$$

The reference for this requirement is TS 25.105 subclause 6.4.4.1.

6.4.4.3 Test purpose

The test purpose is to verify the ability of the BS to reduce its output power to a specified value.

6.4.4.4 Method of test

6.4.4.4.1 Initial conditions

- (1) Connect the BS tester to the antenna connector of the BS under test.

- (2) Set the parameters of the BS transmitted signal according to table 6.4.4.4.1.1.
- (3) Operate the BS in such a mode that it is able to interpret received TPC commands
- ~~(3) Set up a call between the BS under test and the BS tester according to the generic call setup procedure.~~
- (4) Start BS transmission.

NOTE: The BS tester used for this test must have the ability

- to analyze the output signal of the BS under test with respect to thermal power;
- to simulate an UE with respect to the generation of TPC commands embedded in a valid UE signal.

Table 6.4.4.4.1.1: Parameters of the BS transmitted signal for minimum transmit power test

Parameter	Value/description
TDD Duty Cycle	TS i ; $i = 0, 1, 2, \dots, 14$: transmit, if i is even; receive, if i is odd.
Number of DPCH in each active TS	9
Power of each DPCH	1/9 of Base Station output power
Data content of DPCH	real life (sufficient irregular)

6.4.4.4.2 Procedure

- (1) Configure the BS transmitter to enable power control steps of size 1 dB.
- (2) Set the BS tester to produce a sequence of TPC commands related to all active DPCH, with content "Decrease Tx power". This sequence shall be sufficiently long so that the transmit output power of all active DPCH is controlled to reach its minimum, and shall be transmitted to the BS within the odd time slots TS i (receive time slots of the BS).
- (3) Measure the power of the BS output signal over the 2464 active chips of each even time slot TS i (this excludes the guard period), and with a measurement filter that has a RRC filter response with a roll off $\alpha = 0,22$ and a bandwidth equal to the chip rate. The power is determined by calculating the RMS value of the signal samples at the measurement filter output taken at the decision points.
- (4) Average over TBD time slots.
- (5) Configure the BS transmitter to enable power control steps of 2 dB and of 3 dB, respectively, and repeat steps (2) to (4).

6.4.4.5 Test requirements

For all measurements, the minimum transmit power derived in step (4) of 6.4.4.4.2 shall be at least 30 dB below the maximum output power as declared by the manufacturer; see 6.2.

6.4.5 Primary CCPCH power

6.4.5.1 Definition and applicability

Primary CCPCH power is the transmission power of the Primary Common Control Physical Channel averaged over the transmit timeslot. Primary CCPCH power is signaled on the BCH.

The requirements in this subclause shall apply to base stations intended for general-purpose applications.

6.4.5.2 Conformance requirements

The error between the BCH-broadcast value of the Primary CCPCH power and the Primary CCPCH power shall not exceed the values in table 6.4.5.2.1.

7 Receiver characteristics

7.1 General

All tests unless otherwise stated in this subclause shall be conducted on Base Station Systems fitted with a full complement of Transceivers for the configuration. The manufacturer shall provide appropriate logical or physical test access to perform all tests in this subclause. Measurements shall include any RX multicoupler.

The tests in clause 7 assume that the receiver is not equipped with diversity. For receivers with diversity, the tests may be performed by applying the specified signals to one of the receiver inputs, and terminating or disabling the other(s). The tests and requirements are otherwise unchanged.

For receivers with diversity, testing of conformance shall be performed by applying the specified signals to one of the receiver inputs, and terminating or disabling the other(s).

In all the relevant subclauses in this clause all Bit Error Ratio (BER), Residual BER (RBER) and Frame Erasure Ratio (FER) measurements shall be carried out according to the general rules for statistical testing.

Unless detailed the receiver characteristic are specified at each antenna connector of the BS.

7.2 Reference sensitivity level

7.2.1 Definition and applicability

The reference sensitivity is the minimum receiver input power measured at the antenna connector at which the BER does not exceed the specific value.

The requirements in this subclause shall apply to base stations intended for general-purpose applications.

7.2.2 Conformance requirements

For the measurement channel specified in Annex A.2.1, the reference sensitivity level and performance of the BS shall be as specified in table 7.2.2.1 below.

Table 7.2.2.1: BS reference sensitivity levels

Data rate	BS reference sensitivity level (dBm)	BER
12,2 kbps	-109 dBm	BER shall not exceed 0,001

The reference for this requirement is TS 25.105 subclause 7.2.1.

7.2.3 Test purpose

The test purpose is to verify the ability of the BS to receive a prescribed single-code test signal of minimum input power under defined conditions (no interference, no multipath propagation) with a BER not exceeding a specified limit. This test is also used as a reference case for other tests to allow the assessment of degradations due to various sources of interference.

7.2.4 Method of test

7.2.4.1 Initial conditions

- (1) Connect the BS tester (UE simulator) to the antenna connector of one BS Rx port.
- (2) Terminate any other BS Rx port not under test.

- (3) ~~Set up a call between the BS tester and the BS. The characteristics of the call shall be according to the 12,2 kbit/s UL reference measurement channel specified in Annex A.2.1.~~
- (3) Start transmission from the BS tester to the BS using the UL reference measurement channel (12.2 kbps) defined in Annex A.2.1.
- (4) The level of BS tester output signal measured at the BS antenna connector shall be adjusted to -109 dBm.

7.2.4.2 Procedure

- (1) Measure the BER by comparing the bit sequence of the information data transmitted by the BS tester with the bit sequence obtained from the BS receiver.
- (2) Interchange the connections of the BS Rx ports and repeat the measurement according to (1).

7.2.5 Test requirements

For any BS Rx port tested, the measured BER shall not exceed 0,001.

7.3 Dynamic range

7.3.1 Definition and applicability

The receiver dynamic range is the input power range at each BS antenna connector over which the BER does not exceed a specified value.

The requirements in this subclause shall apply to base stations intended for general-purpose applications.

7.3.2 Conformance requirements

The static BER reference performance as specified in subclause 7.2 shall be met over a receiver input range of 30 dB above the specified reference sensitivity level for the 12,2 kbit/s channel.

The reference for this requirement is TS 25.105 subclause 7.3.

7.3.3 Test purpose

The test purpose is to verify the ability of the BS to receive a prescribed single-code test signal of maximum input power under defined conditions (no interference, no multipath) with a BER not exceeding a specified limit.

7.3.4 Method of test

7.3.4.1 Initial conditions

- (1) Connect the BS tester (UE simulator) to the antenna connector of one BS Rx port.
- (2) Terminate any other BS Rx port not under test.
- (3) ~~Set up a call between the BS tester and the BS. The characteristics of the call shall be according to the 12,2 kbit/s UL reference measurement channel specified in Annex A.2.1.~~
- (3) Start transmission from the BS tester to the BS using the UL reference measurement channel (12.2 kbps) defined in Annex A.2.1.
- (4) The level of the BS tester output signal measured at the BS antenna connector shall be adjusted to $(-110 + 30)$ dBm.

7.3.4.2 Procedure

- (1) Measure the BER by comparing the bit sequence of the information data transmitted by the BS tester with the bit sequence obtained from the BS receiver.

- (2) Interchange the connections of the BS Rx ports and repeat the measurement according to (1)

7.3.5 Test requirements

For any BS Rx port tested, the measured BER shall not exceed 0,001.

7.4 Adjacent Channel Selectivity (ACS)

7.4.1 Definition and applicability

Adjacent channel selectivity (ACS) is a measure of the receiver ability to receive a wanted signal at its assigned channel frequency in the presence of an adjacent channel signal at a given frequency offset from the center frequency of the assigned channel.

The requirements in this subclause shall apply to base stations intended for general-purpose applications.

7.4.2 Conformance requirements

The BER, measured on the wanted signal in the presence of an interfering signal, shall not exceed 0,001 for the parameters specified in table 7.4.2.2.1.

Table 7.4.2.2.1: Parameters of the wanted signal and the interfering signal for ACS testing

Parameter	Level	Unit
Data rate	12,2	kbit/s
Wanted signal	Reference sensitivity level + 6 dB	dBm
Interfering signal	-52	dBm
F _w (modulated)	5	MHz
NOTE: F _w is the frequency offset of the unwanted interfering signal from the assigned channel frequency of the wanted signal.		

The reference for this requirement is TS 25.105 subclause 7.4.1.

7.4.3 Test purpose

The test purpose is to verify the ability of the BS receiver filter to sufficiently suppress interfering signals in the channels adjacent to the wanted channel.

7.4.4 Method of test

7.4.4.1 Initial conditions

- (1) Connect an UE simulator operating at the assigned channel frequency of the wanted signal and a signal generator used to produce the interfering signal in the adjacent channel to the antenna connector of one Rx port.
- (2) Terminate any other Rx port not under test.
- (3) ~~Set up a call between the UE simulator and the BS tester. The characteristics of the call shall be set according to the UL reference measurement channel (12,2 kbit/s) specified in Annex A.2.1. The level of the UE simulator signal measured at the BS antenna connector shall be adjusted to the value specified in table 7.4.2.2.1.~~
- (3) Start transmission from the BS tester to the BS using the UL reference measurement channel (12.2 kbps) defined in Annex A.2.1. The level of the UE simulator signal measured at the BS antenna connector shall be adjusted to the value specified in table 7.4.2.2.1.
- (4) Set the signal generator to produce an interfering signal that is equivalent to a continuous wideband CDMA signal with one code of chip frequency 3,84 Mchip/s, filtered by an RRC transmit pulse-shaping filter with roll-off

$\alpha = 0,22$. The level of the interfering signal measured at the BS antenna connector shall be adjusted to the value specified in table 7.4.2.2.1.

7.4.4.2 Procedure

- (1) Set the center frequency of the interfering signal to 5 MHz above the assigned channel frequency of the wanted signal.
- (2) Measure the BER of the wanted signal at the BS receiver.
- (3) Set the center frequency of the interfering signal to 5 MHz below the assigned channel frequency of the wanted signal.
- (4) Measure the BER of the wanted signal at the BS receiver.
- (5) Interchange the connections of the BS Rx ports and repeat the measurements according to steps (1) to (4).

7.4.5 Test requirements

The BER measured according subclause 7.4.4.2 to shall not exceed 0,001.

7.5 Blocking characteristics

7.5.1 Definition and applicability

The blocking characteristics is a measure of the receiver ability to receive a wanted signal at its assigned channel frequency in the presence of an unwanted interferer on frequencies other than those of the adjacent channels. The blocking performance shall apply at all frequencies as specified in tables 7.5.2.1 or 7.5.2.2, respectively, using a 1 MHz step size.

The requirements in this subclause shall apply to base stations intended for general-purpose applications.

7.5.2 Conformance requirements

The static reference performance as specified in clause 7.2 should be met with a wanted and an interfering signal coupled to the BS antenna input using the parameters specified in tables 7.5.2.1 or 7.5.2.2, respectively.

Table 7.5.2.1: Blocking requirements for operating bands defined in subclause 4.2 a)

Center frequency of interfering signal	Interfering signal level	Wanted signal level	Minimum offset of interfering signal	Type of interfering signal
1900 – 1920 MHz, 2010 – 2025 MHz	-40 dBm	<REFSENS> + 6 dB	10 MHz	WCDMA signal with one code
1880 – 1900 MHz, 1990 – 2010 MHz, 2025 – 2045 MHz	-40 dBm	<REFSENS> + 6 dB	10 MHz	WCDMA signal with one code
1920 – 1980 MHz	-40 dBm	<REFSENS> + 6 dB	10 MHz	WCDMA signal with one code
1 - 1880 MHz, 1980 – 1990 MHz, 2045 – 12750 MHz	-15 dBm	<REFSENS> + 6 dB	—	CW carrier

Table 7.5.2.2: Blocking requirements for operating bands defined in subclause 4.2 b), c)

Center frequency of interfering signal	Interfering signal level	Wanted signal level	Minimum offset of interfering signal	Type of interfering signal
1850 – 1990 MHz	-40 dBm	<REFSENS> + 6 dB	10 MHz	WCDMA signal with one code
1830 – 1850 MHz, 1990 – 2010 MHz	-40 dBm	<REFSENS> + 6 dB	10 MHz	WCDMA signal with one code

53

1 – 1830 MHz, 2045 – 12750 MHz	-15 dBm	<REFSENS> + 6 dB	—	CW carrier
-----------------------------------	---------	------------------	---	------------

The reference for this requirement is TS 25.105 subclause 7.5.

7.5.3 Test purpose

The test stresses the ability of the BS receiver to withstand high-level interference from unwanted signals at frequency offsets of 10 MHz or more, without undue degradation of its sensitivity.

7.5.4 Method of test

7.5.4.1 Initial conditions

- (1) Connect an UE simulator operating at the assigned channel frequency of the wanted signal and a signal generator to the antenna connector of one Rx port.
- (2) Terminate any other Rx port not under test.
- (3) ~~Set up a call between the UE simulator and the BS tester. The characteristics of the call shall be set according to the UL reference measurement channel (12,2 kbit/s) specified in Annex A.2.1. The level of the UE simulator signal measured at the BS antenna connector shall be set to 6 dB above the reference sensitivity level specified in subclause 7.2.2.~~
- (3) Start transmission from the BS tester to the BS using the UL reference measurement channel (12.2 kbps) defined in Annex A.2.1. The level of the UE simulator signal measured at the BS antenna connector shall be set to 6 dB above the reference sensitivity level specified in subclause 7.2.2.

7.5.4.2 Procedure

- (1) Set the signal generator to produce an interfering signal at a frequency offset F_{uw} from the assigned channel frequency of the wanted signal which is given by

$$F_{uw} = \pm (n \times 1 \text{ MHz}),$$

where n shall be increased in integer steps from $n = 10$ up to such a value that the center frequency of the interfering signal covers the range from 1 MHz to 12,75 GHz. The interfering signal level measured at the antenna connector shall be set in dependency of its center frequency, as specified in tables 7.5.2.1 or 7.5.2.2, respectively. The type of the interfering signal is either equivalent to a continuous wideband CDMA signal with one code of chip frequency 3,84 Mchip/s, filtered by an RRC transmit pulse-shaping filter with roll-off $\alpha = 0,22$, or a CW signal; see tables 7.5.2.1 or 7.5.2.2, respectively.

- (2) Measure the BER of the wanted signal at the BS receiver.
- (3) Interchange the connections of the BS Rx ports and repeat the measurements according to steps (1) and (2).

NOTE: The test procedure as defined in steps (1) and (2) requests to carry out more than 10000 BER measurements. To reduce the time needed for these measurements, it may be appropriate to conduct the test in two phases: During phase 1, BER measurements are made on all center frequencies of the interfering signal as requested but with a reduced confidence level, with the aim to identify those frequencies which require more detailed investigation. In phase 2, detailed measurements are made only at those critical frequencies identified before, applying the required confidence level.

7.5.5 Test requirements

In all measurements made according to subclause 7.5.4.2, the BER shall not exceed 0,001.

7.6 Intermodulation characteristics

7.6.1 Definition and applicability

Third and higher order mixing of two interfering RF signals can produce an interfering signal in the band of the desired channel. Intermodulation response rejection is a measure of the capability of the receiver to receive a wanted signal on its assigned channel frequency in the presence of two or more interfering signals which have a specific frequency

54

relationship to the wanted signal.

The requirements in this subclause shall apply to base stations intended for general-purpose applications.

7.6.2 Conformance requirements

The static reference performance as specified in clause 7.2 should be met when the following signals are coupled to the BS antenna input.

- A wanted signal at the assigned channel frequency, 6 dB above the static reference level.
- Two interfering signals with the parameters specified in table 7.6.2.1.

Table 7.6.2.1: Parameters of the interfering signals for intermodulation characteristics testing

Interfering Signal Level	Offset	Type of Interfering Signal
- 48 dBm	10 MHz	CW signal
- 48 dBm	20 MHz	WCDMA signal with one code

The reference for this requirement is TS 25.105 subclause 7.6.

7.6.3 Test purpose

The test purpose is to verify the ability of the BS receiver to inhibit the generation of intermodulation products in its non-linear elements caused by the presence of two high-level interfering signals at frequencies with a specific relationship to the frequency of the wanted signal.

7.6.4 Method of test

7.6.4.1 Initial conditions

- (1) Connect an UE simulator operating at the assigned channel frequency of the wanted signal and two signal generators to the antenna connector of one Rx port.
- (2) Terminate any other Rx port not under test.
- (3) ~~Set up a call between the UE simulator and the BS tester. The characteristics of the call shall be set according to the UL reference measurement channel (12,2 kbit/s) specified in Annex A.2.1. The level of the UE simulator signal measured at the BS antenna connector shall be set to 6 dB above the reference sensitivity level specified in subclause 7.2.2.~~
- (3) Start transmission from the BS tester to the BS using the UL reference measurement channel (12.2 kbps) defined in Annex A.2.1. The level of the UE simulator signal measured at the BS antenna connector shall be set to 6 dB above the reference sensitivity level specified in subclause 7.2.2.
- (4) Set the first signal generator to produce a CW signal with a level measured at the BS antenna connector of - 48 dBm.

- (5) Set the second signal generator to produce an interfering signal equivalent to a wideband CDMA signal with one code of chip frequency 3,84 Mchip/s, filtered by an RRC transmit pulse-shaping filter with roll-off $\alpha = 0,22$. The level of the signal measured at the BS antenna connector shall be set to - 48 dBm.

7.6.4.2 Procedure

- (1) The frequency of the first and the second signal generator shall be set to 10 MHz and 20 MHz, respectively, above the assigned channel frequency of the wanted signal.
- (2) Measure the BER of the wanted signal at the BS receiver.
- (3) The frequency of the first and the second signal generator shall be set to 10 MHz and 20 MHz, respectively, below the assigned channel frequency of the wanted signal.
- (4) Measure the BER of the wanted signal at the BS receiver.
- (5) Interchange the connections of the BS Rx ports and repeat the measurements according to steps (1) to (4).

7.6.5 Test requirements

The BER measured according subclause 7.6.4.2 to shall not exceed 0,001.