

TS 25.331 V1.5.0 (1999-09)

Technical Specification

TSG-RP#5(99)468

TSG-RAN meeting #5
6th – 8th October 1999

3rd Generation Partnership Project (3GPP); Technical Specification Group (TSG) RAN; Working Group 2 (WG2);

RRC Protocol Specification

Kyongju, Sweden



The present document has been developed within the 3rd Generation Partnership Project (3GPPTM) and may be further elaborated for the purposes of 3GPP.

The present document has not been subject to any approval process by the 3GPP Organisational Partners and shall not be implemented.

This Specification is provided for future development work within 3GPP only. The Organisational Partners accept no liability for any use of this Specification.

Specifications and reports for implementation of the 3GPPTM system should be obtained via the 3GPP Organisational Partners' Publications Offices.

Reference

<Workitem> (<Shortfilename>.PDF)

Keywords

<keyword[, keyword]>

3GPP

Postal address

Office address

Internet

secretariat@3gpp.org
Individual copies of this deliverable
can be downloaded from
<http://www.3gpp.org>

Copyright Notification

No part may be reproduced except as authorized by written permission.
The copyright and the foregoing restriction extend to reproduction in all media.

©
All rights reserved.

Contents

1. SCOPE	1516
2. REFERENCES	1516
3. DEFINITIONS, SYMBOLS AND ABBREVIATIONS	1516
3.1 DEFINITIONS	1516
3.2 ABBREVIATIONS	1516
4. GENERAL	1718
5 RRC SERVICES PROVIDED TO UPPER LAYERS	1920
6 SERVICES EXPECTED FROM LOWER LAYERS	1920
6.1 SERVICES EXPECTED FROM LAYER 2	1920
6.2 SERVICES EXPECTED FROM LAYER 1	1920
7 FUNCTIONS OF RRC	2021
8 RRC PROCEDURES	2122
8.1 RRC CONNECTION MANAGEMENT PROCEDURES	2122
8.1.1 <i>Broadcast of system information</i>	2122
8.1.1.1 General	2122
8.1.1.1.1 System information structure	2122
8.1.1.1.2 Acquisition of system information blocks.....	2223
8.1.1.1.3 Scheduling of system information.....	2223
8.1.1.2 Initiation	2224
8.1.1.3 Reception of SYSTEM INFORMATION by the UE	2324
8.1.1.3.1 Reception of SYSTEM INFORMATION broadcast on a BCH transport channel	2324
8.1.1.3.2 Reception of SYSTEM INFORMATION broadcast on a FACH transport channel.....	2324
8.1.1.4 Modification of system information	2324
8.1.1.4.1 Modification of system information blocks using a value tag.....	2324
8.1.1.4.2 Modification of system information blocks containing an expiration time.....	2425
8.1.2 <i>Paging</i>	2425
8.1.2.1 General	2425
8.1.2.2 Initiation	2425
8.1.2.2.1 Message PAGING TYPE 1 contents to set.....	2426
8.1.2.3 Reception of message PAGING TYPE 1 by the UE.....	2526
8.1.2.3.1 Message PAGING TYPE 1 contents to use	2526
8.1.3 <i>RRC connection establishment</i>	2526
8.1.3.1 General	2627
8.1.3.2 Initiation	2627
8.1.3.2.1 Message RRC CONNECTION REQUEST contents to set.....	2627
8.1.3.3 Reception of RRC CONNECTION REQUEST by the UTRAN	2627
8.1.3.3.1 Message RRC CONNECTION SETUP contents to set	2627
8.1.3.3.2 Message RRC CONNECTION REJECT contents to set	2627
8.1.3.4 Reception of RRC CONNECTION SETUP by the UE.....	2627
8.1.3.4.1 Message RRC CONNECTION SETUP contents to use	2728
8.1.3.4.2 Message RRC CONNECTION SETUP COMPLETE contents to set	2728
8.1.3.5 Abnormal cases: Physical channel failure or T300 timeout.....	2728
8.1.3.6 Reception of RRC CONNECTION REJECT by the UE.....	2728
8.1.3.6.1 Message RRC CONNECTION REJECT contents to use	2728
8.1.3.7 Reception of RRC CONNECTION SETUP COMPLETE by the UTRAN.....	2829
8.1.3.8 Abnormal case: T350 timeout.....	2829
8.1.4 <i>RRC connection release</i>	2829
8.1.4.1 General	2829
8.1.4.2 Initiation	2829
8.1.4.2.1 Retransmission of message RRC CONNECTION RELEASE.....	2829
8.1.4.3 Reception of RRC CONNECTION RELEASE by the UE.....	2829
8.1.4.3.1 Message RRC CONNECTION RELEASE contents to use	2930
8.1.4.4 CELL_DCH: Expiry of timer T308	2930

8.1.4.5	CELL_FACH: Successful transmission of RRC CONNECTION RELEASE COMPLETE.....	2930
8.1.4.6	Reception of RRC CONNECTION RELEASE COMPLETE by UTRAN.....	2930
8.1.4.7	CELL_FACH abnormal case: unsuccessful transmission of RRC CONNECTION RELEASE COMPLETE.....	2930
8.1.4.8	CELL_DCH abnormal case: detection of dedicated physical channel release by UTRAN.....	2930
8.1.4.9	Abnormal case: no reception of RRC CONNECTION RELEASE COMPLETE by UTRAN.....	2930
8.1.5	<i>RRC connection re-establishment</i>	2930
8.1.5.1	General.....	3031
8.1.5.2	Initiation.....	3031
8.1.5.2.1	Message RRC CONNECTION RE-ESTABLISHMENT REQUEST contents to set.....	3031
8.1.5.3	Reception of RRC CONNECTION RE-ESTABLISHMENT REQUEST by the UTRAN.....	3031
8.1.5.3.1	Message RRC CONNECTION RE-ESTABLISHMENT contents to set.....	3031
8.1.5.3.2	Message RRC CONNECTION RELEASE contents to set.....	3032
8.1.5.4	Reception of RRC CONNECTION RE-ESTABLISHMENT by the UE.....	3132
8.1.5.4.1	Message RRC CONNECTION RE-ESTABLISHMENT contents to use.....	3132
8.1.5.4.2	Message RRC CONNECTION RE-ESTABLISHMENT COMPLETE contents to set.....	3133
8.1.5.5	Abnormal cases: T301 timeout or DPCH failure.....	3133
8.1.5.6	Reception of RRC CONNECTION RE-ESTABLISHMENT COMPLETE by the UTRAN.....	3233
8.1.5.7	Abnormal case: T352 timeout.....	3233
8.1.6	<i>Transmission of UE capability information</i>	3233
8.1.6.1	General.....	3233
8.1.6.2	Initiation.....	3233
8.1.6.2.1	Message UE CAPABILITY INFORMATION contents to set.....	3234
8.1.6.3	Reception of UE CAPABILITY INFORMATION by the UTRAN.....	3334
8.1.6.3.1	Message UE CAPABILITY INFORMATION contents to use.....	3334
8.1.6.3.2	Message UE CAPABILITY INFORMATION CONFIRM contents to set.....	3334
8.1.6.4	Reception of UE CAPABILITY INFORMATION CONFIRM by the UE.....	3334
8.1.6.5	Abnormal case: T304 timeout.....	3334
8.1.7	<i>UE capability enquiry</i>	3335
8.1.7.1	General.....	3435
8.1.7.2	Initiation.....	3435
	Message UE CAPABILITY ENQUIRY contents to set.....	3435
8.1.7.3	Reception of message UE CAPABILITY ENQUIRY by the UE.....	3435
8.1.7.4	Abnormal case.....	3435
8.1.8	<i>Direct transfer</i>	3435
8.1.8.1	General.....	3536
8.1.8.2	Initiation of direct transfer procedure in the UE.....	3536
8.1.8.2.1	Message DIRECT TRANSFER (uplink) contents to set.....	3536
8.1.8.3	Initiation of direct transfer procedure in the UTRAN.....	3536
8.1.8.3.1	Message DIRECT TRANSFER (downlink) contents to set.....	3536
8.1.8.4	Reception of DIRECT TRANSFER in the UTRAN.....	3536
8.1.8.4.1	Message DIRECT TRANSFER (uplink) contents to use.....	3537
8.1.8.5	Reception of DIRECT TRANSFER by the UE.....	3537
8.1.8.5.1	Message DIRECT TRANSFER (downlink) contents to use.....	3537
8.1.8.6	Abnormal cases.....	3537
8.1.9	<i>Connected mode paging on DCCH</i>	3537
8.1.9.1	General.....	3637
8.1.9.2	Initiation.....	3637
8.1.9.2.1	Message PAGING TYPE 2 contents to set.....	3637
8.1.9.3	Reception of message PAGING TYPE 2 by the UE.....	3637
8.1.10	<i>Security mode control</i>	3637
8.2	RADIO BEARER CONTROL PROCEDURES	3839
8.2.1	<i>Radio bearer establishment</i>	3839
8.2.1.1	General.....	3839
8.2.1.2	Initiation.....	3839
8.2.1.2.1	Message RADIO BEARER SETUP contents to set.....	3839
8.2.1.3	Reception of RADIO BEARER SETUP by the UE.....	3940
8.2.1.3.1	Message RADIO BEARER SETUP contents to use.....	3940
8.2.1.3.2	Message RADIO BEARER SETUP COMPLETE contents to set.....	3940
8.2.1.4	Abnormal case: Unsupported configuration in the UE.....	3940
8.2.1.4.1	Message RADIO BEARER SETUP FAILURE contents to set.....	3940
8.2.1.5	Abnormal cases: Physical channel failure.....	3940
8.2.1.5.1	Message RADIO BEARER SETUP FAILURE contents to set.....	4041
8.2.1.6	Reception of RADIO BEARER SETUP COMPLETE by the UTRAN.....	4041
8.2.1.7	Reception of RADIO BEARER SETUP FAILURE by the UTRAN.....	4041
8.2.1.8	Abnormal case: T353 timeout.....	4041
8.2.2	<i>Radio bearer reconfiguration</i>	4041

8.2.2.1	General	4041
8.2.2.2	Initiation	4142
8.2.2.2.1	Message RADIO BEARER RECONFIGURATION contents to set	4142
8.2.2.3	Reception of RADIO BEARER RECONFIGURATION by the UE in CELL_DCH state.....	4142
8.2.2.3.1	Message RADIO BEARER RECONFIGURATION contents to use in CELL_DCH state	4142
8.2.2.3.2	Message RADIO BEARER RECONFIGURATION COMPLETE contents to set in CELL_DCH state	4243
8.2.2.4	Reception of RADIO BEARER RECONFIGURATION by the UE in CELL_FACH state.....	4243
8.2.2.4.1	Message RADIO BEARER RECONFIGURATION contents to use in CELL_FACH state.....	4243
8.2.2.4.2	Message RADIO BEARER RECONFIGURATION COMPLETE contents to set in CELL_FACH state	4243
8.2.2.5	Reception of RADIO BEARER RECONFIGURATION COMPLETE by the UTRAN	4244
8.2.2.6	Abnormal case: Unsupported configuration in the UE	4344
8.2.2.6.1	Message RADIO BEARER RECONFIGURATION FAILURE contents to set.....	4344
8.2.2.7	Abnormal case: Physical channel failure	4344
8.2.2.7.1	Message RADIO BEARER RECONFIGURATION FAILURE contents to set.....	4344
8.2.2.8	Reception of RADIO BEARER RECONFIGURATION FAILURE by the UTRAN	4344
8.2.2.9	Abnormal case: T355 timeout in CELL_DCH state	4344
8.2.2.10	Abnormal case: T355 timeout in CELL_FACH state.....	4344
8.2.2.11	Abnormal case: physical channel failure during transition from CELL_DCH to CELL_FACH.....	4345
8.2.2.12	Abnormal case: Suspension of signalling bearer	4345
8.2.3	<i>Radio bearer release</i>	4445
8.2.3.1	Purpose	4445
8.2.3.2	Initiation	4445
8.2.3.2.1	Message RADIO BEARER RELEASE contents to set.....	4445
8.2.3.3	Reception of RADIO BEARER RELEASE by the UE	4546
8.2.3.3.1	Message RADIO BEARER RELEASE contents to use.....	4546
8.2.3.3.2	Message RADIO BEARER RELEASE COMPLETE contents to set.....	4547
8.2.3.4	Abnormal case: Unsupported configuration in the UE	4547
8.2.3.4.1	Message RADIO BEARER RELEASE FAILURE contents to set.....	4547
8.2.3.5	Abnormal cases: Physical channel failure.....	4647
8.2.3.5.1	Message RADIO BEARER RELEASE FAILURE contents to set.....	4647
8.2.3.6	Reception of RADIO BEARER RELEASE COMPLETE by the UTRAN	4647
8.2.3.7	Reception of RADIO BEARER RELEASE FAILURE by the UTRAN.....	4647
8.2.3.8	Abnormal case: T354 timeout.....	4647
8.2.3.9	Abnormal case: physical channel failure during transition from CELL_DCH to CELL_FACH.....	4647
8.2.4	<i>Transport channel reconfiguration</i>	4648
8.2.4.1	General	4748
8.2.4.2	Initiation	4748
8.2.4.2.1	Message TRANSPORT CHANNEL RECONFIGURATION contents to set.....	4748
8.2.4.3	Reception of TRANSPORT CHANNEL RECONFIGURATION by the UE in CELL_DCH state	4748
8.2.4.3.1	Message TRANSPORT CHANNEL RECONFIGURATION contents to use in CELL_DCH state	4749
8.2.4.3.2	Message TRANSPORT CHANNEL RECONFIGURATION COMPLETE contents to set in CELL_DCH state	4849
8.2.4.4	Reception of TRANSPORT CHANNEL RECONFIGURATION by the UE in CELL_FACH state.....	4849
8.2.4.4.1	Message TRANSPORT CHANNEL RECONFIGURATION contents to use in CELL_FACH state	4849
8.2.4.4.2	Message TRANSPORT CHANNEL RECONFIGURATION COMPLETE contents to set in CELL_FACH state	4850
8.2.4.5	Reception of TRANSPORT CHANNEL RECONFIGURATION COMPLETE by the UTRAN	4850
8.2.4.6	Abnormal case: Unsupported configuration in the UE	4950
8.2.4.6.1	Message TRANSPORT CHANNEL RECONFIGURATION FAILURE contents to set.....	4950
8.2.4.7	Abnormal case: Physical channel failure	4950
8.2.4.7.1	Message TRANSPORT CHANNEL RECONFIGURATION FAILURE contents to set	4950
8.2.4.8	Reception of TRANSPORT CHANNEL RECONFIGURATION FAILURE by the UTRAN.....	4950
8.2.4.9	Abnormal case: T356 timeout in CELL_DCH state	4950
8.2.4.10	Abnormal case: T356 timeout in CELL_FACH state.....	4951
8.2.4.11	Abnormal case: physical channel failure during transition from CELL_DCH to CELL_FACH.....	4951
8.2.5	<i>Transport format combination control</i>	5051
8.2.5.1	General	5051
8.2.5.2	Initiation	5051
8.2.5.2.1	Message TRANSPORT CHANNEL COMBINATION CONTROL contents to set.....	5051
8.2.5.3	Reception of TRANSPORT CHANNEL COMBINATION CONTROL by the UE	5051
8.2.6	<i>Physical channel reconfiguration</i>	5052
8.2.6.1	General	5152
8.2.6.2	Initiation	5152
8.2.6.2.1	Message PHYSICAL CHANNEL RECONFIGURATION contents to set	5152
8.2.6.3	Reception of PHYSICAL CHANNEL RECONFIGURATION by the UE in CELL_DCH state.....	5152
8.2.6.3.1	Message PHYSICAL CHANNEL RECONFIGURATION contents to use in CELL_DCH state	5153
8.2.6.4	Reception of PHYSICAL CHANNEL RECONFIGURATION by the UE in CELL_FACH state.....	5253

8.2.6.4.1	Message PHYSICAL CHANNEL RECONFIGURATION contents to use in CELL_FACH state	5254
8.2.6.4.2	Message PHYSICAL CHANNEL RECONFIGURATION COMPLETE contents to set.....	5354
8.2.6.5	Reception of PHYSICAL CHANNEL RECONFIGURATION COMPLETE by the UTRAN	5354
8.2.6.6	Abnormal case: Unsupported configuration in the UE	5354
8.2.6.6.1	Message PHYSICAL CHANNEL RECONFIGURATION FAILURE contents to set.....	5354
8.2.6.7	Abnormal case: Physical channel failure	5354
8.2.6.7.1	Message PHYSICAL CHANNEL RECONFIGURATION FAILURE contents to set.....	5355
8.2.6.8	Reception of PHYSICAL CHANNEL RECONFIGURATION FAILURE by the UTRAN	5355
8.2.6.9	Abnormal case: T357 timeout in CELL_DCH state	5355
8.2.6.10	Abnormal case: T357 timeout in CELL_FACH state.....	5455
8.2.6.11	Abnormal case: physical channel failure during transition from CELL_DCH to CELL_FACH.....	5455
8.2.7	<i>Physical Shared Channel Allocation [TDD only]</i>	5455
8.2.7.1	General	5455
8.2.7.2	Initiation	5456
8.2.7.2.1	Message PHYSICAL SHARED CHANNEL ALLOCATION contents to set.....	5456
8.2.7.3	Reception of PHYSICAL SHARED CHANNEL ALLOCATION by the UE.....	5556
8.2.7.3.1	Message PHYSICAL SHARED CHANNEL ALLOCATION contents to use	5556
8.2.8	<i>PUSCH capacity request [TDD only]</i>	5557
8.2.8.1	General	5657
8.2.8.2	Initiation	5657
8.2.8.2.1	Message PUSCH CAPACITY REQUEST contents to set.....	5658
8.2.8.3	Reception of PUSCH CAPACITY REQUEST by the UTRAN	5658
8.2.8.3.1	Message PHYSICAL SHARED CHANNEL ALLOCATION contents to set.....	5758
8.2.8.4	Reception of PHYSICAL SHARED CHANNEL ALLOCATION by the UE.....	5758
8.2.8.4.1	Message PHYSICAL SHARED CHANNEL ALLOCATION contents to use	5758
8.2.8.5	Abnormal case: T310 time out.....	5758
8.2.8.6	Abnormal case: Maximum number of re-attempts exceeded	5758
8.2.9	<i>Downlink power control</i>	5759
8.2.9.1	General	5859
8.2.9.2	Initiation	5859
8.2.9.2.1	Message DOWNLINK OUTER LOOP CONTROL contents to set	5859
8.2.9.3	Reception of DOWNLINK OUTER LOOP CONTROL by the UE.....	5859
8.2.9.3.1	Message DOWNLINK OUTER LOOP CONTROL contents to use	5859
8.3	RRC CONNECTION MOBILITY PROCEDURES	5960
8.3.1	<i>Cell update</i>	5960
8.3.1.1	General	5960
8.3.1.2	Initiation	6061
8.3.1.2.1	Cell update due to cell reselection	6061
8.3.1.2.2	Cell update due to periodical cell update.....	6061
8.3.1.2.3	Cell update due to UL data transmission	6061
8.3.1.2.4	Cell update due to paging response.....	6061
8.3.1.3	Abnormal cases: T305 expiry and the UE detects that it is out of service area.....	6061
8.3.1.3.1	Re-entering of service area.....	6162
8.3.1.3.2	Expiry of timer T307.....	6162
8.3.1.3.3	Message CELL UPDATE contents to set	6162
8.3.1.4	Reception of CELL UPDATE by the UTRAN	6162
8.3.1.4.1	Message CELL UPDATE CONFIRM contents to set	6162
8.3.1.5	Reception of CELL UPDATE CONFIRM by the UE	6162
8.3.1.5.1	Message CELL UPDATE CONFIRM contents to use.....	6263
8.3.1.6	Abnormal cases: T302 expiry or cell reselection	6263
8.3.1.7	Reception of RNTI REALLOCATION COMPLETE by the UTRAN	6264
8.3.1.8	Reception of PHYSICAL CHANNEL RECONFIGURATION COMPLETE by the UTRAN	6364
8.3.1.9	Abnormal case: T357 expiry.....	6364
8.3.2	<i>URA update</i>	6364
8.3.2.1	General	6364
8.3.2.2	Initiation	6365
8.3.2.2.1	URA update due to URA reselection	6365
8.3.2.2.2	URA update due to periodical URA update.....	6465
8.3.2.3	Abnormal cases: T306 expiry and the UE detects that it is out of service area.....	6465
8.3.2.4	Message URA UPDATE contents to set	6465
8.3.2.5	Reception of URA UPDATE by the UTRAN.....	6465
8.3.2.5.1	Message URA UPDATE CONFIRM contents to set	6465
8.3.2.6	Reception of URA UPDATE CONFIRM by the UE.....	6466
8.3.2.6.1	Message URA UPDATE CONFIRM contents to use	6466
8.3.2.7	Abnormal cases: Confirmation error of URA ID list	6566
8.3.2.8	Abnormal cases: T303 expiry or URA reselection	6566

8.3.2.9	Reception of RNTI REALLOCATION COMPLETE by the UTRAN	6567
8.3.3	<i>RNTI reallocation</i>	6667
8.3.3.1	Purpose	6667
8.3.3.2	Initiation	6667
8.3.3.3	Reception of RNTI REALLOCATION by the UE	6667
8.3.3.3.1	Message RNTI REALLOCATION contents to use	6667
8.3.3.4	Reception of RNTI REALLOCATION COMPLETE by the UTRAN	6667
8.3.4	<i>Active set update in soft handover</i>	6667
8.3.4.1	Initiation	6768
8.3.4.1.1	Message ACTIVE SET UPDATE contents to set	6768
8.3.4.2	Reception of message ACTIVE SET UPDATE by the UE	6768
8.3.4.2.1	Message ACTIVE SET UPDATE contents to use	6769
8.3.4.2.2	Message ACTIVE SET UPDATE COMPLETE contents to set	6869
8.3.4.3	Abnormal case: Unsupported configuration in the UE	6869
8.3.4.3.1	Message ACTIVE SET UPDATE FAILURE contents to set	6869
8.3.4.4	Reception of message ACTIVE SET UPDATE COMPLETE by the UTRAN	6869
8.3.4.5	Reception of message ACTIVE SET UPDATE FAILURE by the UTRAN	6869
8.3.4.6	Abnormal case: T360 timeout	6869
8.3.5	<i>Hard handover</i>	6869
8.3.5.1	General	6970
8.3.5.2	Initiation	6970
8.3.5.2.1	Message HANDOVER COMMAND contents to set	6970
8.3.5.3	Reception of message HANDOVER COMMAND by the UE	6971
8.3.5.3.1	Message HANDOVER COMMAND contents to use	7071
8.3.5.3.1	Message HANDOVER COMPLETE contents to set	7071
8.3.5.4	Abnormal case: Unsupported configuration in the UE	7071
8.3.5.4.1	Message HANDOVER FAILURE contents to set	7071
8.3.5.5	Abnormal case: Physical channel failure	7071
8.3.5.5.1	Message HANDOVER FAILURE contents to set	7071
8.3.5.6	Reception of message HANDOVER COMPLETE by the UTRAN	7072
8.3.5.7	Reception of message HANDOVER FAILURE by the UTRAN	7172
8.3.5.8	Abnormal case: T358 timeout	7172
8.3.6	<i>Inter-system handover to UTRAN</i>	7172
8.3.6.1	General	7172
8.3.6.2	Initiation	7172
8.3.6.2.1	Message XXXX contents to set	7172
8.3.6.3	Reception of message XXXX by the UE	7173
8.3.6.3.1	Message XXXX contents to use	7273
8.3.6.3.2	Message HANDOVER COMPLETE contents to set	7273
8.3.6.4	Abnormal case: UE fails to perform handover	7273
8.3.6.5	Reception of message HANDOVER COMPLETE by the UTRAN	7273
8.3.6.5.1	Message HANDOVER COMPLETE contents to use	7273
8.3.7	<i>Inter-system handover from UTRAN</i>	7274
8.3.7.1	General	7374
8.3.7.2	Initiation	7374
8.3.7.2.1	Message INTER- SYSTEM HANDOVER COMMAND contents to set	7374
8.3.7.3	Reception of message INTER- SYSTEM HANDOVER COMMAND by the UE	7374
8.3.7.3.1	Message INTER- SYSTEM HANDOVER COMMAND contents to use	7375
8.3.7.4	Successful completion of the inter-system handover	7475
8.3.7.5	Abnormal case: UE fails to complete requested handover	7475
8.3.7.5.1	Message INTER-SYSTEM HANDOVER FAILURE contents to set	7475
8.3.7.6	Reception of INTER-SYSTEM HANDOVER FAILURE by UTRAN	7475
8.3.7.7	Abnormal case: expiry of timer T359 in UTRAN	7475
8.3.8	<i>Inter-system cell reselection to UTRAN</i>	7475
8.3.8.1	General	7475
8.3.8.2	Initiation	7475
8.3.8.2.1	Message RRC CONNECTION REQUEST contents to set	7475
8.3.8.3	Abnormal case: UE fails to complete an inter-system cell reselection	7475
8.3.9	<i>Inter-system cell reselection from UTRAN</i>	7476
8.3.9.1	General	7476
8.3.9.2	Initiation	7576
8.3.9.3	Successful cell reselection	7576
8.3.9.4	Expiry of timer T309	7576
8.4	MEASUREMENT PROCEDURES	7677
8.4.1	<i>Measurement control</i>	7778
8.4.1.1	General	7778

8.4.1.2	Initiation	<u>7778</u>
8.4.1.2.1	Message MEASUREMENT CONTROL contents to set	<u>7879</u>
8.4.1.3	Reception of MEASUREMENT CONTROL by the UE	<u>7879</u>
8.4.1.3.1	Message MEASUREMENT CONTROL contents to use	<u>7879</u>
8.4.1.4	Abnormal case: Unsupported measurement in the UE	<u>7879</u>
8.4.1.4.1	Message MEASUREMENT CONTROL FAILURE contents to set.....	<u>7879</u>
8.4.1.5	Reception of MEASUREMENT CONTROL FAILURE by the UTRAN	<u>7880</u>
8.4.2	<i>Measurement report</i>	<u>7980</u>
8.4.2.1	Purpose	<u>7980</u>
8.4.2.2	Initiation	<u>7980</u>
8.4.2.2.1	Message MEASUREMENT REPORT contents to set.....	<u>7980</u>
8.4.2.3	Reception of MEASUREMENT REPORT by the UTRAN	<u>7980</u>
8.5	GENERAL PROCEDURES	<u>8081</u>
8.5.1	<i>Selection of initial UE identity</i>	<u>8081</u>
8.5.2	<i>Actions when entering idle mode</i>	<u>8081</u>
8.5.3	<i>Actions when entering CELL_DCH state</i>	<u>8081</u>
8.5.4	<i>Physical channel establishment criteria</i>	<u>8081</u>
8.5.5	<i>Detection of out of service area</i>	<u>8081</u>
8.5.6	<i>Radio link failure criteria</i>	<u>8081</u>
8.5.7	<i>Default actions on receipt of an information element</i>	<u>8081</u>
8.5.7.1	CN information elements.....	<u>8081</u>
8.5.7.2	UTRAN mobility information elements	<u>8081</u>
8.5.7.3	UE information elements.....	<u>8081</u>
8.5.7.3.1	Activation time.....	<u>8081</u>
8.5.7.3.6	UTRAN DRX Cycle length	<u>8081</u>
8.5.7.3.7	DRX Indicator	<u>8182</u>
8.5.7.4	Radio bearer information elements	<u>8182</u>
8.5.7.4.1	RB mapping info.....	<u>8182</u>
8.5.7.4.2	RLC Info.....	<u>8182</u>
8.5.7.5	Transport channel information elements.....	<u>8182</u>
8.5.7.5.1	Transport Format Set	<u>8182</u>
8.5.7.5.2	Transport format combination set	<u>8182</u>
8.5.7.5.3	Transport format combination subset.....	<u>8182</u>
8.5.7.6	Physical channel information elements.....	<u>8283</u>
8.5.7.6.1	Frequency info	<u>8283</u>
8.5.7.6.2	PRACH info.....	<u>8283</u>
8.5.7.6.3	Secondary CCPCH info	<u>8283</u>
8.5.7.6.4	Uplink DPCH info	<u>8283</u>
8.5.7.6.5	Downlink DPCH info	<u>8283</u>
8.5.7.6.6	Maximum allowed UL TX power.....	<u>8283</u>
8.5.7.7	Measurement information elements.....	<u>8283</u>
8.5.7.8	Other information elements	<u>8283</u>
9	PROTOCOL STATES	<u>8384</u>
9.1	RRC STATES AND STATE TRANSITIONS INCLUDING GSM.....	<u>8384</u>
9.2	TRANSITION FROM IDLE MODE TO UTRAN CONNECTED MODE	<u>8485</u>
9.3	UTRAN CONNECTED MODE STATES AND TRANSITIONS	<u>8485</u>
9.3.1	<i>CELL_DCH state</i>	<u>8485</u>
9.3.1.3	Transition from CELL_DCH to Idle Mode	<u>8485</u>
9.3.1.4	Transition from CELL_DCH to CELL_FACH state	<u>8485</u>
9.3.1.5	Radio Resource Allocation tasks (CELL_DCH)	<u>8485</u>
9.3.1.6	RRC Connection mobility tasks (CELL_DCH).....	<u>8586</u>
9.3.1.7	Localised Service Area (LSA) support.....	<u>8586</u>
9.3.1.8	UE Measurements (CELL_DCH).....	<u>8586</u>
9.3.1.9	Transfer and update of system information (CELL_DCH).....	<u>8586</u>
9.3.2	<i>CELL_FACH state</i>	<u>8586</u>
9.3.2.1	Transition from CELL_FACH to CELL_DCH state	<u>8687</u>
9.3.2.2	Transition from CELL_FACH to CELL_PCH state	<u>8687</u>
9.3.2.3	Transition from CELL_FACH to Idle Mode	<u>8687</u>
9.3.2.4	Transition from CELL_FACH to URA_PCH State.....	<u>8687</u>
9.3.2.5	Radio Resource Allocation Tasks (CELL_FACH).....	<u>8687</u>
9.3.2.6	RRC Connection mobility tasks (CELL_FACH).....	<u>8788</u>
9.3.2.7	UE Measurements (CELL_FACH).....	<u>8788</u>
9.3.2.8	Transfer and update of system information (CELL_FACH).....	<u>8789</u>
9.3.3	<i>CELL_PCH state</i>	<u>8889</u>

9.3.3.1	Transition from CELL_PCH to URA_PCH State	<u>8889</u>
9.3.3.2	Transition from CELL_PCH to CELL_FACH state	<u>8889</u>
9.3.3.3	Radio Resource Allocation Tasks (CELL_PCH)	<u>8889</u>
9.3.3.4	RRC Connection mobility tasks (CELL_PCH)	<u>8890</u>
9.3.3.5	UE Measurements (CELL_PCH)	<u>8990</u>
9.3.3.6	Transfer and update of system information (CELL_PCH)	<u>8990</u>
9.3.4	<i>URA_PCH State</i>	<u>8990</u>
9.3.4.1	Transition from URA_PCH State to Cell_FACH State	<u>8990</u>
9.3.4.2	Radio Resource Allocation Tasks (URA_PCH)	<u>8991</u>
9.3.4.3	RRC Connection mobility tasks (URA_PCH)	<u>8991</u>
9.3.4.4	UE Measurements	<u>9091</u>
9.3.4.5	Transfer and update of system information (URA_PCH)	<u>9091</u>
9.4	INTER-SYSTEM HANDOVER WITH PSTN/ISDN DOMAIN SERVICES	<u>9091</u>
9.5	INTER-SYSTEM HANDOVER WITH IP DOMAIN SERVICES	<u>9091</u>
9.6	INTER-SYSTEM HANDOVER WITH SIMULTANEOUS IP AND PSTN/ISDN DOMAIN SERVICES	<u>9091</u>
9.6.1	<i>Inter-system handover UTRAN to GSM / BSS</i>	<u>9092</u>
9.6.2	<i>Inter-system handover GSM / BSS to UTRAN</i>	<u>9192</u>
10	MESSAGE AND INFORMATION ELEMENT FUNCTIONAL DEFINITION AND CONTENT	<u>9293</u>
10.1	RADIO RESOURCE CONTROL MESSAGES	<u>9293</u>
10.1.1	<i>RRC Connection Mobility Messages</i>	<u>9293</u>
10.1.1.1	ACTIVE SET UPDATE (FDD only)	<u>9293</u>
10.1.1.2	ACTIVE SET UPDATE COMPLETE (FDD only)	<u>9394</u>
10.1.1.3	ACTIVE SET UPDATE FAILURE (FDD only)	<u>9394</u>
10.1.1.4	CELL UPDATE	<u>9495</u>
10.1.1.5	CELL UPDATE CONFIRM (FDD only)	<u>9495</u>
10.1.1.6	HANDOVER COMMAND	<u>9697</u>
10.1.1.7	HANDOVER COMPLETE	<u>9798</u>
10.1.1.8	HANDOVER FAILURE	<u>9798</u>
10.1.1.9	INTER-SYSTEM HANDOVER COMMAND	<u>9798</u>
10.1.1.10	INTER-SYSTEM HANDOVER FAILURE	<u>9899</u>
10.1.1.11	URA UPDATE	<u>9899</u>
10.1.1.12	URA UPDATE CONFIRM	<u>9899</u>
10.1.1.13	RNTI REALLOCATION	<u>99100</u>
10.1.1.14	RNTI REALLOCATION COMPLETE	<u>100101</u>
10.1.2	<i>Measurement Messages</i>	<u>100101</u>
10.1.2.1	MEASUREMENT CONTROL	<u>100101</u>
10.1.2.2	MEASUREMENT CONTROL FAILURE	<u>102104</u>
10.1.2.3	MEASUREMENT REPORT	<u>102104</u>
10.1.3	<i>Paging Messages</i>	<u>103106</u>
10.1.3.1	PAGING TYPE 1	<u>104106</u>
10.1.3.2	PAGING TYPE 2	<u>104106</u>
10.1.4	<i>RRC Connection Establishment and maintenance messages</i>	<u>104106</u>
10.1.4.1	RRC CONNECTION RE-ESTABLISHMENT	<u>104106</u>
10.1.4.2	RRC CONNECTION RE-ESTABLISHMENT COMPLETE	<u>107110</u>
10.1.4.3	RRC CONNECTION RE-ESTABLISHMENT REQUEST	<u>108110</u>
10.1.4.4	RRC CONNECTION RELEASE	<u>108110</u>
10.1.4.5	RRC CONNECTION RELEASE COMPLETE	<u>108111</u>
10.1.4.6	RRC CONNECTION REQUEST	<u>109111</u>
10.1.4.7	RRC CONNECTION SETUP	<u>109111</u>
10.1.4.8	RRC CONNECTION SETUP COMPLETE	<u>111113</u>
10.1.4.9	RRC CONNECTION REJECT	<u>111114</u>
10.1.5	<i>Radio Bearer control messages</i>	<u>112114</u>
10.1.5.1	PHYSICAL CHANNEL RECONFIGURATION	<u>112114</u>
10.1.5.2	PHYSICAL CHANNEL RECONFIGURATION COMPLETE	<u>114116</u>
10.1.5.3	PHYSICAL CHANNEL RECONFIGURATION FAILURE	<u>114116</u>
10.1.5.4	RADIO BEARER RECONFIGURATION	<u>114116</u>
10.1.5.5	RADIO BEARER RECONFIGURATION COMPLETE	<u>116119</u>
10.1.5.6	RADIO BEARER RECONFIGURATION FAILURE	<u>117119</u>
10.1.5.7	RADIO BEARER RELEASE	<u>117119</u>
10.1.5.8	RADIO BEARER RELEASE COMPLETE	<u>119121</u>
10.1.5.9	RADIO BEARER RELEASE FAILURE	<u>120122</u>
10.1.5.10	RADIO BEARER SETUP	<u>120122</u>
10.1.5.11	RADIO BEARER SETUP COMPLETE	<u>123125</u>
10.1.5.12	RADIO BEARER SETUP FAILURE	<u>123125</u>
10.1.5.13	TRANSPORT CHANNEL RECONFIGURATION	<u>123125</u>

10.1.5.14	TRANSPORT CHANNEL RECONFIGURATION COMPLETE.....	125127
10.1.5.15	TRANSPORT CHANNEL RECONFIGURATION FAILURE.....	126128
10.1.5.16	TRANSPORT FORMAT COMBINATION CONTROL.....	126128
10.1.5.17	DOWNLINK OUTER LOOP CONTROL.....	126128
10.1.5.18	PHYSICAL SHARED CHANNEL ALLOCATION (TDD only).....	126129
10.1.5.19	PUSCH CAPACITY REQUEST (TDD only).....	127129
10.1.6	<i>System Information Messages</i>	127130
10.1.6.1	SYSTEM INFORMATION.....	127130
10.1.6.2	First SIB Segment.....	128130
10.1.6.3	Subsequent SIB Segment.....	128130
10.1.6.4	Last SIB Segment.....	129131
10.1.6.4	Complete SIB.....	129131
10.1.6.4	System Information Blocks.....	129131
10.1.6.4.1	SIB Content.....	129131
10.1.6.4.2	Master Information Block.....	130132
10.1.6.4.3	System Information Block type 1.....	131133
10.1.6.4.4	System Information Block type 2.....	131133
10.1.6.4.5	System Information Block type 3.....	132134
10.1.6.4.6	System Information Block type 4.....	132134
10.1.6.4.7	System Information Block type 5.....	133135
10.1.6.4.8	System Information Block type 6.....	135137
10.1.6.4.9	System Information Block type 7.....	136138
10.1.6.4.10	System Information Block type 8.....	136138
10.1.6.4.11	System Information Block type 9 (FDD).....	137139
10.1.6.4.11	System Information Block type 10 (FDD).....	137139
10.1.6.4.12	System Information Block type 11.....	138140
10.1.6.4.14	System Information Block type 12.....	139141
10.1.7	<i>Other Messages</i>	141143
10.1.7.1	UE CAPABILITY INFORMATION.....	141143
10.1.7.2	UE CAPABILITY INFORMATION CONFIRM.....	141143
10.1.7.3	UE CAPABILITY ENQUIRY.....	142144
10.1.7.4	DIRECT TRANSFER.....	142144
10.1.7.5	SECURITY MODE CONTROL COMMAND.....	142144
10.1.7.6	SECURITY MODE CONTROL COMPLETE.....	143145
10.2	INFORMATION ELEMENT FUNCTIONAL DEFINITIONS.....	144146
10.2.1	<i>CN Information elements</i>	144146
10.2.1.1	CN domain identity.....	144146
10.2.1.2	NAS binding info.....	144146
10.2.1.3	NAS message.....	144146
10.2.1.4	NAS system information.....	144146
10.2.1.5	PLMN identity.....	144146
10.2.1.6	CN DRX cycle length.....	144146
10.2.1.7	CN Type.....	144146
10.2.2	<i>UTRAN mobility Information elements</i>	144146
10.2.2.1	Cell identity.....	144146
10.2.2.2	Cell selection and re-selection info.....	145147
10.2.2.3	Information for periodic cell and URA update.....	145147
10.2.2.4	URA identity.....	145147
10.2.3	<i>UE Information elements</i>	146148
10.2.3.1	Uplink access control info.....	146148
10.2.3.2	C-RNTI.....	146148
10.2.3.3	U-RNTI.....	147149
10.2.3.4	Initial UE identity.....	147149
10.2.3.5	Activation time.....	147149
10.2.3.6	Wait time.....	147149
10.2.3.7	Paging record.....	148150
10.2.3.8	Establishment cause.....	148150
10.2.3.9	Release cause.....	149151
10.2.3.10	Rejection cause.....	149151
10.2.3.11	Paging cause.....	149151
10.2.3.12	Initial UE capability.....	149151
10.2.3.13	Power control capability.....	149152
10.2.3.14	Code resource capability.....	149152
10.2.3.15	UE mode capability.....	150152
10.2.3.16	Transport channel support capability.....	150152
10.2.3.17	Ciphering capability.....	150153

10.2.3.18 Macro diversity capability.....	150153
10.2.3.19 Cell update cause	150153
10.2.3.20 URA update cause.....	151153
10.2.3.21 Number of RRC Message Transmissions.....	151153
10.2.3.22 Inter-system handover failure cause	151153
10.2.3.23 Transmission probability.....	151153
10.2.3.24 Maximum bit rate.....	151153
10.2.3.25 Capability Update Requirement	151154
10.2.3.26 CPCH Parameters.....	151154
10.2.3.27 UE Timers and Counters	152154
10.2.3.28 AM_RLC error indication.....	152155
10.2.3.29 RLC re-configuration indicator.....	152155
10.2.3.30 Failure cause	153155
10.2.3.31 UTRAN DRX cycle length	153155
10.2.3.32 DRX Indicator.....	153155
10.2.4 Radio Bearer Information elements.....	153155
10.2.4.1 RB identity.....	153155
10.2.4.2 RLC info	154156
10.2.4.2.1 Transmission RLC Discard.....	155157
10.2.4.2.2 Polling info	156158
10.2.4.2.3 Downlink RLC STATUS info	156158
10.2.4.3 Signalling link type	156158
10.2.4.4 RB mapping info.....	156158
10.2.5 Transport CH Information elements.....	157159
10.2.5.1 Transport Format Combination Set.....	157159
10.2.5.2 Transport Format Combination Subset	158160
10.2.5.3 Transport channel identity.....	158160
10.2.5.4 Transport Format Set (TFS).....	159161
10.2.5.5 Dynamic Control.....	159161
10.2.5.6 Transmission time validity	159161
10.2.5.7 Time duration before retry	160162
10.2.5.8 Silent period duration before release.....	160162
10.2.5.9 Transport Format Combination Set Identity.....	160162
10.2.5.10 Transparent mode signalling info.....	160162
10.2.6 Physical CH Information elements	160163
10.2.6.1 Frequency info	160163
10.2.6.2 Primary CPICH info (FDD only).....	161163
10.2.6.3 Secondary CPICH info (FDD only).....	161163
10.2.6.4 Primary CCPCH info	161164
10.2.6.5 Secondary CCPCH info	162164
10.2.6.6 PRACH info (for RACH).....	163165
10.2.6.8 Uplink DPCH info	165167
10.2.6.9 Uplink DPCH power control info	166168
10.2.6.10 Downlink DPCH info.....	167169
10.2.6.11 FB Mode Transmit Diversity signalling indicator.....	168170
10.2.6.12 SSSDT indicator (FDD only).....	168170
10.2.6.13 SSSDT cell identity (FDD only)	168170
10.2.6.14 Gated Transmission Control info (FFS) (FDD only)	169171
10.2.6.15 Default DPCH Offset Value (FDD only)	169171
10.2.6.16 RF channel number priority	169171
10.2.6.17 AICH Info (FDD only).....	169171
10.2.6.18 PICH Info.....	169171
10.2.6.19 PRACH info (for FAUSCH) (FDD only).....	170172
10.2.6.20 CPCH set info (FDD only).....	170172
10.2.6.21 CPCH persistency values (FDD only).....	171173
10.2.6.22 Downlink DPCH compressed mode info (FDD only).....	171173
10.2.6.23 Downlink DPCH power control information	172174
10.2.6.24 Downlink Outer Loop Control	172174
10.2.6.25 Timing Advance (TDD only)	173175
10.2.6.26 PSCH Timeslot (TDD only).....	173175
10.2.6.27 ASC Info (TDD only).....	173175
10.2.6.28 PUSCH info (TDD only).....	173175
10.2.6.29 PDSCH info (TDD only).....	173176
10.2.6.30 PUSCH power control info (TDD only)	174176
10.2.6.31 Maximum allowed UL TX power	174176
10.2.7 Measurement Information elements.....	174177
10.2.7.1 Measurement Identity Number.....	174177

10.2.7.2 Measurement Command.....	174177
10.2.7.3 Measurement Type.....	175177
10.2.7.4 Reference time difference to cell.....	175177
10.2.7.5 Measured time difference to UTRA cell.....	175177
10.2.7.6 Measured time difference to GSM cell.....	175177
10.2.7.7 Measurement reporting mode.....	175177
10.2.7.8 Intra-frequency cell info.....	176178
10.2.7.9 Inter-frequency cell info.....	176178
10.2.7.10 Inter-system cell info.....	176178
10.2.7.11 Traffic volume measurement object.....	176179
10.2.7.12 Quality measurement object (FFS).....	176179
10.2.7.13 Intra-frequency measurement quantity.....	177179
10.2.7.14 Inter-frequency measurement quantity (FFS).....	177179
10.2.7.15 Inter-system measurement quantity (FFS).....	177179
10.2.7.16 Traffic volume measurement quantity.....	177180
10.2.7.17 UE internal measurement quantity.....	178180
10.2.7.18 Quality measurement quantity (FFS).....	178180
10.2.7.19 Intra-frequency reporting quantity.....	178180
10.2.7.20 Intra-frequency reporting quantity for RACH reporting.....	178181
10.2.7.21 Inter-frequency reporting quantity (FFS).....	179181
10.2.7.22 Inter-system reporting quantity (FFS).....	179182
10.2.7.23 Traffic volume reporting quantity.....	179182
10.2.7.24 Quality reporting quantity (FFS).....	180182
10.2.7.25 Intra-frequency measurement reporting criteria.....	180182
10.2.7.26 Inter-frequency measurement reporting criteria (FFS).....	182185
10.2.7.27 Inter-system measurement reporting criteria (FFS).....	182185
10.2.7.28 Traffic volume measurement reporting criteria.....	182185
10.2.7.29 Quality measurement reporting criteria (FFS).....	183186
10.2.7.30 UE internal measurement reporting criteria.....	183186
10.2.7.31 Periodical reporting criteria.....	184187
10.2.7.32 Intra-frequency measurement event results.....	184187
10.2.7.33 Inter-frequency measurement event results (FFS).....	185188
10.2.7.34 Inter-system measurement event results (FFS).....	185188
10.2.7.35 Traffic volume measurement event results.....	185188
10.2.7.36 Quality measurement event results (FFS).....	185188
10.2.7.37 Measured results.....	185188
10.2.7.38 SFN Measurement Indicator.....	186189
10.2.7.39 Maximum number of reported cells on RACH.....	187190
10.2.7.40 Inter-frequency SET UPDATE (FDD only).....	187190
10.2.8 Other Information elements.....	187190
10.2.8.1 BCCH modification info.....	187190
10.2.8.2 Inter-system message.....	188191
10.2.8.3 Segment index.....	188191
10.2.8.4 SIB data.....	188191
10.2.8.5 SI Padding.....	188191
10.2.8.6 SIB type.....	188192
10.2.8.7 Value tag.....	189192
10.2.8.8 Expiration time.....	189192
10.2.8.9 Scheduling information.....	189193
10.2.8.10 SEG COUNT.....	190193
11 MESSAGE AND INFORMATION ELEMENT ABSTRACT SYNTAX (WITH ASN.1).....	190193
12 MESSAGE TRANSFER SYNTAX.....	191195
13 PROTOCOL TIMERS, COUNTERS AND OTHER PARAMETERS.....	191195
13.1 TIMERS FOR UE.....	191195
13.2 TIMERS FOR UTRAN.....	192196
13.3 COUNTERS FOR UE.....	194198
13.4 COUNTERS FOR UTRAN.....	195199
13.5 UE CONSTANTS AND PARAMETERS.....	195199
13.6 UTRAN CONSTANTS AND PARAMETERS.....	195199
14 SPECIFIC FUNCTIONS.....	195199
14.1 INTRA-FREQUENCY MEASUREMENTS.....	195200

14.1.1	<i>Intra-frequency measurement quantities</i>	195200
14.1.2	<i>Intra-frequency reporting events for FDD</i>	196200
14.1.2.1	Reporting event 1A: A Primary CPICH enters the reporting range	196200
14.1.2.2	Reporting event 1B: A primary CPICH leaves the reporting range.....	197201
14.1.2.3	Reporting event 1C: A non-active primary CPICH becomes better than an active primary CPICH	197201
14.1.2.4	Reporting event 1D: Change of best cell.....	198202
14.1.2.5	Reporting event 1E: A Primary CPICH becomes better than an absolute threshold	198202
14.1.2.6	Reporting event 1F: A Primary CPICH becomes worse than an absolute threshold.....	199204
14.1.3	<i>Intra-frequency reporting events for TDD</i>	199204
14.1.3.1	Change of best cell	199204
14.1.3.2	DL CCTrCH below a certain threshold.....	200205
14.1.3.3	DL Timeslot ISCP below a certain threshold	200205
14.1.3.4	DL Timeslot ISCP above a certain threshold	200205
14.1.4	<i>Event-triggered periodic intra-frequency measurement reports</i>	201206
14.1.4.1	Cell addition failure (FDD only).....	201206
14.1.4.2	Cell replacement failure (FDD only).....	202207
14.1.4.3	Timeslot replacement failure (TDD only)	202207
14.1.5	<i>Mechanisms available for modifying intra-frequency measurement reporting behaviour</i>	203208
14.1.5.1	Hysteresis	203208
14.1.5.2	Time-to-trigger	204209
14.1.5.3	Cell individual offsets	205210
14.1.5.4	Forbid a Primary CPICH to affect the reporting range (FDD only)	206211
14.1.6	<i>Report quantities</i>	207212
14.2	TRAFFIC VOLUME MEASUREMENTS	207212
14.2.1	<i>Traffic Volume Measurement Quantity</i>	207212
14.2.2	<i>Traffic Volume reporting events</i>	208213
14.2.3	<i>Traffic volume reporting mechanisms</i>	208213
14.2.4	<i>Interruption of user data transmission</i>	209214
14.3	UE INTERNAL MEASUREMENTS.....	209214
14.3.1	<i>UE internal measurement quantities</i>	209214
14.3.2	<i>UE internal measurement reporting events</i>	209214
14.3.2.1	Reporting event 6A: The UE Tx power becomes larger than an absolute threshold	210215
14.3.2.2	Reporting event 6B: The UE Tx power becomes less than an absolute threshold.....	210215
14.3.2.3	Reporting event 6C: The UE Tx power reaches its minimum value.....	210215
14.3.2.4	Reporting event 6D: The UE Tx power reaches its maximum value.....	211216
14.3.2.5	Reporting event 6E: The UE RSSI reaches the UE's dynamic receiver range.....	211216
14.4	DYNAMIC RESOURCE ALLOCATION CONTROL OF UPLINK DCH (FDD ONLY)	211216
14.5	DOWNLINK OUTER LOOP POWER CONTROL.....	212217
14.6	CALCULATED TRANSPORT FORMAT COMBINATION	212217
14.7	PROVISION AND RECEPTION OF RRC INITIALISATION INFORMATION BETWEEN RNCs	212217
14.7.1	<i>RRC Initialisation Information</i>	212218
15	PRIMITIVES BETWEEN RRC AND UPPER LAYERS	216221
16	HANDLING OF UNKNOWN, UNFORESEEN AND ERRONEOUS PROTOCOL DATA	216221
17	SDL	216221
18	APPENDICES: EXAMPLES OF OPERATION	216221
19	HISTORY	217222

Intellectual Property Rights

[Editor's note: This paragraph has been modified from corresponding ETSI text in anticipation of a new version regarding 3GPP.]

IPRs essential or potentially essential to the present deliverable may have been declared to 3GPP. The information pertaining to these essential IPRs, if any, is publicly available for **3GPP members and non-members, free of charge**. This can be found in the latest version of the 3GPP Technical Report: ETR 314: "Intellectual Property Rights (IPRs); Essential or potentially Essential, IPRs notified to 3GPP in respect of 3GPP standards". The most recent update of ETR 314, is available on the 3GPP web server or on request from the Secretariat.

Pursuant to the 3GPP Interim IPR Policy, no investigation, including IPR searches, has been carried out by 3GPP. No guarantee can be given as to the existence of other IPRs not referenced in the ETR 314, which are, or may be, or may become, essential to the present document.

Foreword

This Technical Specification has been produced by the 3GPP.

The contents of the present document are subject to continuing work within the TSG and may change following formal TSG approval. Should the TSG modify the contents of this TS, it will be re-released by the TSG with an identifying change of release date and an increase in version number as follows:

Version 3.y.z

where:

- x the first digit:
 - 1 presented to TSG for information;
 - 2 presented to TSG for approval;
 - 3 Indicates TSG approved document under change control.
- y the second digit is incremented for all changes of substance, i.e. technical enhancements, corrections, updates, etc.
- z the third digit is incremented when editorial only changes have been incorporated in the specification.

1. Scope

The scope of this specification is to describe the Radio Resource Control protocol for the 3GPP radio system.

2. References

- [1] UMTS 25.XX, 'Vocabulary for the UTRAN'
 - [2] 25.301, 'Radio Interface Protocol Architecture'
 - [3] 25.303, 'Description of UE states and procedures in connected mode'
-

3. Definitions, Symbols and abbreviations

3.1 Definitions

See [1] for definition of fundamental concepts and vocabulary

3.2 Abbreviations

ACK	Acknowledgement
AICH	Acquisition Indicator CHannel
AM	Acknowledged Mode
AS	Access Stratum
ASN.1	Abstract Syntax Notation.1
BCCH	Broadcast Control Channel
BCFE	Broadcast Control Functional Entity
BER	Bit Error Rate
BLER	Block Error Rate
BSS	Base Station Sub-system
C	Conditional
CCPCH	Common Control Physical CHannel
CCCH	Common Control Channel
CN	Core Network
CM	Connection Management
CPCH	Common Packet CHannel
C-RNTI	CRNC RNTI
DCA	Dynamic Channel Allocation
DCCH	Dedicated Control Channel
DCFE	Dedicated Control Functional Entity
DCH	Dedicated Channel
DC-SAP	Dedicated Control SAP
DL	Downlink
DRAC	Dynamic Resource Allocation Control
DSCH	Downlink Shared Channel
DTCH	Dedicated Traffic Channel
FACH	Forward Access Channel
FAUSCH	Fast Uplink Signalling Channel
FDD	Frequency Division Duplex
FFS	For Further Study

GC-SAP	General Control SAP
ID	Identifier
IMEI	International Mobile Equipment Identity
IMSI	International Mobile Subscriber Identity
IP	Internet Protocol
ISCP	Interference on Signal Code Power
LAI	Location Area Identity
L1	Layer 1
L2	Layer 2
L3	Layer 3
M	Mandatory
MAC	Media Access Control
MCC	Mobile Country Code
MM	Mobility Management
MNC	Mobile Network Code
MS	Mobile Station
NAS	Non Access Stratum
Nt-SAP	Notification SAP
NW	Network
O	Optional
ODMA	Opportunity Driven Multiple Access
PCCH	Paging Control Channel
PCH	Paging Channel
PDSCH	Physical Downlink Shared Channel
PDU	Protocol Data Unit
PLMN	Public Land Mobile Network
PNFE	Paging and Notification Control Functional Entity
PRACH	Physical Random Access CHannel
P-TMSI	Packet Temporary Mobile Subscriber Identity
PUSCH	Physical Uplink Shared Channel
QoS	Quality of Service
RAB	Radio access bearer
RAI	Routing Area Identity
RACH	Random Access CHannel
RB	Radio Bearer
RFE	Routing Functional Entity
RL	Radio Link
RLC	Radio Link Control
RNTI	Radio Network Temporary Identifier
RNC	Radio Network Controller
RRC	Radio Resource Control
RSCP	Received Signal Code Power
RSSI	Received Signal Strength Indicator
SAP	Service Access Point
SCFE	Shared Control Function Entity
SF	Spreading Factor
SHCCH	Shared Control Channel
SIR	Signal to Interference Ratio
SSDT	Site Selection Diversity Transmission
S-RNTI	SRNC - RNTI
tbd	to be decided
TDD	Time Division Duplex
TF	Transport Format
TFCS	Transport Format Combination Set
TFS	Transport Format Set
TME	Transfer Mode Entity
TMSI	Temporary Mobile Subscriber Identity
Tr	Transparent
Tx	Transmission
UE	User Equipment

UL	Uplink
UM	Unacknowledged Mode
UMTS	Universal Mobile Telecommunications System
UNACK	Unacknowledgement
URA	UTRAN Registration Area
USCH	Uplink Shared Channel
UTRAN	UMTS Terrestrial Radio Access Network

4. General

The functional entities of the RRC layer are described below:

- Routing of higher layer messages to different MM/CM entities (UE side) or different core network domains (UTRAN side) is handled by the Routing Function Entity (**RFE**)
- Broadcast functions are handled in the broadcast control function entity (**BCFE**). The BCFE is used to deliver the RRC services which are required at the GC-SAP. The BCFE can use the lower layer services provided by the Tr-SAP and UM-SAP.
- Paging of idle mode UE(s) is controlled by the paging and notification control function entity (**PNFE**). The PNFE is used to deliver the RRC services which are required at the Nt-SAP. The PNFE can use the lower layer services provided by the Tr-SAP and UM-SAP.
- The Dedicated Control Function Entity (**DCFE**) handles all functions specific to one UE. The DCFE is used to deliver the RRC services which are required at the DC-SAP and can use lower layer services of UM/AM-SAP and Tr-SAP depending on the message to be sent and on the current UE service state.
- In TDD mode, the DCFE is assisted by the Shared Control Function Entity (SCFE) location in the C-RNC, which controls the allocation of the PDSCH and PUSCH using lower layers services of UM-SAP and Tr-SAP.
- The Transfer Mode Entity (TME) handles the mapping between the different entities inside the RRC layer and the SAP's provided by RLC.

Logical information exchange is necessary also between the RRC sublayer functional entities. Most of that is implementation dependent and not necessary to present in detail in a specification.

[Figure 1](#) shows the RRC model for the UE side and [Figure 3](#) shows the RRC model for the UTRAN side.

[Editors note: Some further clarification in the diagrams may be beneficial to acknowledge the fact that a DC-SAP for example might be offered over a dedicated channel (with RRC terminated in SRNC) whereas GC-SAP and Nt-SAP may be offered over BCCH, PCH respectively in which cases RRC is located in Node B. It could be concluded from the figure that these channels use the same SAP offered by RLC (Tr-SAP, UM-SAP, AM-SAP) whereas in fact they will use different SAP's, though the SAP type might be the same]

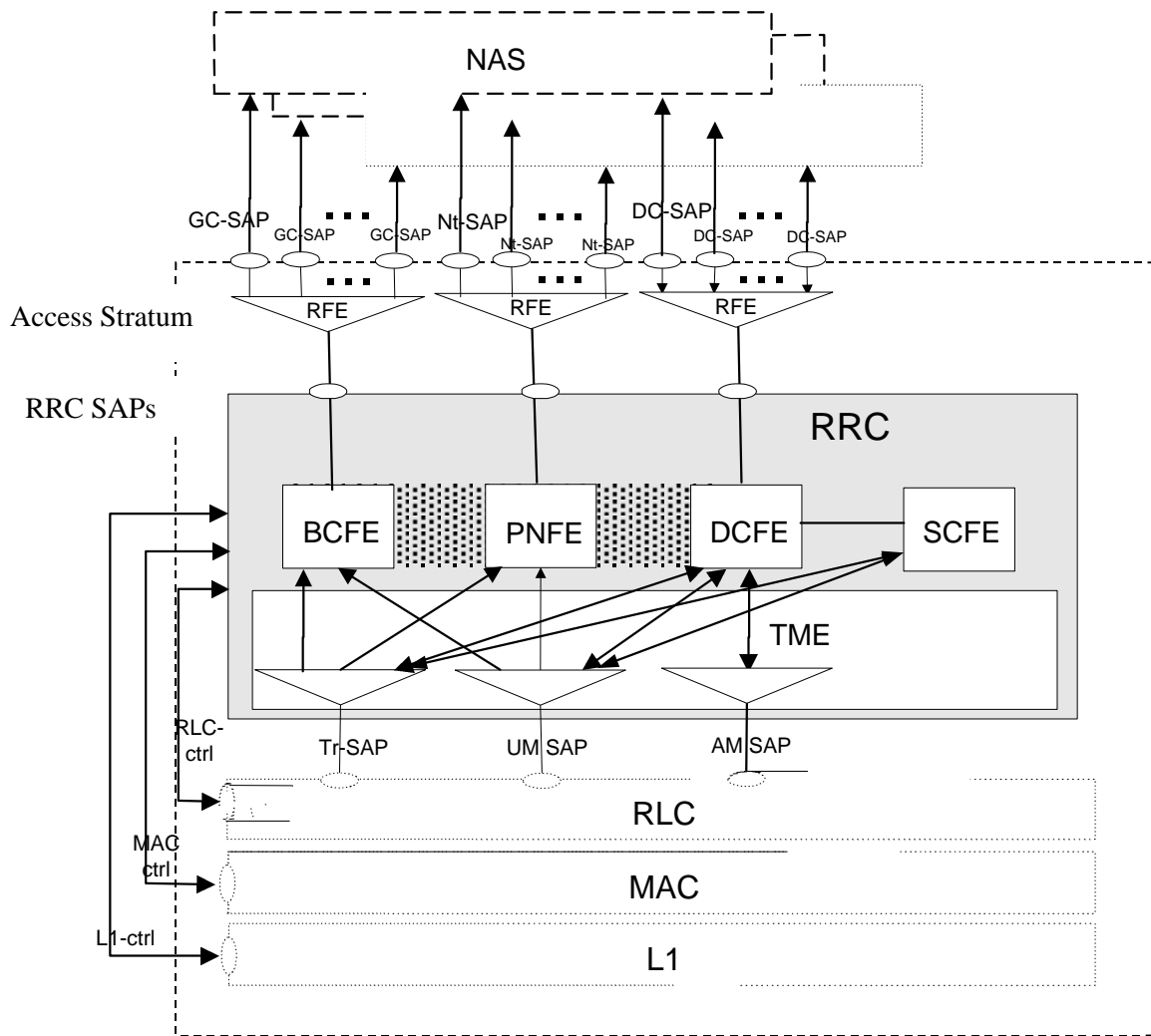

Figure 1) UE side model of RRC

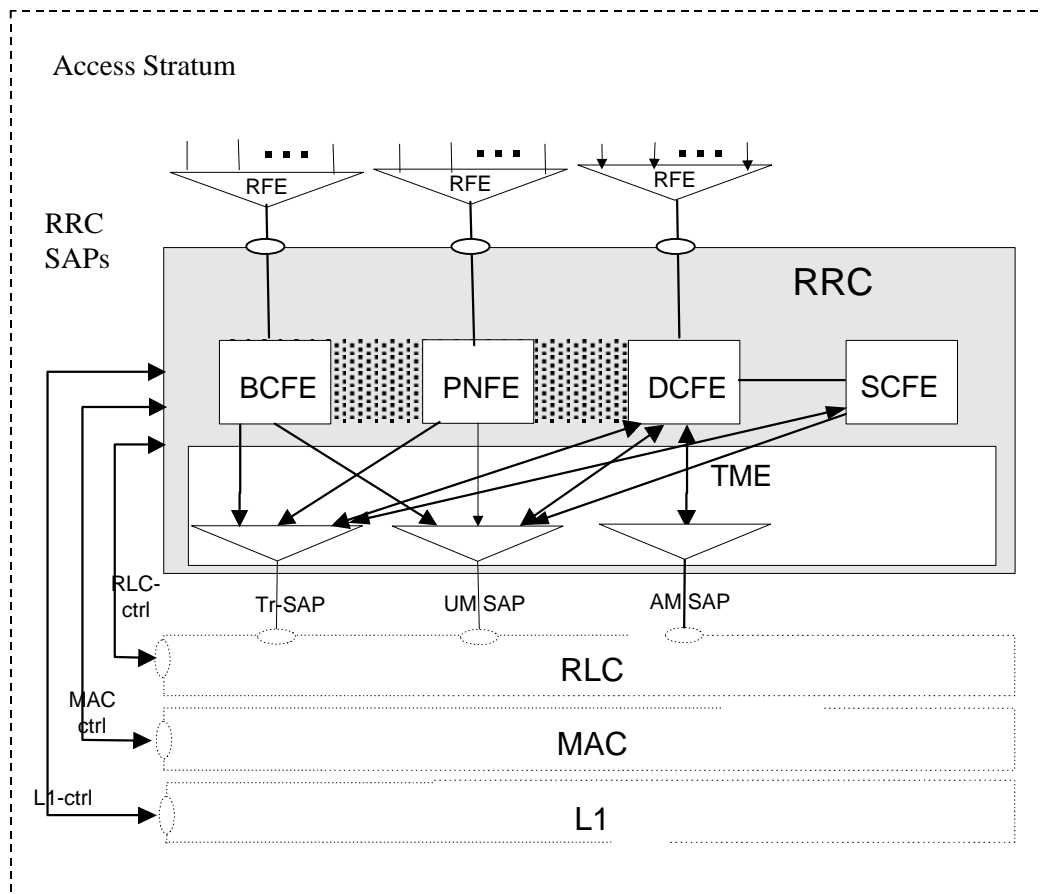

Figure 32) UTRAN side RRC model

5 RRC Services provided to upper layers

The RRC offers the following services to upper layers, a description of these services is provided in [2].

- **General Control**
- **Notification**
- **Dedicated control**

6 Services expected from lower layers

6.1 Services expected from Layer 2

6.2 Services expected from Layer 1

7 Functions of RRC

The RRC performs the functions listed below, a more detailed description of these functions is provided in 25.301:

- **Broadcast of information provided by the non-access stratum (Core Network).**
- **Broadcast of information related to the access stratum.**
- **Establishment, maintenance and release of an RRC connection between the UE and UTRAN**
- **Establishment, reconfiguration and release of Radio Bearers**
- **Assignment, reconfiguration and release of radio resources for the RRC connection**
- **RRC connection mobility functions**
- **Routing of higher layer PDU's**
- **Control of requested QoS.**
- **UE measurement reporting and control of the reporting.**
- **Outer loop power control.**
- **Control of ciphering.**
- **Slow DCA.**
- **Broadcast of ODMA relay node neighbour information**
- **Collation of ODMA relay nodes neighbour lists and gradient information**
- **Maintenance of number of ODMA relay node neighbours**
- **Establishment, maintenance and release of a route between ODMA relay nodes**
- **Interworking between the Gateway ODMA relay node and the UTRAN**
- **Contention resolution (TDD mode)**
- **Paging/notification.**
- **Initial cell selection and re-selection in idle mode.**
- **Arbitration of radio resources on uplink DCH**
- **RRC message integrity protection**
- **Timing advance (TDD mode)**

The following functions are regarded as further study items:

- **Congestion control.**
- **Arbitration of the radio resource allocation between the cells.**

8 RRC procedures

8.1 RRC Connection Management Procedures

8.1.1 Broadcast of system information

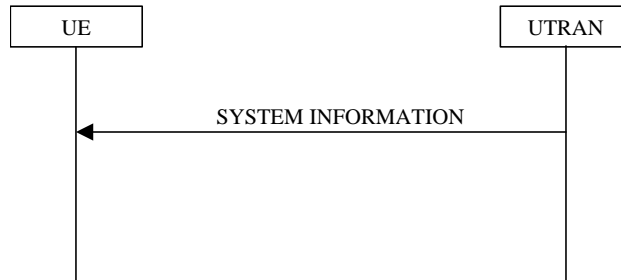

Figure 53. Broadcast of system information

8.1.1.1 General

The purpose of this procedure is to broadcast system information from the network to idle mode- and connected mode UEs in a cell.

8.1.1.1.1 System information structure

The system information elements are broadcast in *system information blocks*. A system information block groups together system information elements of the same nature. Different system information blocks may have different characteristics, e.g. regarding their repetition rate and the requirements on UEs to re-read the system information blocks.

The system information is organised as a tree. A *master information block* gives references to a number of system information blocks in a cell, including scheduling information for those system information blocks. The system information blocks contain the actual system information and/or references to other system information blocks including scheduling information for those system information blocks.

[Figure 6](#)~~Figure 4~~ illustrates the relationship between the master information block and the system information blocks in a cell.

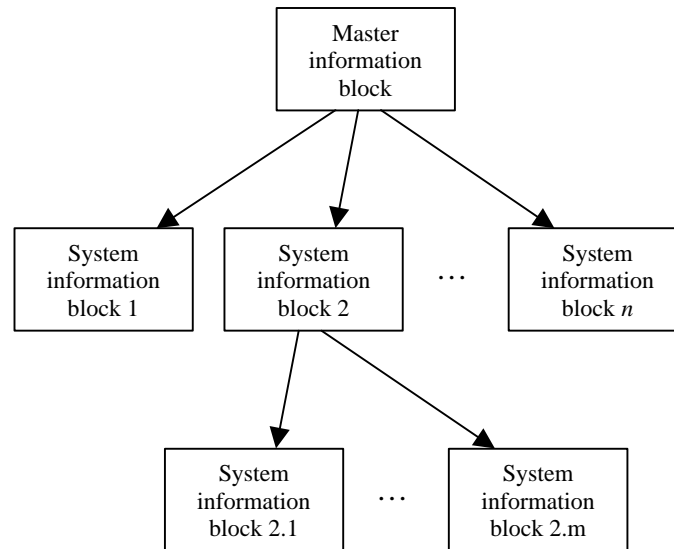

Figure 64. The overall structure of system information.

8.1.1.1.2 Acquisition of system information blocks

[The specification and usage of different system information blocks is FFS]

8.1.1.1.3 Scheduling of system information

All system information blocks are broadcast on the BCCH using transparent mode. A given BCCH may be mapped onto either a BCH transport channel or a FACH transport channel.

The RRC layer in UTRAN shall perform segmentation of system information blocks. The segments shall fit the size of a transport block. When there is space left in a transport block, concatenation of segments belonging to two different system information blocks into the same transport block may be performed. The RRC layer in the UE shall perform re-assembly of segments.

To allow the mixing of system information blocks with short repetition period and system information blocks with segmentation over many frames, UTRAN may multiplex segments from different system information blocks. Multiplexing and de-multiplexing shall be performed by the RRC layer.

UTRAN shall define the following parameters for each system information block broadcast on a BCH transport channel:

- the number of segments (SEG_COUNT).
- the repetition period (SIB_REP). The same value applies to all segments.
- the position (phase) within the repetition period (SIB_POS(0))
- Offset of the subsequent segments in ascending index order (SIB_OFF(i), i=1, 2, ..SEG_COUNT-1)
The position of the subsequent segments are calculated as: $SIB_POS(i) = SIB_POS(i-1) + SIB_OFF(i)$.

The scheduling is based on the Cell System Frame number (SFN). The frame at which a particular segment (i) of a system information block occurs is defined as follows:

$$SFN \bmod SIB_REP = SIB_POS(i)$$

[Note that SIB_POS must be less than SIB_REP for all segments.]

The master information block is scheduled with a fixed pre-defined repetition rate and a fixed pre-defined position. The length of the master information block shall not exceed the size of a transport block.

8.1.1.2 Initiation

The UTRAN shall repeat the system information on a regular basis using the repetition period defined for each system

information block.

8.1.1.3 Reception of SYSTEM INFORMATION by the UE

The UE shall be able to receive SYSTEM INFORMATION broadcast on a BCH transport channel in idle mode as well as in states CELL_FACH, CELL_PCH and URA_PCH. Further, the UE shall be able to receive SYSTEM INFORMATION broadcast on a FACH transport channel in state CELL_FACH. In addition, UEs with certain service capabilities shall be able to receive system information a FACH transport channel in state CELL_DCH. Idle mode- and connected mode UEs may acquire different combinations of system information blocks. Before each acquisition, the UE should identify which system information blocks that are needed.

8.1.1.3.1 Reception of SYSTEM INFORMATION broadcast on a BCH transport channel

The UE may use the pre-defined scheduling information to locate the master information block in the cell.

At reception of the master information block, the UE shall

- check the IE PLMN identity in the master information block, If the PLMN identity is different from the stored PLMN identity, the UE shall store that PLMN identity, clear the value tag for the master information block as well as all value tags for all system information blocks and forward that PLMN identity to upper layers.
- store the value tag of the master information block.
- check the IE value tag for all system information blocks which are to be used by the UE. If the value tag has been changed or if the system information block has not been read before, the UE shall store the scheduling information (SIB_REP and SIB_POS) valid for that system information block.

The SIB_REP and SIB_POS given by the master information block may be used by the UE to find the location of each system information block that will be acquired.

At reception of a system information block, the UE shall

- store the IE value tag (if that IE is present) or start a timer set to the value indicated in the IE expiration time (if that IE is present).
- store the remaining IEs in the system information block
- forward non-access stratum system information to upper layers

8.1.1.3.2 Reception of SYSTEM INFORMATION broadcast on a FACH transport channel

[The reception of system information blocks transmitted on a FACH transport channel is FFS.]

8.1.1.4 Modification of system information

The UE and UTRAN may use different mechanisms to update system information blocks. If the system information block contains a value tag, UTRAN shall indicate when any of the information elements are modified. If the system information block contains an expiration time, the UE is responsible for the re-reading of system information when the timer expires.

8.1.1.4.1 Modification of system information blocks using a value tag

When system information is modified, UTRAN shall perform the following actions:

- update the actual system information in the corresponding system information block.
- update the value tag in the system information block.
- start to repeat the updated system information block on the BCCH mapped on BCH or FACH instead of the old system information block.
- update the master information block. Both the value tag of the modified system information block and the value tag of the master information block need to be updated.
- send the new master information block on the BCCH mapped on FACH in order to reach all UEs in state CELL_FACH. UTRAN may repeat the new master information block on the FACH to increase the probability of proper reception in all UEs needing the information.

- send the new master information block on the BCCH mapped on BCH instead of the old master information block.
- send the message PAGING TYPE 1 on the PCCH in order to reach idle mode UEs as well as connected mode UEs in state CELL_PCH and URA_PCH. In the IE BCCH Modification Information, UTRAN shall indicate the new value tag for the master information block. The PAGING TYPE 1 message shall be sent in all paging occasions.

At reception of the PAGING TYPE 1 message, the UE shall

- check the value tag of the master information block indicated in the IE BCCH Modification information. If the value tag has been changed, the UE shall read the new master information block using the pre-defined scheduling information.

At reception of the new master information block (received on the BCCH mapped on BCH or FACH), the UE shall:

- store the new value tag of the master information block.
- check the IE value tag for all system information blocks which are used by the UE. If any of the value tags have been changed, the UE shall store the scheduling information valid for those system information blocks. Using the scheduling information, the UE is able to locate the modified system information block(s) and retrieve the new information.

8.1.1.4.2 Modification of system information blocks containing an expiration time

When the UE has acquired a system information block containing the IE expiration time, a timer shall be started using the value indicated in that IE. When the timer expires, the information carried in the system information block is considered to be old and the UE shall acquire new information before the values of the included system information elements can be used again.

8.1.2 Paging

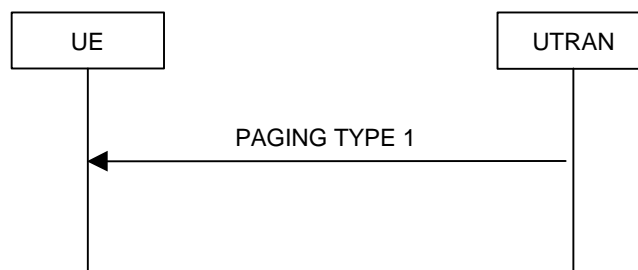

Figure 85. Paging

8.1.2.1 General

This procedure is used to transmit paging information to selected UEs in idle mode, CELL_PCH or URA_PCH state using the paging control channel (PCCH). Upper layers in the network may request paging, to e.g. establish a signalling connection. UTRAN may initiate paging in CELL_PCH or URA_PCH state, to trigger a UE state transition or reading of updated system information.

8.1.2.2 Initiation

Upper layers in the network may request paging of a UE. UTRAN initiates the paging procedure by broadcasting a PAGING TYPE 1 message on an appropriate paging occasion on the PCCH.

UTRAN may repeat paging of a UE in several paging occasions to increase the probability of proper reception of a page. This is a UTRAN option.

8.1.2.2.1 Message PAGING TYPE 1 contents to set

UTRAN may page several UEs in the same paging occasion by including one IE Paging record for each UE in the PAGING TYPE 1 message. The identity shall be set according to the following:

- For an idle mode UE the identity shall be set to a CN UE identity given by the non-access stratum.
- For an UE in connected mode (CELL_PCH or URA_PCH state) the identity shall be set to a U-RNTI.

UTRAN may also indicate updated system information, by including the value tag of the master information block in the IE BCCH modification information in the PAGING TYPE 1 message.

8.1.2.3 Reception of message PAGING TYPE 1 by the UE

The UE shall in idle mode, CELL_PCH state and URA_PCH state receive the paging information for all its monitored paging occasions. The paging occasions an idle mode UE shall monitor are specified in TS 25.304. For an UE in CELL_PCH state and URA_PCH state the paging occasions are specified in subclauses 9.3.3.3 and 9.3.4.3 respectively.

When the UE receives a PAGING TYPE 1 message as paging information, it shall check each occurrence of the IE Paging record and perform the actions as specified in subclause 8.1.2.3.1.

8.1.2.3.1 Message PAGING TYPE 1 contents to use

For each included paging record the UE shall compare the included identity with the identity of the UE according to the following:

- An idle mode UE shall compare the included identities of type CN UE identity with all of its allocated CN UE identities. For each match the UE shall forward the identity and paging cause to the upper layer entity indicated by the CN domain identity.
- A connected mode UE shall compare the included identities of type Connected mode identity with its allocated U-RNTI. If there is a match, the UE shall check the Paging originator and perform the following:
 - If paging originator is CN, the UE shall forward the identity and paging cause to the upper layer entity indicated by CN domain identity.
 - The UE shall store the paging cause to be included in the RRC connection establishment procedure.
 - If paging originator is UTRAN, the UE shall enter CELL_FACH state and perform a cell update procedure with cause paging response as specified in subclause 8.3.1.2.4.
- When there is no match the UE shall ignore that paging record.

If the IE BCCH modification info is included, the UE shall check the included value tag of the master information block and, if necessary, read system information on the BCCH as specified in subclause 8.1.1

8.1.3 RRC connection establishment

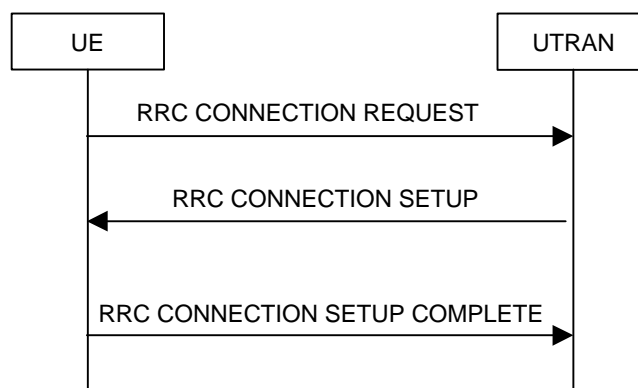

Figure 96) RRC Connection Establishment, network accepts RRC connection

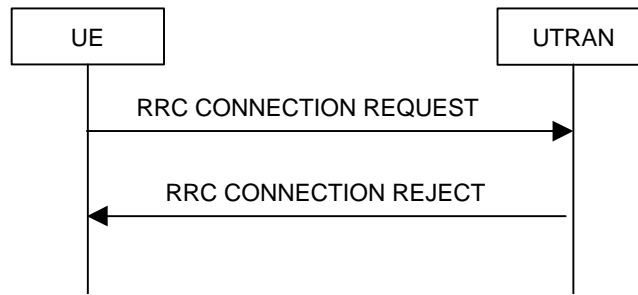

Figure 107) RRC Connection Establishment, network rejects RRC connection

8.1.3.1 General

The purpose with this procedure is to establish an RRC connection.

8.1.3.2 Initiation

The non-access stratum in the UE may request establishment of an RRC connection.

The UE shall transmit an RRC CONNECTION REQUEST message on the uplink CCCH, reset counter V300, and start timer T300.

8.1.3.2.1 Message RRC CONNECTION REQUEST contents to set

The UE shall set the IE Establishment cause'according to indications from the non-access stratum or according to the paging cause received from the PAGING TYPE 1 message.

The UE shall set the IE Initial UE identity'according to subclause 8.5.1

The UE shall indicate its capability in the IE Initial UE capability'.

The UE shall include an intra-frequency measurement report, as instructed to do so in the system information.

8.1.3.3 Reception of RRC CONNECTION REQUEST by the UTRAN

UTRAN shall either

- start timer T350 and transmit an RRC CONNECTION SETUP on the downlink CCCH or
- transmit an RRC CONNECTION REJECT on the downlink CCCH. On the UTRAN side, the procedure ends and all context information for this UE may be deleted in UTRAN.

8.1.3.3.1 Message RRC CONNECTION SETUP contents to set

The IE Initial UE identity'shall be set to the same value as in the received message RRC CONNECTION REQUEST.

[Editor's note: Other IEs are included and set according to selection by the UTRAN.]

8.1.3.3.2 Message RRC CONNECTION REJECT contents to set

The IE Initial UE identity'shall be set to the same value as in the received message RRC CONNECTION REQUEST.

8.1.3.4 Reception of RRC CONNECTION SETUP by the UE

The UE shall compare the value of the IE Initial UE identity'in the received RRC CONNECTION SETUP message with the value of the IE Initial UE identity'in the most recent RRC CONNECTION REQUEST message sent by the UE.

- If the values are identical, the UE shall stop timer T300, perform the actions according to subclause 8.1.3.4.1 and transmit an RRC CONNECTION SETUP COMPLETE message on the uplink DCCH. When the transmission of the RRC CONNECTION SETUP COMPLETE message has been confirmed by RLC the procedure ends.
- If the values are different, the UE shall ignore the rest of the message

8.1.3.4.1 Message RRC CONNECTION SETUP contents to use

The UE shall

- store the values of the IE U-RNTI and
- initiate the signalling link parameters according to the IEs Signalling link type and RAB multiplexing info.

If the IE C-RNTI is included, the UE shall

- use that C-RNTI on common transport channels in the current cell.

If neither the IEs PRACH info, nor Uplink DPCH info is included, the UE shall

- let the physical channel of type PRACH that is given in system information to be the default in uplink for RACH

If neither the IEs Secondary CCPCH info, nor Downlink DPCH info is included, the UE shall

- start to receive the physical channel of type Secondary CCPCH that is given in system information to be used as default by FACH, and enter the CELL_FACH state.

Actions that shall be performed by the UE for other IEs are specified in subclause 8.5.7

8.1.3.4.2 Message RRC CONNECTION SETUP COMPLETE contents to set

The UE shall include its capabilities in the RRC CONNECTION SETUP COMPLETE message, according to instructions in the system information.

8.1.3.5 Abnormal cases: Physical channel failure or T300 timeout

- Upon expiry of timer T300, or
- if the UE failed to establish the physical channel(s) indicated in the message RRC CONNECTION SETUP

the UE shall check the value of V300, and

- if V300 is smaller or equal than N300, the UE shall transmit a new RRC CONNECTION REQUEST message on the uplink CCCH, restart timer T300 and increase counter V300. The UE shall set the IEs in the RRC CONNECTION REQUEST message according to subclause 8.1.3.2.1
- If V300 is greater than N300, the UE shall enter idle mode. The procedure ends and a connection failure may be indicated to the non-access stratum. Other actions the UE shall perform when entering idle mode from connected mode are specified in subclause 8.5.2

8.1.3.6 Reception of RRC CONNECTION REJECT by the UE

When the UE receives an RRC CONNECTION REJECT message on the downlink CCCH, it shall compare the value of the IE Initial UE identity in the received RRC CONNECTION SETUP message with the value of the IE Initial UE identity in the last RRC CONNECTION REQUEST message sent by the UE.

- If the values are identical, the UE shall stop timer T300 and perform the actions in subclause 8.1.3.6.1
- If the values are different, the UE shall ignore the rest of the message

8.1.3.6.1 Message RRC CONNECTION REJECT contents to use

If the IE Wait time is present, and

- if V300 is smaller or equal than N300, the UE shall wait at least the time stated in the IE Wait time, transmit a new RRC CONNECTION REQUEST message on the uplink CCCH, restart timer T300 and increase counter V300. UE shall set the IEs in the RRC CONNECTION REQUEST message according to subclause 8.1.3.2.1
- If V300 is greater than N300 the UE shall enter idle mode. The procedure ends and a connection failure may be indicated to the non-access stratum. Other actions the UE shall perform when entering idle mode from connected mode are specified in subclause 8.5.2

If the IE Wait time is not present the UE shall

- enter idle mode. The procedure ends and a connection failure may be indicated to the non-access stratum. Other

actions the UE shall perform when entering idle mode from connected mode are specified in subclause 8.5.2

8.1.3.7 Reception of RRC CONNECTION SETUP COMPLETE by the UTRAN

When UTRAN has received the RRC CONNECTION SETUP COMPLETE message, the procedure ends on the UTRAN side, and timer T350 shall be stopped.

8.1.3.8 Abnormal case: T350 timeout

Upon expiry of timer T350, the procedure ends on the UTRAN side, and all context information for this UE may be deleted in UTRAN.

8.1.4 RRC connection release

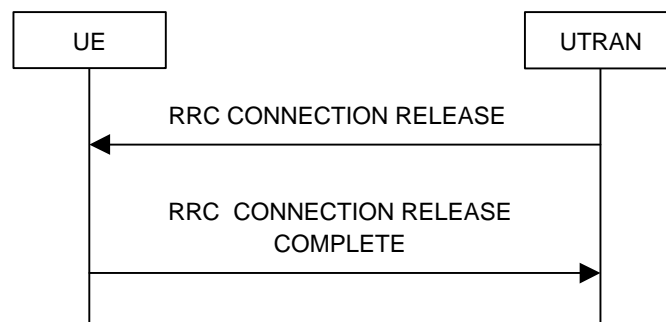

Figure 118. RRC Connection Release procedure

8.1.4.1 General

The purpose with this procedure is to release the RRC connection including the signalling link and all radio bearers between the UE and the UTRAN.

8.1.4.2 Initiation

When the UE is in state Cell_DCH or Cell_FACH, the UTRAN can anytime initiate a RRC connection release by transmitting an RRC CONNECTION RELEASE message using unacknowledged mode.

8.1.4.2.1 Retransmission of message RRC CONNECTION RELEASE

UTRAN may transmit several RRC CONNECTION RELEASE messages to increase the probability of proper reception of the message by the UE. The number of repeated messages and the interval between the messages is a network option.

8.1.4.3 Reception of RRC CONNECTION RELEASE by the UE

The UE shall be able to receive and act on RRC CONNECTION RELEASE in states Cell_DCH and Cell_FACH. Furthermore this procedure can interrupt any ongoing procedures with the UE in the above listed states.

When the UE receives the first RRC CONNECTION RELEASE message, it shall

- When in state CELL_DCH, transmit an RRC CONNECTION RELEASE COMPLETE message using unacknowledged mode to the UTRAN and start timer T308.
- When in state CELL_FACH, transmit an RRC CONNECTION RELEASE COMPLETE message using acknowledged mode to the UTRAN

Any succeeding RRC CONNECTION RELEASE messages that are received by the UE shall be ignored.

A release indication should be given to the non-access stratum.

8.1.4.3.1 Message RRC CONNECTION RELEASE contents to use

The IE Number of RRC Message Transmissions' indicates the number of times to send the message RRC CONNECTION RELEASE COMPLETE and the UE shall initialise the counter V308 with the value of this IE when in CELL_DCH state.

8.1.4.4 CELL_DCH: Expiry of timer T308

When in state CELL_DCH and the timer T308 expires, the UE shall decrease V308 by one. If V308 is greater than zero, the UE shall repeat the RRC CONNECTION RELEASE COMPLETE message. If V308 is equal to zero, the UE shall release all its radio resources, enter idle mode and the procedure ends on the UE side. Actions the UE shall perform when entering idle mode are given in subclause 8.5.2

8.1.4.5 CELL_FACH: Successful transmission of RRC CONNECTION RELEASE COMPLETE

When the UE is in state CELL_FACH and RLC has confirmed the transmission of the RRC CONNECTION RELEASE COMPLETE message it shall release all its radio resources, enter idle mode and the procedure ends on the UE side. Actions the UE shall perform when entering idle mode are given in subclause 8.5.2

8.1.4.6 Reception of RRC CONNECTION RELEASE COMPLETE by UTRAN

When UTRAN receives a RRC CONNECTION RELEASE COMPLETE message from the UE, it should release all UE dedicated resources and the procedure ends on the UTRAN side.

8.1.4.7 CELL_FACH abnormal case: unsuccessful transmission of RRC CONNECTION RELEASE COMPLETE

When the UE is in state CELL_FACH and does not succeed to transmit the RRC CONNECTION RELEASE COMPLETE message, it shall release all its radio resources, enter idle mode and the procedure ends on the UE side. Actions the UE shall perform when entering idle mode are given in subclause 8.5.2

8.1.4.8 CELL_DCH abnormal case: detection of dedicated physical channel release by UTRAN

If the release is performed from the state CELL_DCH, and UTRAN detects loss of a the dedicated physical channel according to subclause 8.5.6, UTRAN may release all UE dedicated resources, even if no RRC CONNECTION RELEASE COMPLETE message has been received.

8.1.4.9 Abnormal case: no reception of RRC CONNECTION RELEASE COMPLETE by UTRAN

If UTRAN does not receive any RRC CONNECTION RELEASE COMPLETE message, it should release all UE dedicated resources.

8.1.5 RRC connection re-establishment

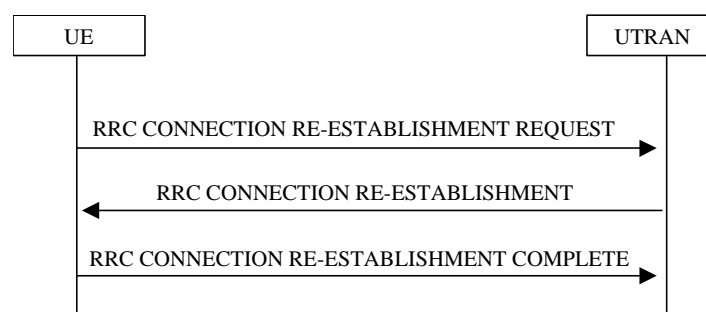

Figure 129. RRC Connection Re-establishment, successful case

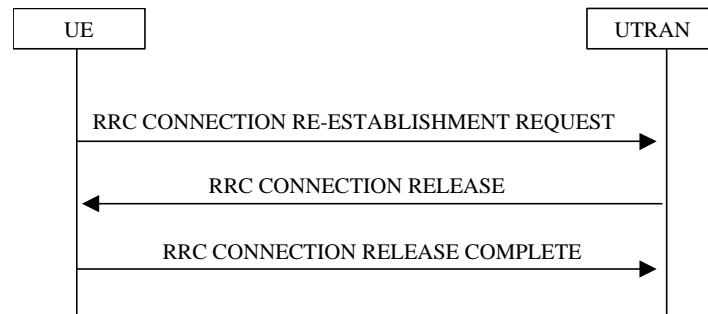

Figure 1340. RRC Connection Re-establishment, failure case

8.1.5.1 General

The purpose with this procedure is to re-establish an RRC connection.

8.1.5.2 Initiation

When a UE loses the radio connection due to e.g. radio link failure in CELL_DCH state, the UE may initiate a new cell selection by transiting to CELL_FACH state and request re-establishment of an RRC connection.

The UE shall transmit an RRC CONNECTION RE-ESTABLISHMENT REQUEST message on the uplink CCCH, reset counter V301, and start timer T301.

8.1.5.2.1 Message RRC CONNECTION RE-ESTABLISHMENT REQUEST contents to set

The UE shall

- Set the IE U-RNTI, which the UE has in itself.
- Include an intra-frequency measurement report, as instructed to do so in the system information.

8.1.5.3 Reception of RRC CONNECTION RE-ESTABLISHMENT REQUEST by the UTRAN

UTRAN shall either

- start timer T352 and transmit an RRC CONNECTION RE-ESTABLISHMENT on the downlink DCCH on FACH or
- initiate RRC Connection Release procedure in CELL_FACH state when the UTRAN cannot accept RRC Connection Re-establishment from the UE.

8.1.5.3.1 Message RRC CONNECTION RE-ESTABLISHMENT contents to set

If transport channels are added, reconfigured or deleted in uplink and/or downlink, the UTRAN shall

- Set TFCS according to the new transport channel(s)

If activation time is used this time shall not be set to a larger value than T352.

[Editor's note: Other IEs are included and set according to selection by the UTRAN.]

8.1.5.3.2 Message RRC CONNECTION RELEASE contents to set

The UTRAN shall

- set IE Release Cause, according to the condition in UTRAN.

8.1.5.4 Reception of RRC CONNECTION RE-ESTABLISHMENT by the UE

The UE shall

- Stop timer T301
- Re-establish the RRC Connection according to the IEs included in the RRC CONNECTION RE-ESTABLISHMENT message and transmit a RRC CONNECTION RE-ESTABLISHMENT COMPLETE message on the uplink DCCH using AM RLC.

8.1.5.4.1 Message RRC CONNECTION RE-ESTABLISHMENT contents to use

The UE shall

- For each reconfigured radio bearer use the multiplexing option applicable for the transport channels used according to the IE RB multiplexing info”
- Configure MAC multiplexing if that is needed in order to use said transport channel(s).
- Use MAC logical channel priority when selecting TFC in MAC.

If neither the IEs PRACH info”nor Uplink DPCH info”is included, the UE shall

- Let the physical channel of type PRACH that is given in system information be the default in uplink and enter the CELL_FACH state.

If neither the IEs Secondary CCPCH info”nor Downlink DPCH info”is included, the UE shall

- Start to receive the physical channel of type Secondary CCPCH that is given in system information.

The UE shall use the transport channel(s) applicable for the physical channel types that is used. If neither the IE TFS”is included or previously stored in the UE for that transport channel(s), the UE shall

- Use the TFS given in system information

If none of the TFS stored is compatible with the physical channel, the UE shall

- Delete stored TFS and use the TFS given in system information

If the IE C-RNTI is included, the UE shall

- Use that C-RNTI when using common transport channels of type RACH, FACH and CPCH in the current cell.

If the the "U-RNTI" IE is included, the UE shall update its identity.

If the CN domain identity”and NAS system information”are included, the UE shall

- forward the content of the IE to the non-access stratum entity of the UE indicated by the IE CN domain identity.”

Actions that shall be performed by the UE, for other IEs are specified in chapter 8.5.7.

8.1.5.4.2 Message RRC CONNECTION RE-ESTABLISHMENT COMPLETE contents to set

The UE shall

- FFS.

8.1.5.5 Abnormal cases: T301 timeout or DPCH failure

- Upon expiry of timer T301, or
- if the UE failed to re-establish the RRC Connection indicated in the message RRC CONNECTION RE-ESTABLISHMENT

the UE shall check the value of V301, and

- if V301 is smaller or equal than N301, the UE shall transmit a new RRC CONNECTION RE-ESTABLISHMENT

REQUEST message on the uplink CCCH, restart timer T301 and increase counter V301. The UE shall set the IEs in the RRC CONNECTION RE-ESTABLISHMENT REQUEST message according to subclause 8.1.5.2.1

- If V301 is greater than N301, the UE shall enter idle mode. The procedure ends and a connection failure may be indicated to the non-access stratum. Other actions the UE shall perform when entering idle mode from connected mode are specified in subclause 8.5.2

8.1.5.6 Reception of RRC CONNECTION RE-ESTABLISHMENT COMPLETE by the UTRAN

When UTRAN has received the RRC CONNECTION RE-ESTABLISHMENT COMPLETE message, the procedure ends on the UTRAN side, and timer T352 shall be stopped.

8.1.5.7 Abnormal case: T352 timeout

Upon expiry of timer T352, the procedure ends on the UTRAN side, and all context information for this UE may be deleted in UTRAN.

8.1.6 Transmission of UE capability information

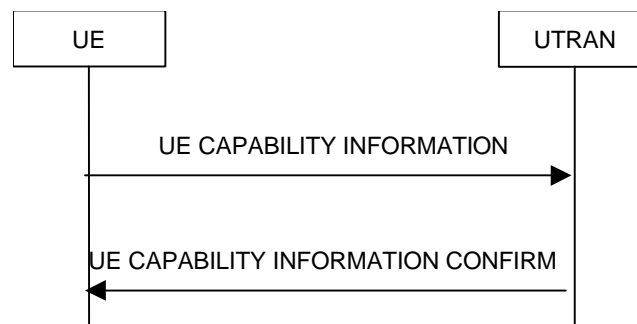

Figure 1411. Transmission of UE capability information, normal flow

8.1.6.1 General

The UE capability update procedure is used by the UE to convey UE specific capability information to the UTRAN.

8.1.6.2 Initiation

The UE shall initiate the UE capability update procedure in the following situations:

- Upon capability enquiry from the UTRAN, after the UE has received a UE CAPABILITY ENQUIRY message from the UTRAN.
- After having performed cell reselection to a cell, where the "capability update requirement" indicates the necessity to transmit capability information which has not been previously sent.
- If UE capabilities change during the RRC connection. (E.g. change of power class)

The UE transmits the UE CAPABILITY INFORMATION message on the uplink DCCH using AM or UM RLC, starts timer T304 and resets counter V304.

8.1.6.2.1 Message UE CAPABILITY INFORMATION contents to set

If the UE CAPABILITY INFORMATION is sent upon establishment of an RRC connection, the UE shall

- shall set CN specific capability information into the "NAS message" IE and UTRAN specific capability information to the corresponding information elements according to information stored in the UE.
- include one or more inter-system classmarks into "inter-system message" IEs, according to the requirement given in the "Capability update requirement" IE in the SYSTEM INFORMATION message

If the UE CAPABILITY INFORMATION is sent in response to a UE CAPABILITY ENQUIRY message, the UE shall

- include the UMTS specific UE capability information elements if requested in the "Capability update requirement" IE in the UE CAPABILITY ENQUIRY message.
- include one or more inter-system classmarks into "inter-system message" IEs, according to the requirement given in the "Capability update requirement" IE in the UE CAPABILITY ENQUIRY message

8.1.6.3 Reception of UE CAPABILITY INFORMATION by the UTRAN

Upon reception of a UE CAPABILITY INFORMATION message, the UTRAN shall transmit a UE CAPABILITY INFORMATION CONFIRM message on the downlink DCCH using UM or AM RLC. After the UE CAPABILITY INFORMATION CONFIRM message has been sent, the procedure is complete.

8.1.6.3.1 Message UE CAPABILITY INFORMATION contents to use

- The UTRAN shall store the capability information received from the UE.
- The UTRAN specific capability information elements are stored to be further used for the configuration of UTRAN specific services for the UE.
- The "NAS message" including CN specific capability information is forwarded to the CN.
- The "inter-system message" including the inter-system classmark is stored to be further used for configuration of inter-system measurements and in the execution of inter-system handover.

8.1.6.3.2 Message UE CAPABILITY INFORMATION CONFIRM contents to set

[Editor's note: Currently only a message type IE is included in this message.]

8.1.6.4 Reception of UE CAPABILITY INFORMATION CONFIRM by the UE

Upon reception of a UE CAPABILITY INFORMATION CONFIRM message, the UE shall stop timer T304. It shall then update its register on which UE capabilities it has transmitted to the UTRAN during the current RRC connection.

8.1.6.5 Abnormal case: T304 timeout

Upon expiry of timer T304 and no UE CAPABILITY INFORMATION CONFIRM message has been received, the UE shall check the value of V304 and

- If V304 is smaller or equal than N304, the UE shall retransmit a UE CAPABILITY INFORMATION message, restart timer T304 and increase counter V304.
- If V304 is greater than N304, the UE shall assume that radio link failure has occurred and initiate the RRC connection re-establishment procedure

8.1.7 UE capability enquiry

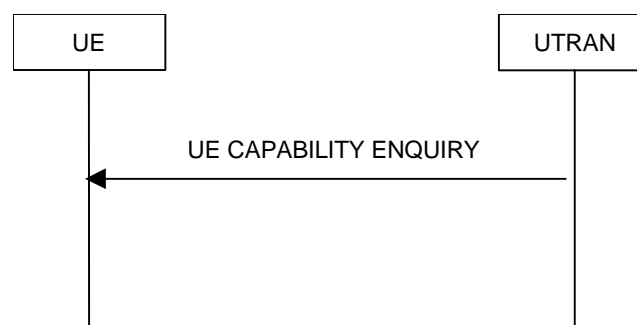

Figure 1512. UE capability enquiry procedure, normal flow

8.1.7.1 General

The UE capability enquiry can be used to request the UE to transmit its capability information related to any radio access network that is supported by the UE. In particular, it can be used by the UTRAN to request an update of inter-system capability information from a dual mode terminal.

8.1.7.2 Initiation

The UTRAN initiates the UE capability enquiry procedure, if it needs an update of the UE's UMTS capability information or of its inter-system classmark.

The UTRAN shall transmit the UE CAPABILITY ENQUIRY message on the DCCH using the UM or AM SAP.

Message UE CAPABILITY ENQUIRY contents to set

The UTRAN shall indicate in the "Capability update requirement" IE, which inter-system classmarks, if any, should be updated, and if it also needs an update of UMTS capability information.

8.1.7.3 Reception of message UE CAPABILITY ENQUIRY by the UE

Upon reception of UE CAPABILITY ENQUIRY, the UE shall initiate the transmission of UE capability information, which is specified in clause 8.1.6

8.1.7.4 Abnormal case

[Editor's question: Is it useful to specify the UTRAN behaviour in detail for this procedure? This may be covered by the more general rules of handling radio link failure in connected mode.]

8.1.8 Direct transfer

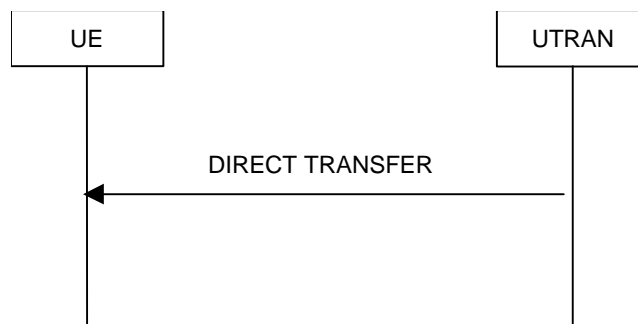

Figure 1613. Direct transfer in the downlink, normal flow

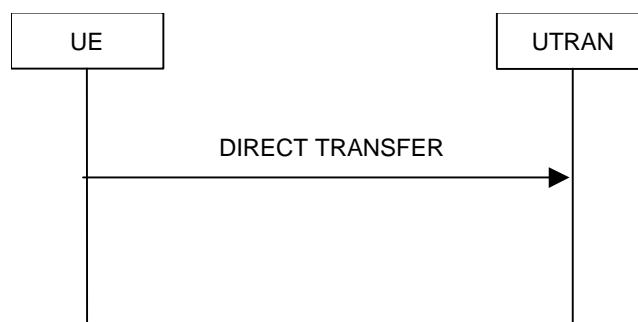

Figure 1714. Direct transfer in the uplink, normal flow

8.1.8.1 General

The direct transfer procedure is used in both downlink and uplink to carry all higher layer (NAS) messages over the radio interface. It can also be used to establish and release signalling connections (FFS).

8.1.8.2 Initiation of direct transfer procedure in the UE

In the UE, the direct transfer procedure shall be initiated, when the upper layers request a transfer of a NAS message. The UE shall transmit the DIRECT TRANSFER message on the uplink DCCH using AM or UM RLC.

8.1.8.2.1 Message DIRECT TRANSFER (uplink) contents to set

The UE shall set "CN domain identifier" to indicate, which CN node the NAS message is destined to.

In, CELL_FACH state, The UE shall include "Measured results" into the DIRECT TRANSFER message, if the message is sent to establish a signalling connection and if RACH measurement reporting has been requested in the SYSTEM INFORMATION message.

8.1.8.3 Initiation of direct transfer procedure in the UTRAN

In the UTRAN, the direct transfer procedure shall be initiated, when the upper layers request the transfer of a NAS message or the release of a signalling connection (FFS)(.. The UE shall transmit the DIRECT TRANSFER message on the downlink DCCH using AM or UM RLC.

8.1.8.3.1 Message DIRECT TRANSFER (downlink) contents to set

The UTRAN sets "CN domain identifier" to indicate, which CN domain the NAS message is originated from.

8.1.8.4 Reception of DIRECT TRANSFER in the UTRAN

Upon reception of the DIRECT TRANSFER message the NAS message shall be routed to the correct CN domain.

8.1.8.4.1 Message DIRECT TRANSFER (uplink) contents to use

The UTRAN routes the contents of the "NAS message" IE to the correct CN domain using the "CN domain identifier" IE.

If the "measured results" IE is present in the message, the UTRAN shall extract the contents to be used for radio resource control.

8.1.8.5 Reception of DIRECT TRANSFER by the UE

Upon reception of the DIRECT TRANSFER message, the UE RRC shall

- route the contents of the higher layer PDU, if any, to the correct higher layer entity.
- route the signalling connection release indication, if any, to the correct higher layer entity (FFS).

8.1.8.5.1 Message DIRECT TRANSFER (downlink) contents to use

The UE RRC routes the contents of the "NAS message" IE to the correct higher layer entity using the "CN domain identifier" IE.

8.1.8.6 Abnormal cases

[Delivery of DIRECT TRANSFER messages is guaranteed by the the higher layers and, optionally, the acknowledged service in the RLC layer.]

8.1.9 Connected mode paging on DCCH

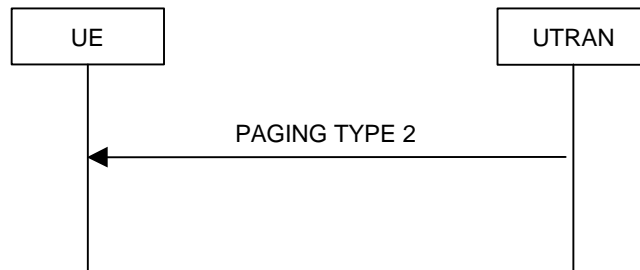

Figure 1815. Connected mode paging on DCCH

8.1.9.1 General

This procedure is used to transmit paging information to selected UEs in connected mode in states CELL_DCH and CELL_FACH. Upper layers in the network may request paging, to e.g. establish a signalling connection.

8.1.9.2 Initiation

Upper layers in the network may request paging of an UE. For an UE in states CELL_DCH or CELL_FACH, UTRAN initiates the procedure by transmitting a PAGING TYPE 2 message on the DCCH.

8.1.9.2.1 Message PAGING TYPE 2 contents to set

The IEs 'Paging cause' and 'Paging record type identifier' shall be set according to indications from the upper layers.

8.1.9.3 Reception of message PAGING TYPE 2 by the UE

The UE shall indicate paging and forward the paging cause and the paging record type identifier to the upper layer entity indicated by the CN domain identity.

8.1.10 Security mode control

<note: this procedure should be updated in line with the agreed structure>

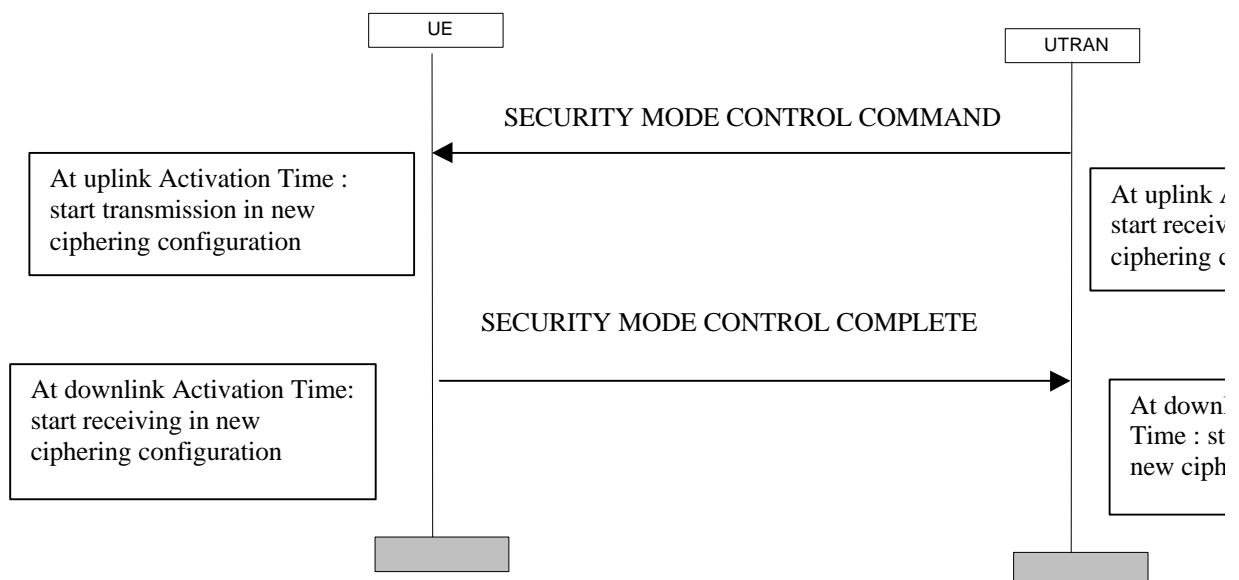

Figure 1916) Security mode control procedure

This procedure is used to trigger the start of ciphering, or to command the change of the cipher key, both for the signalling link and for a user plane connection. The ciphering is configured in both directions.

The SRNC sends a SECURITY MODE CONTROL COMMAND to the UE, which indicates the uplink Activation Time when the ciphering shall start to be applied in uplink. The SRNC then starts to decipher in the new ciphering configuration at the uplink Activation Time.

When the UE receives the SECURITY MODE CONTROL COMMAND message, it starts ciphering transmission in the uplink in the new configuration at the uplink Activation Time. It sends a SECURITY MODE CONTROL COMPLETE message, which includes a downlink Activation Time, and starts to receive in the new ciphering configuration at that Activation Time. When the SRNC receives the SECURITY MODE CONTROL COMPLETE, it starts ciphering transmission in the new configuration at the downlink Activation Time.

Note : The same procedure can be used for integrity control. But this is FFS.

8.2 Radio Bearer control procedures

8.2.1 Radio bearer establishment

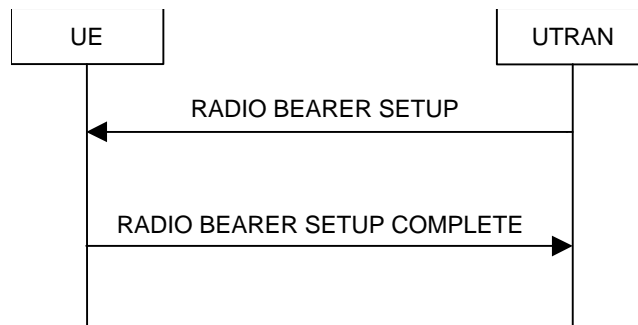

Figure 2017. Radio Bearer Establishment, normal case

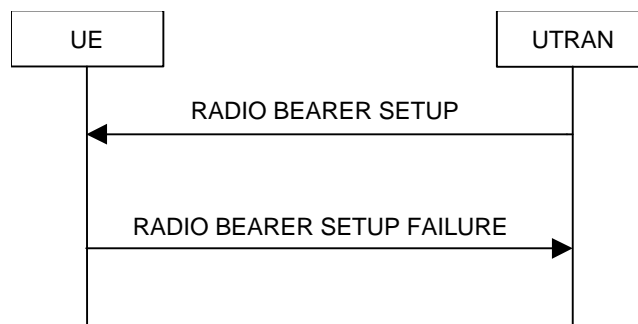

Figure 2118. Radio Bearer Establishment, UE reverts to old configuration

8.2.1.1 General

The purpose with this procedure is to establish new radio bearer(s). A DCH which carries transparent mode DCCH information to control, e.g. the TFCS, may also be defined.

8.2.1.2 Initiation

The upper layer in the network may request an establishment of radio bearer(s).

UTRAN shall transmit a RADIO BEARER SETUP message on the downlink DCCH using AM or UM RLC, and start timer T353.

8.2.1.2.1 Message RADIO BEARER SETUP contents to set

If transport channels are added, reconfigured or deleted in uplink and/or downlink, UTRAN shall

- Set TFCS according to the new transport channel(s)

If activation time is used this time shall not be set to a larger value than T353.

UTRAN should take the UE capabilities into account when setting the new configuration.

[Editor's note: Other IEs are included and set according to selection by the UTRAN.]

8.2.1.3 Reception of RADIO BEARER SETUP by the UE

Upon reception of a RADIO BEARER SETUP message the UE shall perform actions according to subclause 8.2.1.3.1 and transmit a RADIO BEARER SETUP COMPLETE message on the uplink DCCH using AM RLC. When the transmission of the RADIO BEARER SETUP COMPLETE message has been confirmed by RLC the procedure ends.

8.2.1.3.1 Message RADIO BEARER SETUP contents to use

The UE shall

- For the new radio bearer(s), use the multiplexing option applicable for the transport channels used according to the IE RB mapping info”
- For radio bearer(s) existing prior to the message, use the multiplexing option applicable for the transport channels used, according to their IE RB mapping info”or their previously stored multiplexing options.
- Configure MAC multiplexing if that is needed in order to use said transport channel(s).
- Use MAC logical channel priority when selecting TFC in MAC.

If the IE C-RNTI is included, the UE shall

- Use that C-RNTI when using common transport channels of type RACH, FACH and CPCH in the current cell.

If neither the IEs PRACH info”nor Uplink DPCH info”is included, the UE shall

- Let the physical channel of type PRACH that is given in system information be the default in uplink and enter the CELL_FACH state.

If neither the IEs Secondary CCPCH info”nor Downlink DPCH info”is included, the UE shall

- Start to receive the physical channel of type Secondary CCPCH that is given in system information.

The UE shall use the transport channel(s) applicable for the physical channel types that is used. If neither the IE TFS”is included or previously stored in the UE for that transport channel(s), the UE shall

- Use the TFS given in system information

If none of the TFS stored is compatible with the physical channel, the UE shall

- Delete stored TFS and use the TFS given in system information

Actions that shall be performed by the UE, for other IEs are specified in subclause 8.5.7

8.2.1.3.2 Message RADIO BEARER SETUP COMPLETE contents to set

FFS

8.2.1.4 Abnormal case: Unsupported configuration in the UE

If UTRAN instructs the UE to use a configuration that it does not support, the UE shall

- Transmit a RADIO BEARER SETUP FAILURE message on the DCCH using AM RLC.

8.2.1.4.1 Message RADIO BEARER SETUP FAILURE contents to set

The UE shall set the cause value in IE failure cause”to ‘configuration unacceptable.’

8.2.1.5 Abnormal cases: Physical channel failure

If the UE failed to establish the physical channel(s) indicated in the message RADIO BEARER SETUP the UE shall

- Revert to the configuration prior to the reception of the RADIO BEARER SETUP message (old configuration) and transmit a RADIO BEARER SETUP FAILURE message on the DCCH using AM RLC. The procedure ends and the UE resumes the normal operation as if no radio bearer establishment attempt had occurred.

Criteria to be fulfilled for having a physical channel established are described in subclause 8.5.4

If the UE is unable to revert to the old configuration or if used, the activation time has expired, the UE shall

- Initiate a RRC connection re-establishment procedure according to subclause 8.1.5

8.2.1.5.1 Message RADIO BEARER SETUP FAILURE contents to set

The UE shall set the cause value in IE failure cause to 'physical channel failure'.

8.2.1.6 Reception of RADIO BEARER SETUP COMPLETE by the UTRAN

When UTRAN has received the RADIO BEARER SETUP COMPLETE message, UTRAN may delete any old configuration. Timer T353 is stopped and the procedure ends on the UTRAN side.

8.2.1.7 Reception of RADIO BEARER SETUP FAILURE by the UTRAN

When UTRAN has received the RADIO BEARER SETUP FAILURE message, UTRAN may delete the new configuration. Timer T353 is stopped and the procedure ends on the UTRAN side. Upper layers should be notified of the failure.

8.2.1.8 Abnormal case: T353 timeout

Upon expiry of timer T353 and no RADIO BEARER SETUP COMPLETE or RADIO BEARER SETUP FAILURE message has been received, the UTRAN may delete the old and new configuration. All UE dedicated resources may then be cleared, unless the UE requests a re-establishment of the RRC connection.

8.2.2 Radio bearer reconfiguration

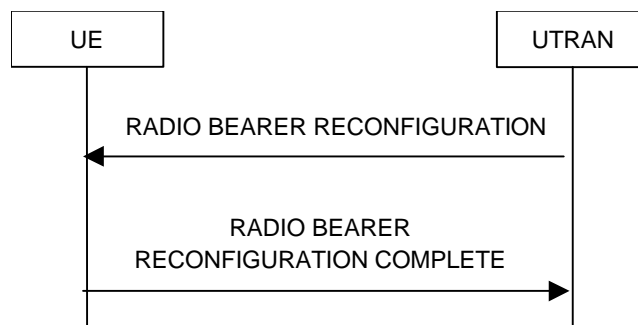

Figure 2219. Radio bearer reconfiguration, normal flow

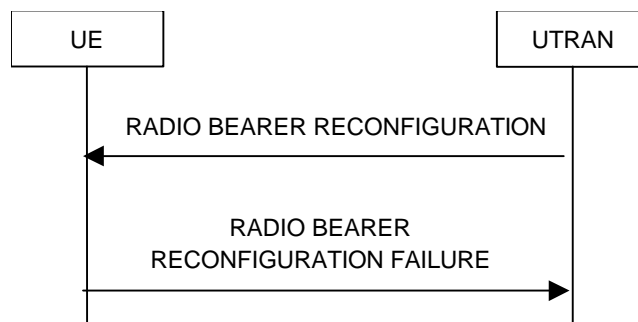

Figure 2320. Radio bearer reconfiguration, failure case

8.2.2.1 General

The radio bearer reconfiguration procedure is used to reconfigure parameters for a radio bearer or the signalling link to reflect a change in QoS.

8.2.2.2 Initiation

The UTRAN shall transmit a RADIO BEARER RECONFIGURATION message on the downlink DCCH using AM or UM RLC, and start timer T355.

8.2.2.2.1 Message RADIO BEARER RECONFIGURATION contents to set

If transport channels are added, reconfigured or deleted in uplink and/or downlink, the UTRAN shall

- Set TFCS according to the new transport channel(s)
- Indicate for each reconfigured bearer, whether uplink transmission is suspended. The suspension of uplink transmission on a signalling bearer is not applicable.

If activation time is used this time shall not be set to a larger value than T355.

UTRAN should take the UE capabilities into account when setting the new configuration.

[Editor's note: Other IEs are included and set according to selection by the UTRAN.]

If the message is used to initiate a transition from CELL_DCH to CELL_FACH state, the UTRAN may assign a common channel configuration of a given cell and C-RNTI to be used in that cell to the UE.

8.2.2.3 Reception of RADIO BEARER RECONFIGURATION by the UE in CELL_DCH state

Upon reception of a RADIO BEARER RECONFIGURATION message in CELL_DCH state, the UE shall perform actions according to subclause 8.2.2.3.1 and transmit a RADIO BEARER RECONFIGURATION COMPLETE message on the uplink DCCH using AM RLC. When the transmission of the RADIO BEARER RECONFIGURATION COMPLETE message has been confirmed by RLC, the procedure ends.

If the RADIO BEARER RECONFIGURATION message is used to initiate a transition from CELL_DCH to CELL_FACH state, the RADIO BEARER RECONFIGURATION COMPLETE message shall be transmitted on the RACH after the UE has completed the state transition.

8.2.2.3.1 Message RADIO BEARER RECONFIGURATION contents to use in CELL_DCH state

The UE shall

- For each reconfigured radio bearer or signalling link, use the multiplexing option applicable for the transport channels used according to the IE RB mapping info"
- Configure MAC multiplexing if that is needed in order to use said transport channel(s).
- Use MAC logical channel priority when selecting TFC in MAC.
- Suspend or resume uplink transmission for each radio bearer, as indicated by the "RB suspend/resume" information element.

If neither the IEs PRACH info" nor Uplink DPCH info" is included, the UE shall

- Let the physical channel of type PRACH that is given in system information be the default in uplink and enter the CELL_FACH state.

If neither the IEs Secondary CCPCH info" nor Downlink DPCH info" is included, the UE shall

- Start to receive the physical channel of type Secondary CCPCH that is given in system information.

The UE shall use the transport channel(s) applicable for the physical channel types that is used. If neither the IE TFS" is included or previously stored in the UE for that transport channel(s), the UE shall

- Use the TFS given in system information

If none of the TFS stored is compatible with the physical channel, the UE shall

- Delete stored TFS and use the TFS given in system information

Actions that shall be performed by the UE, for other IEs are specified in subclause 8.5.7

If the RADIO BEARER RECONFIGURATION message is used to initiate a state transition to the CELL_FACH state and if an IE primary CCPCH info and C-RNTI to a given cell is included, the UE shall

- Select the cell indicated by the PCCPCH info IE.
- Use the C-RNTI when using common transport channels of type RACH, FACH and CPCH in that given cell after having completed the transition to that cell.

8.2.2.3.2 Message RADIO BEARER RECONFIGURATION COMPLETE contents to set in CELL_DCH state

FFS.

8.2.2.4 Reception of RADIO BEARER RECONFIGURATION by the UE in CELL_FACH state

Upon reception of a RADIO BEARER RECONFIGURATION message in CELL_DCH state, the UE shall perform actions according to 8.2.2.4.1 and transmit a RADIO BEARER RECONFIGURATION COMPLETE message on the uplink DCCH using AM RLC. When the transmission of the RADIO BEARER RECONFIGURATION COMPLETE message has been confirmed by RLC, the procedure ends.

8.2.2.4.1 Message RADIO BEARER RECONFIGURATION contents to use in CELL_FACH state.

The UE shall

- For each reconfigured radio bearer or signalling link, use the multiplexing option applicable for the transport channels used according to the IE RB mapping info”
- Configure MAC multiplexing if that is needed in order to use said transport channel(s).
- Use MAC logical channel priority when selecting TFC in MAC.
- Suspend or resume uplink transmission for each radio bearer, as indicated by the "RB suspend/resume" information element.

If the IE C-RNTI is included, the UE shall

- Use that C-RNTI when using common transport channels of type RACH, FACH and CPCH in the current cell.

If neither the IEs PRACH info nor Uplink DPCH info is included, the UE shall

- Let the physical channel of type PRACH that is given in system information be the default in uplink

If neither the IEs Secondary CCPCH info nor Downlink DPCH info is included, the UE shall

- Start to receive the physical channel of type Secondary CCPCH that is given in system information.

The UE shall use the transport channel(s) applicable for the physical channel types that is used. If neither the IE TFS is included or previously stored in the UE for that transport channel(s), the UE shall

- Use the TFS given in system information

If none of the TFS stored is compatible with the physical channel, the UE shall

- Delete stored TFS and use the TFS given in system information

Actions that shall be performed by the UE, for other IEs are specified in subclause 8.5.7

8.2.2.4.2 Message RADIO BEARER RECONFIGURATION COMPLETE contents to set in CELL_FACH state

FFS.

8.2.2.5 Reception of RADIO BEARER RECONFIGURATION COMPLETE by the UTRAN

When UTRAN has received the RADIO BEARER RECONFIGURATION COMPLETE message, UTRAN may delete the old configuration. Timer T355 is stopped and the procedure ends on the UTRAN side.

8.2.2.6 Abnormal case: Unsupported configuration in the UE

If the UTRAN instructs the UE to use a configuration which it does not support, the UE shall

- transmit a RADIO BEARER RECONFIGURATION FAILURE message on the DCCH using AM RLC.

8.2.2.6.1 Message RADIO BEARER RECONFIGURATION FAILURE contents to set

The UE shall set the cause value in IE "failure cause" to "configuration unacceptable".

8.2.2.7 Abnormal case: Physical channel failure

If the UE failed to establish the physical channel(s) indicated in the message RADIO BEARER RECONFIGURATION the UE shall

- Revert to the configuration prior to the reception of the RADIO BEARER RECONFIGURATION message (old configuration) and transmit a RADIO BEARER RECONFIGURATION FAILURE message on the DCCH using AM RLC. The procedure ends and the UE resumes the normal operation as if no radio bearer reconfiguration attempt had occurred.

Criteria to be fulfilled for having a physical channel established are described in subclause 8.5.4

If the UE is unable to revert to the old configuration or if used, the activation time has expired, the UE shall

- Initiate a RRC connection re-establishment procedure according to subclause 8.1.5

8.2.2.7.1 Message RADIO BEARER RECONFIGURATION FAILURE contents to set

The UE shall set the cause value in IE "failure cause" to "physical channel failure".

8.2.2.8 Reception of RADIO BEARER RECONFIGURATION FAILURE by the UTRAN

When UTRAN has received the RADIO BEARER RECONFIGURATION FAILURE message, UTRAN may delete the new configuration. Timer T355 is stopped and the procedure ends on the UTRAN side. Upper layers should be notified of the failure.

8.2.2.9 Abnormal case: T355 timeout in CELL_DCH_state

Upon expiry of timer T355 in CELL_DCH state and no RADIO BEARER RECONFIGURATION COMPLETE or RADIO BEARER RECONFIGURATION FAILURE message has been received, the UTRAN may delete the old and new configuration. If the UE requests a re-establishment of the RRC connection, before all UE dedicated resources have been cleared, the new configuration may be re-assigned in the re-establishment procedure.

During transition from CELL_DCH to CELL_FACH, the UTRAN may also receive an CELL UPDATE message if the UE cannot use the assigned physical channel.

8.2.2.10 Abnormal case: T355 timeout in CELL_FACH state

Upon expiry of timer T355 and no RADIO BEARER RECONFIGURATION COMPLETE or RADIO BEARER RECONFIGURATION FAILURE message has been received, the UTRAN may delete the old and new configuration. If the UE makes a cell update before all UE dedicated resources have been cleared, the configuration procedure can be restarted.

8.2.2.11 Abnormal case: physical channel failure during transition from CELL_DCH to CELL_FACH

If the UE fails to select the cell, which was assigned in the RADIO BEARER RECONFIGURATION message initiating transition from CELL_DCH to CELL_FACH, the UE shall make cell reselection to another cell and initiate the cell update procedure.

8.2.2.12 Abnormal case: Suspension of signalling bearer

If the RADIO BEARER RECONFIGURATION message includes a request to suspend the signalling link with the "RB

suspend/resume" IE, the UE shall not suspend uplink transmission on that bearer and it shall send a RADIO BEARER RECONFIGURATION FAILURE message to the UTRAN.

8.2.3 Radio bearer release

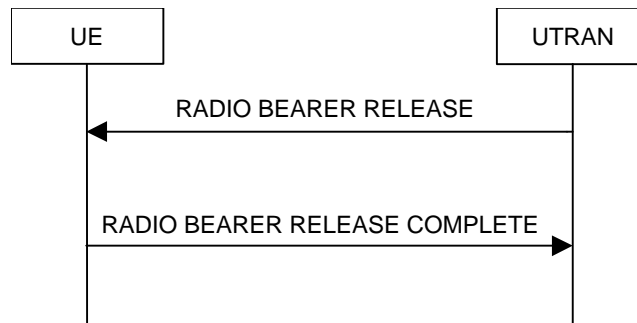

Figure 2421. Radio Bearer Release, normal case

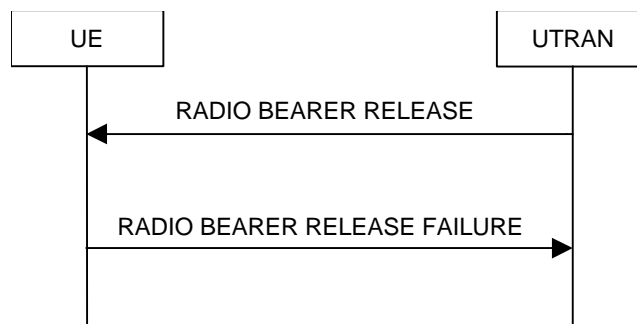

Figure 2522. Radio Bearer Release, UE reverts to old configuration

8.2.3.1 Purpose

The purpose with this procedure is to release existing radio bearer(s).

8.2.3.2 Initiation

The upper layer in the network may request a release of radio bearer(s).

UTRAN shall transmit a RADIO BEARER RELEASE message on the downlink DCCH using AM or UM RLC, and start timer T354.

8.2.3.2.1 Message RADIO BEARER RELEASE contents to set

If transport channels are added, reconfigured or deleted in uplink and/or downlink, UTRAN shall

- Set TFCS according to the new transport channel(s)

If activation time is used this time shall not be set to a larger value than T354.

UTRAN should take the UE capabilities into account when setting the new configuration.

[Editor's note: Other IEs are included and set according to selection by the UTRAN.]

If the message is used to initiate a transition from CELL_DCH to CELL_FACH state, the UTRAN may assign a common channel configuration of a given cell and c-RNTI to be used in that cell to the UE.

8.2.3.3 Reception of RADIO BEARER RELEASE by the UE

Upon reception of a RADIO BEARER RELEASE message the UE shall perform actions according to subclause 8.2.3.3.1 and transmit a RADIO BEARER RELEASE COMPLETE message on the uplink DCCH using AM RLC. When the transmission of the RADIO BEARER RELEASE COMPLETE message has been confirmed by RLC the procedure ends.

If the RADIO BEARER RELEASE message is used to initiate a transition from CELL_DCH to CELL_FACH state, the RADIO BEARER RELEASE COMPLETE message shall be transmitted on the RACH after the UE has completed the state transition.

8.2.3.3.1 Message RADIO BEARER RELEASE contents to use

The UE shall

- For the released radio bearer(s), delete all stored multiplexing options
- For all remaining radio bearer(s), use the multiplexing option applicable for the transport channels used according to their IE RB mapping info'or their previously stored multiplexing options.
- Configure MAC multiplexing if that is needed in order to use said transport channel(s).
- Use MAC logical channel priority when selecting TFC in MAC.

If the IE C-RNTI is included, the UE shall

- Use that C-RNTI when using common transport channels of type RACH, FACH and CPCH in the current cell.

If neither the IEs PRACH info'hor Uplink DPCH info'is included, the UE shall

- Let the physical channel of type PRACH that is given in system information be the default in uplink and enter the CELL_FACH state.

If neither the IEs Secondary CCPCH info'hor Downlink DPCH info'is included, the UE shall

- Start to receive the physical channel of type Secondary CCPCH that is given in system information.

The UE shall use the transport channel(s) applicable for the physical channel types that is used. If neither the IE TFS'is included or previously stored in the UE for that transport channel(s), the UE shall

- Use the TFS given in system information

If none of the TFS stored is compatible with the physical channel, the UE shall

- Delete stored TFS and use the TFS given in system information
- If the RADIO BEARER RELEASE message is used to initiate a state transition to the CELL_FACH state and if an IE primary CCPCH info and C-RNTI to a given cell is included, the UE shallSelect the cell indicated by the PCCPCH info IE.
- Use the C-RNTI when using common transport channels of type RACH, FACH and CPCH in that given cell after having completed the transition to that cell.

Actions that shall be performed by the UE, for other IEs are specified in subclause 8.5.7

8.2.3.3.2 Message RADIO BEARER RELEASE COMPLETE contents to set

FFS

8.2.3.4 Abnormal case: Unsupported configuration in the UE

If UTRAN instructs the UE to use a configuration that it does not support, the UE shall

- Transmit a RADIO BEARER RELEASE FAILURE message on the DCCH using AM RLC.

8.2.3.4.1 Message RADIO BEARER RELEASE FAILURE contents to set

The UE shall set the cause value in IE failure cause'to 'configuration unacceptable'.

8.2.3.5 Abnormal cases: Physical channel failure

If the UE failed to establish the physical channel(s) indicated in the message RADIO BEARER RELEASE the UE shall

- Revert to the configuration prior to the reception of the RADIO BEARER RELEASE message (old configuration) and transmit a RADIO BEARER RELEASE FAILURE message on the DCCH using AM RLC. The procedure ends and the UE resumes the normal operation as if no radio bearer release attempt had occurred.

Criteria to be fulfilled for having a physical channel established are described in subclause 8.5.4

If the UE is unable to revert to the old configuration or if used, the activation time has expired, the UE shall

- Initiate a RRC connection re-establishment procedure according to subclause 8.1.5

8.2.3.5.1 Message RADIO BEARER RELEASE FAILURE contents to set

The UE shall set the cause value in IE failure cause to "physical channel failure"

8.2.3.6 Reception of RADIO BEARER RELEASE COMPLETE by the UTRAN

When UTRAN has received the RADIO BEARER RELEASE COMPLETE message, UTRAN may delete any old configuration. Timer T354 is stopped and the procedure ends on the UTRAN side.

8.2.3.7 Reception of RADIO BEARER RELEASE FAILURE by the UTRAN

When UTRAN has received the RADIO BEARER RELEASE FAILURE message, UTRAN may delete the new configuration. Timer T354 is stopped and the procedure ends on the UTRAN side. Upper layers should be notified of the failure.

8.2.3.8 Abnormal case: T354 timeout

Upon expiry of timer T354 and no RADIO BEARER RELEASE COMPLETE or RADIO BEARER RELEASE FAILURE message has been received, the UTRAN may delete the old and new configuration. All UE dedicated resources may then be cleared, unless the UE requests a re-establishment of the RRC connection.

During transition from CELL_DCH to CELL_FACH, the UTRAN may also receive an CELL UPDATE message if the UE cannot use the assigned physical channel.

8.2.3.9 Abnormal case: physical channel failure during transition from CELL_DCH to CELL_FACH

If the UE fails to select the cell, which was assigned in the RADIO BEARER RELEASE message initiating transition from CELL_DCH to CELL_FACH, the UE shall make cell reselection to another cell and initiate the cell update procedure.

8.2.4 Transport channel reconfiguration

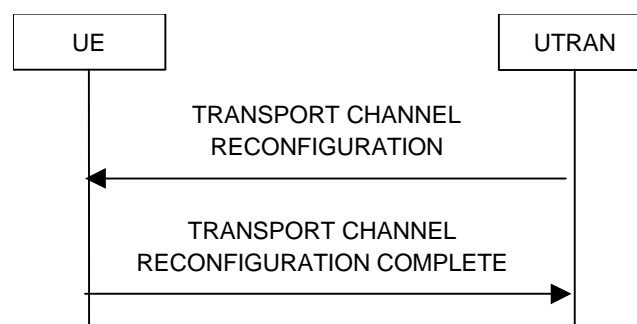

Figure 2623. Transport channel reconfiguration, normal flow

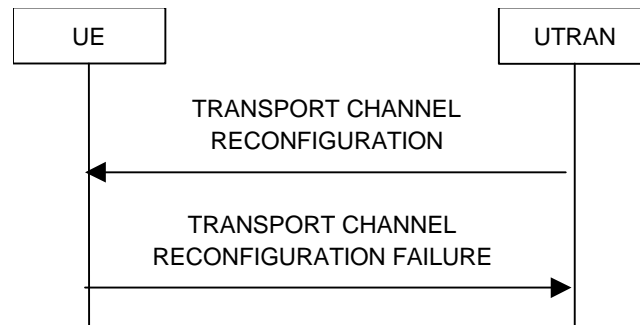

Figure 2724. Transport channel reconfiguration, failure case

8.2.4.1 General

The transport channel reconfiguration procedure is used to reconfigure transport channel parameters.

8.2.4.2 Initiation

The UTRAN shall transmit a TRANSPORT CHANNEL RECONFIGURATION message on the downlink DCCH using AM or UM RLC, and start timer T356.

8.2.4.2.1 Message TRANSPORT CHANNEL RECONFIGURATION contents to set

If transport channels are added, reconfigured or deleted in uplink and/or downlink, the UTRAN shall

- Set TFCS according to the new transport channel(s)

If activation time is used this time shall not be set to a larger value than T356.

UTRAN should take the UE capabilities into account when setting the new configuration.

[Editor's note: Other IEs are included and set according to selection by the UTRAN.] If the message is used to initiate a transition from CELL_DCH to CELL_FACH state, the UTRAN may assign a common channel configuration of a given cell and c-RNTI to be used in that cell to the UE.

8.2.4.3 Reception of TRANSPORT CHANNEL RECONFIGURATION by the UE in CELL_DCH state

Upon reception of a TRANSPORT CHANNEL RECONFIGURATION message in CELL_DCH state, the UE shall perform actions according to subclause 8.2.4.3.1 and transmit a TRANSPORT CHANNEL RECONFIGURATION COMPLETE message on the uplink DCCH using AM RLC. When the transmission of the TRANSPORT CHANNEL RECONFIGURATION COMPLETE message has been confirmed by RLC, the procedure ends.

If the TRANSPORT CHANNEL RECONFIGURATION message is used to initiate a transition from CELL_DCH to CELL_FACH state, the TRANSPORT CHANNEL RECONFIGURATION COMPLETE message shall be transmitted on the RACH after the UE has completed the state transition.

8.2.4.3.1 Message TRANSPORT CHANNEL RECONFIGURATION contents to use in CELL_DCH state

If neither the IEs PRACH info nor Uplink DPCH info is included, the UE shall

- Let the physical channel of type PRACH that is given in system information be the default in uplink and enter the CELL_FACH state.

If neither the IEs Secondary CCPCH info nor Downlink DPCH info is included, the UE shall

- Start to receive the physical channel of type Secondary CCPCH that is given in system information.

The UE shall use the transport channel(s) applicable for the physical channel types that is used. If neither the IE TFS is included or previously stored in the UE for that transport channel(s), the UE shall

- Use the TFS given in system information

If none of the TFS stored is compatible with the physical channel, the UE shall

- Delete stored TFS and use the TFS given in system information

Actions that shall be performed by the UE, for other IEs are specified in subclause 8.5.7

If the TRANSPORT CHANNEL RECONFIGURATION message is used to initiate a state transition to the CELL_FACH state and if an IE primary CCPCH info and C-RNTI to a given cell is included, the UE shall

- Select the cell indicated by the PCCPCH info IE.
- Use the C-RNTI when using common transport channels of type RACH, FACH and CPCH in that given cell after having completed the transition to that cell.

8.2.4.3.2 Message TRANSPORT CHANNEL RECONFIGURATION COMPLETE contents to set in CELL_DCH state

FFS.

8.2.4.4 Reception of TRANSPORT CHANNEL RECONFIGURATION by the UE in CELL_FACH state

Upon reception of a TRANSPORT CHANNEL RECONFIGURATION message in CELL_FACH state, the UE shall perform actions according to subclause 8.2.4.4.1 and transmit a TRANSPORT CHANNEL RECONFIGURATION COMPLETE message on the uplink DCCH using AM RLC. When the transmission of the TRANSPORT CHANNEL RECONFIGURATION COMPLETE message has been confirmed by RLC, the procedure ends.

8.2.4.4.1 Message TRANSPORT CHANNEL RECONFIGURATION contents to use in CELL_FACH state

If the IE C-RNTI is included, the UE shall

- Use that C-RNTI when using common transport channels of type RACH, FACH and CPCH in the current cell.

If neither the IEs PRACH info nor Uplink DPCH info is included, the UE shall

- Let the physical channel of type PRACH that is given in system information be the default in uplink

If neither the IEs Secondary CCPCH info nor Downlink DPCH info is included, the UE shall

- Start to receive the physical channel of type Secondary CCPCH that is given in system information.

The UE shall use the transport channel(s) applicable for the physical channel types that is used. If neither the IE TFS is included or previously stored in the UE for that transport channel(s), the UE shall

- Use the TFS given in system information

If none of the TFS stored is compatible with the physical channel, the UE shall

- Delete stored TFS and use the TFS given in system information

Actions that shall be performed by the UE, for other IEs are specified in subclause 8.5.7

8.2.4.4.2 Message TRANSPORT CHANNEL RECONFIGURATION COMPLETE contents to set in CELL_FACH state

FFS.

8.2.4.5 Reception of TRANSPORT CHANNEL RECONFIGURATION COMPLETE by the UTRAN

When UTRAN has received the TRANSPORT CHANNEL RECONFIGURATION COMPLETE message, UTRAN may delete any old configuration. Timer T356 is stopped and the procedure ends on the UTRAN side.

UTRAN may delete the C-RNTI of the UE if the procedure caused the UE to leave the CELL_FACH state.

8.2.4.6 Abnormal case: Unsupported configuration in the UE

If the UE instructs the UE to use a configuration which it does not support, the UE shall

- transmit a TRANSPORT CHANNEL RECONFIGURATION FAILURE message on the DCCH using AM RLC.

8.2.4.6.1 Message TRANSPORT CHANNEL RECONFIGURATION FAILURE contents to set

The UE shall set the cause value in IE "failure cause" to "configuration unacceptable".

8.2.4.7 Abnormal case: Physical channel failure

If the UE failed to establish the physical channel(s) indicated in the message TRANSPORT CHANNEL RECONFIGURATION the UE shall

- Revert to the configuration prior to the reception of the TRANSPORT CHANNEL RECONFIGURATION message (old configuration) and transmit a TRANSPORT CHANNEL RECONFIGURATION FAILURE message on the DCCH using AM RLC. The procedure ends and the UE resumes the normal operation as if no transport channel reconfiguration attempt had occurred.

Criteria to be fulfilled for having a physical channel established are described in subclause 8.5.4

If the UE is unable to revert to the old configuration or if used, the activation time has expired, the UE shall

- Initiate a RRC connection re-establishment procedure according to subclause 8.1.5

8.2.4.7.1 Message TRANSPORT CHANNEL RECONFIGURATION FAILURE contents to set

The UE shall set the cause value in IE "failure cause" to "physical channel failure".

8.2.4.8 Reception of TRANSPORT CHANNEL RECONFIGURATION FAILURE by the UTRAN

When UTRAN has received the RADIO BEARER RECONFIGURATION FAILURE message, UTRAN may delete the new configuration. Timer T356 is stopped and the procedure ends on the UTRAN side. Upper layers should be notified of the failure.

8.2.4.9 Abnormal case: T356 timeout in CELL_DCH state

Upon expiry of timer T356 and no TRANSPORT CHANNEL RECONFIGURATION COMPLETE or TRANSPORT CHANNEL RECONFIGURATION FAILURE message has been received, the UTRAN may delete the old and new configuration. If the UE requests a re-establishment of the RRC connection, before all UE dedicated resources have been cleared, the new configuration may be re-assigned in the re-establishment procedure.

During transition from CELL_DCH to CELL_FACH, the UTRAN may also receive an CELL UPDATE message if the UE cannot use the assigned physical channel.

8.2.4.10 Abnormal case: T356 timeout in CELL_FACH state

Upon expiry of timer T356 and no TRANSPORT CHANNEL RECONFIGURATION COMPLETE or TRANSPORT CHANNEL RECONFIGURATION FAILURE message has been received, the UTRAN may delete the old and new configuration. If the UE makes a cell update before all UE dedicated resources have been cleared, the configuration procedure can be restarted.

8.2.4.11 Abnormal case: physical channel failure during transition from CELL_DCH to CELL_FACH

If the UE fails to select the cell, which was assigned in the XXX message initiating transition from CELL_DCH to CELL_FACH, the UE shall make cell reselection to another cell and initiate the cell update procedure.

8.2.5 Transport format combination control

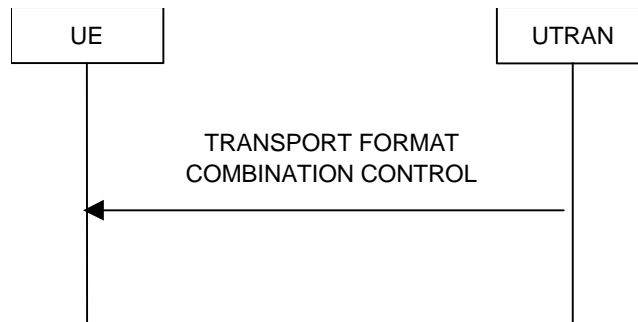

Figure 2825. Transport format combination control, normal flow

8.2.5.1 General

The transport format combination control procedure is used to control the allowed uplink transport format combinations within the transport format combination set.

8.2.5.2 Initiation

The UTRAN shall transmit the TRANSPORT FORMAT COMBINATION CONTROL message on the downlink DCCH using AM or UM RLC.

8.2.5.2.1 Message TRANSPORT CHANNEL COMBINATION CONTROL contents to set

To restrict allowed transport format combinations, the UTRAN shall set the allowed TFCs in the "TFC subset" IE.

To remove previous restrictions of allowed transport format combination, the UTRAN shall set "full transport format combination set" in the "TFC subset" IE.

8.2.5.3 Reception of TRANSPORT CHANNEL COMBINATION CONTROL by the UE

Upon reception of the TRANSPORT CHANNEL COMBINATION CONTROL message, the UE shall configure the allowed transport format combinations as defined in subclause 8.5.7.5.3

8.2.6 Physical channel reconfiguration

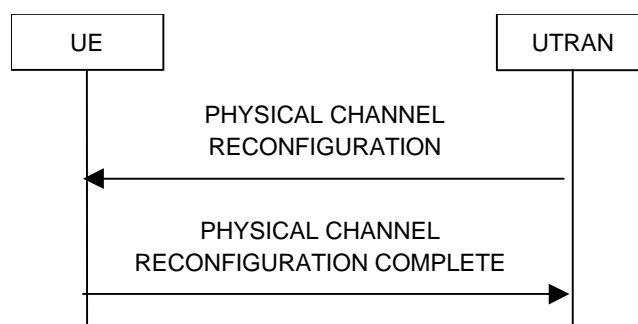

Figure 2926. Physical channel reconfiguration, normal flow

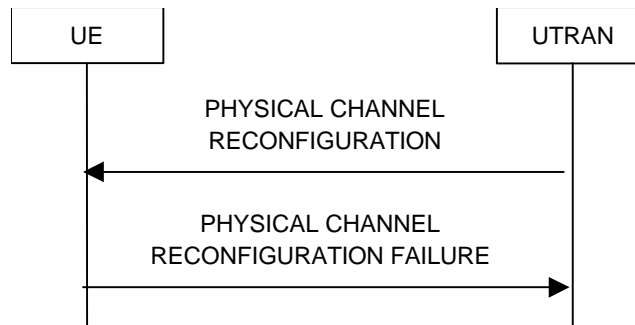

Figure 3027. Physical channel reconfiguration, failure case

8.2.6.1 General

The physical channel reconfiguration procedure is used to establish, reconfigure and release physical channels.

8.2.6.2 Initiation

The UTRAN shall transmit a PHYSICAL CHANNEL RECONFIGURATION message on the downlink DCCH using AM or UM RLC, and start timer T357.

8.2.6.2.1 Message PHYSICAL CHANNEL RECONFIGURATION contents to set

If activation time is used this time shall not be set to a larger value than T357.

UTRAN should take the UE capabilities into account when setting the new configuration.

[Editor's note: Other IEs are included and set according to selection by the UTRAN.]

If the message is used to initiate a transition from CELL_DCH to CELL_FACH state, the UTRAN may assign a common channel configuration of a given cell and c-RNTI to be used in that cell to the UE.

8.2.6.3 Reception of PHYSICAL CHANNEL RECONFIGURATION by the UE in CELL_DCH state

Upon reception of a PHYSICAL CHANNEL RECONFIGURATION message, the UE shall perform actions according to subclause 8.2.6.3.1 and transmit a PHYSICAL CHANNEL RECONFIGURATION COMPLETE message on the uplink DCCH using AM RLC. When the transmission of the PHYSICAL CHANNEL RECONFIGURATION COMPLETE message has been confirmed by RLC, the procedure ends.

If the PHYSICAL CHANNEL RECONFIGURATION message is used to initiate a transition from CELL_DCH to CELL_FACH state, the PHYSICAL CHANNEL RECONFIGURATION COMPLETE message shall be transmitted on the RACH after the UE has completed the state transition.

8.2.6.3.1 Message PHYSICAL CHANNEL RECONFIGURATION contents to use in CELL_DCH state

If the IE C-RNTI is included, the UE shall

- Use that C-RNTI when using common physical channels of type RACH, FACH and CPCH in the current cell.

If neither the IEs PRACH info nor Uplink DPCH info is included, the UE shall

- Let the physical channel of type PRACH that is given in system information be the default in uplink and enter the CELL_FACH state.

If neither the IEs Secondary CCPCH info nor Downlink DPCH info is included, the UE shall

- Start to receive the physical channel of type Secondary CCPCH that is given in system information.

The UE shall use the physical channel(s) applicable for the physical channel types that is used. If neither the IE TFS'is included or previously stored in the UE for that physical channel(s), the UE shall

- Use the TFS given in system information

If none of the TFS stored is compatible with the physical channel, the UE shall

- Delete stored TFS and use the TFS given in system information

Actions that shall be performed by the UE, for other IEs are specified in subclause 8.5.7

If the PHYSICAL CHANNEL RECONFIGURATION message is used to initiate a state transition to the CELL_FACH state and if an IE primary CCPCH info and C-RNTI to a given cell is included, the UE shall

- Select the cell indicated by the PCCPCH info IE.
- Use the C-RNTI when using common transport channels of type RACH, FACH and CPCH in that given cell after having completed the transition to that cell.

8.2.6.4 Reception of PHYSICAL CHANNEL RECONFIGURATION by the UE in CELL_FACH state

Upon reception of a PHYSICAL CHANNEL RECONFIGURATION message, the UE shall read the IE DRX indicator' If the IE DRX indicator'is set to DRX with Cell updating,'the UE shall

- Perform actions according to subclause 8.2.6.4.1
- Transmit a PHYSICAL CHANNEL RECONFIGURATION COMPLETE message on the uplink DCCH using AM RLC
- When the transmission of the PHYSICAL CHANNEL RECONFIGURATION COMPLETE message has been confirmed by RLC, the UE shall delete its C-RNTI, move to Cell_PCH state and start updating its location on the URA level. This ends the procedure.

If the IE DRX indicator'is set to DRX with URA updating,'the UE shall

- Perform actions according to 8.2.6.4.1
- Transmit a PHYSICAL CHANNEL RECONFIGURATION COMPLETE message on the uplink DCCH using AM RLC
- When the transmission of the PHYSICAL CHANNEL RECONFIGURATION COMPLETE message has been confirmed by RLC, the UE shall delete its C-RNTI, move to URA_PCH and start updating its location on the URA level. This ends the procedure.

If the IE DRX indicator'is set to DRX with URA updating,'the UE shall

- Perform actions according to subclause 8.2.6.4.1 and transmit a PHYSICAL CHANNEL RECONFIGURATION COMPLETE message on the uplink DCCH using AM RLC. When the transmission of the PHYSICAL CHANNEL RECONFIGURATION COMPLETE message has been confirmed by RLC, the procedure ends.

8.2.6.4.1 Message PHYSICAL CHANNEL RECONFIGURATION contents to use in CELL_FACH state

If the IE C-RNTI is included, the UE shall

- Use that C-RNTI when using common physical channels of type RACH, FACH and CPCH in the current cell.

If neither the IEs PRACH info' nor Uplink DPCH info' is included, the UE shall

- Let the physical channel of type PRACH that is given in system information be the default in uplink and enter the CELL_FACH state.

If neither the IEs Secondary CCPCH info' nor Downlink DPCH info' is included, the UE shall

- Start to receive the physical channel of type Secondary CCPCH that is given in system information.

The UE shall use the physical channel(s) applicable for the physical channel types that is used. If neither the IE TFS'is included or previously stored in the UE for that physical channel(s), the UE shall

- Use the TFS given in system information

If none of the TFS stored is compatible with the physical channel, the UE shall

- Delete stored TFS and use the TFS given in system information

Actions that shall be performed by the UE, for other IEs are specified in subclause 8.5.7

8.2.6.4.2 Message PHYSICAL CHANNEL RECONFIGURATION COMPLETE contents to set FFS.

8.2.6.5 Reception of PHYSICAL CHANNEL RECONFIGURATION COMPLETE by the UTRAN

When UTRAN has received the PHYSICAL CHANNEL RECONFIGURATION COMPLETE message, UTRAN may delete any old configuration. Timer T357 is stopped and the procedure ends on the UTRAN side.

UTRAN may delete the C-RNTI of the UE if the procedure caused the UE to leave the CELL_FACH state.

8.2.6.6 Abnormal case: Unsupported configuration in the UE

If the UE instructs the UE to use a configuration which it does not support, the UE shall

- transmit a PHYSICAL CHANNEL RECONFIGURATION FAILURE message on the DCCH using AM RLC.

8.2.6.6.1 Message PHYSICAL CHANNEL RECONFIGURATION FAILURE contents to set

The UE shall set the cause value in IE "failure cause" to "configuration unacceptable".

8.2.6.7 Abnormal case: Physical channel failure

If the UE failed to establish the physical channel(s) indicated in the message PHYSICAL CHANNEL RECONFIGURATION the UE shall

- Revert to the configuration prior to the reception of the PHYSICAL CHANNEL RECONFIGURATION message (old configuration) and transmit a PHYSICAL CHANNEL RECONFIGURATION FAILURE message on the DCCH using AM RLC. The procedure ends and the UE resumes the normal operation as if no physical channel reconfiguration attempt had occurred.

Criteria to be fulfilled for having a physical channel established are described in subclause 8.5.4

If the UE is unable to revert to the old configuration or if used, the activation time has expired, the UE shall

- Initiate a RRC connection re-establishment procedure according to subclause 8.1.5

8.2.6.7.1 Message PHYSICAL CHANNEL RECONFIGURATION FAILURE contents to set

The UE shall set the cause value in IE "failure cause" to "physical channel failure".

8.2.6.8 Reception of PHYSICAL CHANNEL RECONFIGURATION FAILURE by the UTRAN

When UTRAN has received the RADIO BEARER RECONFIGURATION FAILURE message, UTRAN may delete the new configuration. Timer T357 is stopped and the procedure ends on the UTRAN side. Upper layers should be notified of the failure.

8.2.6.9 Abnormal case: T357 timeout in CELL_DCH state

Upon expiry of timer T357 and no PHYSICAL CHANNEL RECONFIGURATION COMPLETE or PHYSICAL CHANNEL RECONFIGURATION FAILURE message has been received, the UTRAN may delete the old and new configuration. If the UE requests a re-establishment of the RRC connection, before all UE dedicated resources have been cleared, the new configuration may be re-assigned in the re-establishment procedure.

During transition from CELL_DCH to CELL_FACH, the UTRAN may also receive an CELL UPDATE message if the UE cannot use the assigned physical channel.

8.2.6.10 Abnormal case: T357 timeout in CELL_FACH state

Upon expiry of timer T357 and no PHYSICAL CHANNEL RECONFIGURATION COMPLETE or PHYSICAL CHANNEL RECONFIGURATION FAILURE message has been received, the UTRAN may delete the old and new configuration. If the UE makes a cell update before all UE dedicated resources have been cleared, the configuration procedure can be restarted.

8.2.6.11 Abnormal case: physical channel failure during transition from CELL_DCH to CELL_FACH

If the UE fails to select the cell, which was assigned in the XXX message initiating transition from CELL_DCH to CELL_FACH, the UE shall make cell reselection to another cell and initiate the cell update procedure.

8.2.7 Physical Shared Channel Allocation [TDD only]



Figure 3128: Physical Shared Channel Allocation

8.2.7.1 General

The purpose of this procedure is to allocate physical resources to USCH or DSCH transport channels in TDD mode, for temporary usage by a UE.

8.2.7.2 Initiation

Precondition: The UE is in the CELL_FACH or CELL_DCH state, and at least one RAB using USCH or DSCH has been established.

Triggering event: The RRC in the CRNC is aware that the UE needs capacity for USCH and/or DSCH has decided to allocate physical resources to the respective shared channel.

Action taken: The RRC in the C-RNC sends the message 'Physical Shared Channel Reconfiguration' in the SHCCH over the FACH, to allocate PUSCH or PDSCH resources to exactly one CCTrCH.

8.2.7.2.1 Message PHYSICAL SHARED CHANNEL ALLOCATION contents to set

The C-RNTI is used to address the UE.

If Physical Channels (PUSCH or PDSCH) shall be allocated, the message shall include the parameters PUSCH Allocation pending, TFCS- ID, CCTrCH Activation CFN, CCTrCH Duration, the PUSCH or PDSCH Information, and an optional Timing Advance information.

Note: The message can also be used to block or enable the UE to issue PUSCH capacity requests, without allocating PUSCH or PDSCH, as shown in the PUSCH CAPACITY REQUEST procedure below. In this case, no TFCS-ID and no PUSCH or PDSCH Information is included.

- The TFCS-ID specifies the CCTrCH for which Physical Channels (PUSCH or PDSCH) are allocated.

- CcTrCH Activation CFN shall be the frame number at which the physical channels are available to that CcTrCH.
- CcTrCH Duration shall specify the number of frames for which the physical channels are available.

If the message is used to allocate resources to a CcTrCH that carries DSCH channels, the message shall include PDSCH Information for the respective PDSCH channels.

If the message is used to allocate resources to a CcTrCH that carries USCH channels, the message shall include PUSCH Information for the respective PUSCH channels.

Whenever PUSCH resources for Uplink transmission are allocated in the message, the optional Timing Advance" parameter may be added.

In any case the message shall include the parameter PUSCH allocation pending" which assumes the values pending" or not pending". PUSCH allocation pending" has the effect of blocking the UE for some time to issue PUSCH capacity requests on the RACH.

8.2.7.3 Reception of PHYSICAL SHARED CHANNEL ALLOCATION by the UE

The UE shall check the C-RNTI to see if the UE is addressed by the message. If so, the UE shall evaluate the message and use the IEs as specified below.

8.2.7.3.1 Message PHYSICAL SHARED CHANNEL ALLOCATION contents to use

If the CcTrCH addressed in the message is a CcTrCH for DSCH, the UE shall:

- decode the IEs CcTrCH Activation CFN" and CcTrCH Duration," to determine the time interval for which the allocation shall be valid;
- configure Layer 1 according to the PDSCH information, for the specified time interval;
- start receiving the PDSCH where the TFCI is included;
- receive the PDSCHs, and decode and demultiplex them into the respective DSCH channels according to the TFCI.

If the CcTrCH addressed in the message is a CcTrCH for USCH, the UE shall:

- decode the IEs CcTrCH Activation CFN" and CcTrCH Duration," to determine the time interval for which the allocation shall be valid;
- configure Layer 1 according to the PUSCH information, for the specified time interval;
- evaluate and apply the potential Timing Advance value for uplink transmissions;
- determine the TFCS subset and hence the TFCI values which are possible given the PUSCH allocation for that CcTrCH;
- configure the MAC-sh in the UE with this TFCS restriction if necessary;
- transmit USCH Transport Block Sets as required, within the TFCS limits given by the PUSCH allocation.

In addition, the UE shall evaluate the PUSCH Allocation Pending" parameter: If its value is pending," the UE starts a timer T311. As long as this timer is running, the UE is not allowed to use the RACH for potential USCH capacity requests. See the USCH CAPACITY REQUEST procedure.

8.2.8 PUSCH capacity request [TDD only]

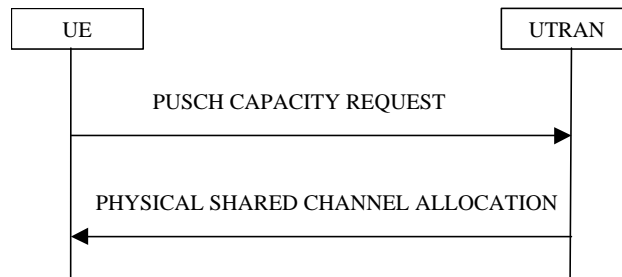

Figure 3229. PUSCH Capacity request procedure

8.2.8.1 General

With this procedure, the UE transmits its request for PUSCH resources to the UTRAN. In the normal case, the UTRAN responds with a Physical Shared Channel Allocation, which either allocates the requested PUSCH resources, or allocates a PDSCH resource, or may just serve as an acknowledgement, indicating that PUSCH allocation is pending.

With the message PUSCH CAPACITY REQUEST, the UE can request capacity for one or more USCH.

<Note: Triggering of the capacity request is controlled by the measurement control procedure. It is FFS whether a measurement report message can be used instead of the PUSCH capacity request message.>

8.2.8.2 Initiation

The UE is in the CELL_FACH or CELL_DCH state, and at least one RAB using USCH has been established. The RRC in the UE sees the requirement to allocate physical resources (PUSCH) to an USCH channel.

The RRC decides to send a PUSCH capacity request on the RACH. This is possible if

- No USCH transmission takes place, where the capacity request for further PUSCH resources could be included, and
- The UE has been informed by the UTRAN that no PUSCH allocation is pending –or the timer T311 has been expired.
- The timer T310 (capacity request repetition timer) is not running.

So the UE sends a PUSCH CAPACITY REQUEST message on the uplink SHCCH on the RACH, resets counter V310, and starts timer T310.

8.2.8.2.1 Message PUSCH CAPACITY REQUEST contents to set

With one PUSCH CAPACITY REQUEST message, capacity for one or more USCH can be requested. It shall include these information elements:

- C-RNTI to be used as UE identity.
- Radio Bearer ID, for each radio bearer requiring capacity on USCH.
- RLC buffer payload for these radio bearers

As an option, the message may include:

- Intra-frequency measurement report

The object to be measured shall have been configured before. A typical example is the interference in a DL Time Slot.

8.2.8.3 Reception of PUSCH CAPACITY REQUEST by the UTRAN

Once the RRC in C-RNC receives the PUSCH CAPACITY REQUEST, it shall send a PHYSICAL SHARED CHANNEL ALLOCATION message to the UE, either for allocating PUSCH or PDSCH resources, or just as an

acknowledgement, announcing a pending PUSCH allocation.

8.2.8.3.1 Message PHYSICAL SHARED CHANNEL ALLOCATION contents to set

The contents of that message is the same as in the Physical Shared Channel Allocation procedure. It may or may not contain PUSCH channels to allocate. However it shall include the parameter PUSCH Allocation Pending. If this is set to pending, the UE is temporarily inhibited to send any further PUSCH capacity requests on the RACH.

8.2.8.4 Reception of PHYSICAL SHARED CHANNEL ALLOCATION by the UE

Once the UE receives this message with the correct C-RNTI included, it shall stop the timer T310 and shall evaluate the message.

8.2.8.4.1 Message PHYSICAL SHARED CHANNEL ALLOCATION contents to use

The UE shall evaluate the message as described in the Physical Shared Channel Allocation procedure. In particular, it shall take the parameter PUSCH Allocation Pending into account: If this parameter has the value pending, the UE shall start the timer T311. As long as this timer is running, the UE is prohibited to send PUSCH Capacity Requests on the SHCCH via the RACH.

If the parameter PUSCH Allocation Pending indicates not pending, the UE shall stop the timer T311, and is allowed to send PUSCH Capacity Requests on the RACH again.

If the PUSCH capacity allocated in this message is not sufficient for all the USCH transmission requests which the UE may have, the RRC in the UE may decide to issue further PUSCH Capacity Requests, either on the USCH or on the RACH provided the RACH is available, i.e. timer T311 is not running..

8.2.8.5 Abnormal case: T310 time out

Upon expiry of timer T310, the UE shall

- If V310 is smaller or equal than N310, transmit a new PUSCH CAPACITY REQUEST on the Uplink SHCCH, restart timer T310 and increase counter V310. The UE shall set the IEs in the PUSCH CAPACITY REQUEST message as specified above.

8.2.8.6 Abnormal case: Maximum number of re-attempts exceeded

In this case the UE stops the procedure. It can start another PUSCH CAPACITY REQUEST procedure if the UE-RRC sees the need for it.

8.2.9 Downlink power control

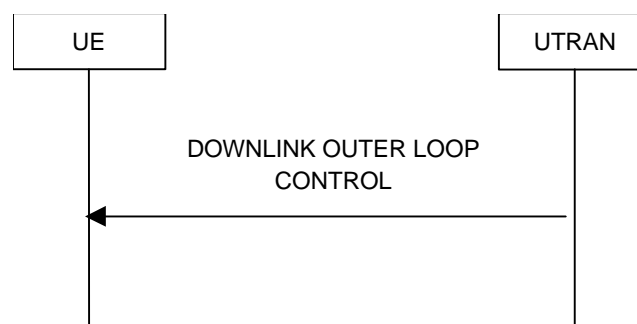

Figure 3330) Downlink Outer Loop Control , normal flow

8.2.9.1 General

The downlink outer loop control procedure is used to control the downlink outer loop power control running in the UE.

8.2.9.2 Initiation

The UTRAN shall transmit the DOWNLINK OUTER LOOP CONTROL message on the downlink DCCH using AM or UM RLC.

8.2.9.2.1 Message DOWNLINK OUTER LOOP CONTROL contents to set

To prevent the UE from increasing its DL Eb/No target value above its current value, the UTRAN shall set the Downlink Outer Loop Control'IE to TRUE.

To remove the previous restriction on the downlink outer loop power control, the UTRAN shall set the Downlink Outer

8.2.9.3 Reception of DOWNLINK OUTER LOOP CONTROL by the UE

Upon reception of the DOWNLINK OUTER LOOP CONTROL message, the UE shall read the Downlink Outer Loop

8.2.9.3.1 Message DOWNLINK OUTER LOOP CONTROL contents to use

If the Downlink Outer Loop Control'IE is set to TRUE, the UE shall prevent its DL Eb/No target value from increasing above the current value.

If the Downlink Outer Loop Control'IE is set to FALSE, the UE shall remove the above restriction.

8.3 RRC connection mobility procedures

8.3.1 Cell update

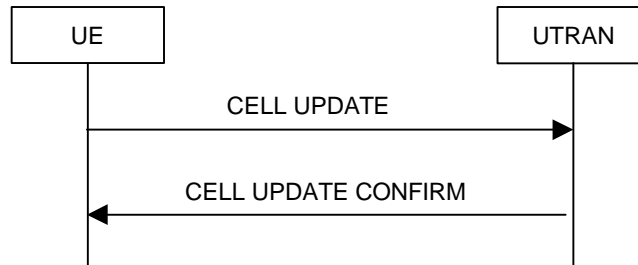

Figure 3431. Cell update procedure, basic flow

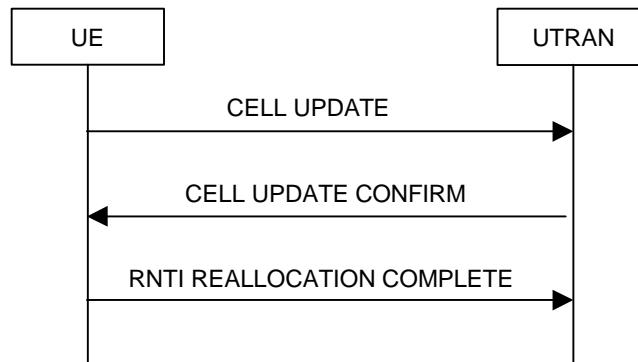

Figure 3532. Cell update procedure with RNTI reallocation

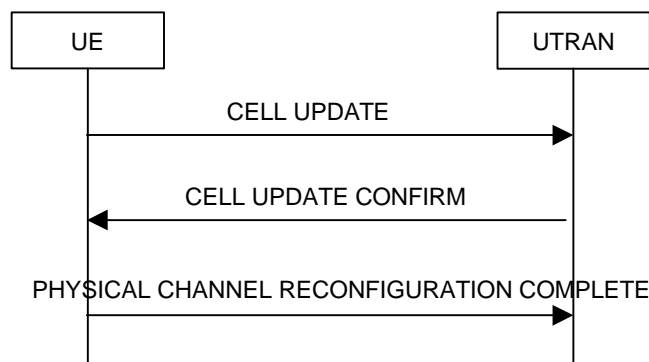

Figure 3633. Cell update procedure with physical channel reconfiguration

8.3.1.1 General

The main purpose of the cell update procedure is to update UTRAN with the current cell of the UE after cell reselection in CELL_FACH or CELL_PCH state. It may also be used for supervision of the RRC connection, even if no cell reselection takes place. The cell update procedure can also be used to re-configure the c-plane AM_RLC. UE can use CELL UPDATE message to notify the unrecoverable error in AM_RLC on c-plane [Note 1].

[Editor's note: Physical channel reconfiguration complete is only used when common channels are configured (doesn't apply to dedicated channels)]

8.3.1.2 Initiation

8.3.1.2.1 Cell update due to cell reselection

When the UE is in CELL_FACH or CELL_PCH state and originates from an UTRA cell and makes a successful reselection of another UTRA cell, it shall

- move to CELL_FACH state, if not already in that state
- transmit a CELL UPDATE message on the uplink CCCH,
- start timer T302 and reset counter V302

The IE 'cell update cause' shall be set to 'cell reselection.'

8.3.1.2.2 Cell update due to periodical cell update

When the UE is in CELL_FACH or CELL_PCH state, the UE shall perform periodic cell updating according to the system information. The timer T305 shall be reset when entering CELL_FACH or CELL_PCH state and after the completion of the Cell Update Procedure in CELL_FACH or CELL_PCH state.

Upon expiry of timer T305 and the UE detects that it is in the service area, the UE shall

- move to CELL_FACH state, if not already in that state
- transmit a CELL UPDATE message on the uplink CCCH,
- start timer T302 and reset counter V302

The IE 'Cell update cause' shall be set to 'periodic cell update.'

8.3.1.2.3 Cell update due to UL data transmission

When the UE is in CELL_PCH or URA_PCH state, the UE shall perform cell updating if the UE wants to transmit UL data. The timer T305 shall be reset after the completion of the Cell Update Procedure in CELL_FACH state.

The UE shall

- move to CELL_FACH state, if not already in that state
- transmit a CELL UPDATE message on the uplink CCCH,
- start timer T302 and reset counter V302

The IE 'Cell update cause' shall be set to 'UL data transmission.'

8.3.1.2.4 Cell update due to paging response

When the UE is in CELL_PCH and URA_PCH state, the UE shall perform a cell update procedure, when receiving a PAGING TYPE 1 message as in subclause 8.1.2.3 The timer T305 shall be reset after the completion of the Cell Update Procedure in CELL_FACH state.

The UE shall

- move to CELL_FACH state
- transmit a CELL UPDATE message on the uplink CCCH,
- start timer T302 and reset counter V302

The IE 'Cell update cause' shall be set to 'paging response.'

8.3.1.3 Abnormal cases: T305 expiry and the UE detects that it is out of service area

When the T305 expires and the UE detects that it is out of service area which is specified in subclause 8.5.5, the UE shall

- start timer T307
- search for cell to camp

8.3.1.3.1 Re-entering of service area

When the UE detects that it is no longer out of service area before the expiry of T307, the UE shall

- transmit Cell Update message on the uplink CCCH

8.3.1.3.2 Expiry of timer T307

- When the T307 expires, the UE shall move to idle mode. UE shall release all dedicated resources and a connection failure may be indicated to the non-access stratum. Other actions the UE shall perform when entering idle mode from connected mode are specified in subclause 8.5.2

8.3.1.3.3 Message CELL UPDATE contents to set

The IE Cell update cause shall be set to the event causing the transmission of the CELL UPDATE message, see subclauses 8.3.1.2.1, 8.3.1.2.2, 8.3.1.2.3 and 8.3.1.2.4.

The IE AM_RLC error indication shall be set when the UE detects unrecoverable error in AM_RLC error on c-plane.

The UE shall include an intra-frequency measurement report in the CELL UPDATE message, when instructed to do so in the system information.

8.3.1.4 Reception of CELL UPDATE by the UTRAN

When the UTRAN receives a CELL UPDATE message, it shall transmit a CELL UPDATE CONFIRM message on the downlink DCCH.

When the UTRAN detects AM_RLC error, it waits for CELL UPDATE message from the UE and when the UTRAN receives it, UTRAN commands the UE to re-configure AM_RLC by sending CELL UPDATE CONFIRM message. This procedure can be used not only in the case of AM_RLC error but also in the case that UTRAN wants to re-configure AM_RLC for other reasons such as in the case when SRNC Relocation is initiated without keeping RLC status (current counters) from old SRNC to new SRNC.

When the UTRAN receives an IE Cell update cause which is set to 'UL data transmission' or 'paging response', the UE and the UTRAN states shall be transit to CELL_FACH state.

When the UTRAN detects the frequent Cell Updating with no data transmission on UL and DL, the UE and the UTRAN states may be transit to URA_PCH state.

8.3.1.4.1 Message CELL UPDATE CONFIRM contents to set

UTRAN shall use the same U-RNTI for the transmission of CELL UPDATE CONFIRM as the values of the IE U-RNTI in the received message CELL UPDATE.

UTRAN may allocate a new C-RNTI and/or a new U-RNTI for the UE. In that case UTRAN shall include those new identities in the IEs 'new C-RNTI', 'new U-RNTI', and start timer T361.

UTRAN may allocate new PRACH and/or Secondary CCPCH for FACH to the UE. In that case UTRAN shall include the IEs 'PRACH info' and/or 'Secondary CCPCH info'. UTRAN shall start timer T357. When the UTRAN receives an IE Cell update cause which is set to 'UL data transmission', the UTRAN shall include these parameters.

UTRAN may set 'DRX indicator' to 'DRX with URA updating' and optionally 'URA Id' when the UTRAN orders the UE to change its state to URA_PCH state.

UTRAN may set "DRX indicator" to "DRX with Cell updating" to order the UE to change its state to Cell_PCH state.

UTRAN may set "DRX indicator" to "No DRX" to order the UE to change its state to Cell_FACH state.

8.3.1.5 Reception of CELL UPDATE CONFIRM by the UE

- When the UE receives a CELL UPDATE CONFIRM message on the downlink DCCH, it shall stop timer T302 and restart timer T305

- Perform the actions stated in subclauses 8.5.7.6.2 and 8.5.7.6.3
- transmit a PHYSICAL CHANNEL RECONFIGURATION COMPLETE message on the uplink DCCH. The procedure ends when the RLC has confirmed the transmission of that message and the UE shall go back to CELL_PCH state and delete its C-RNTI if the cell update procedure was initiated from that state and the IE Cell update cause in CELL UPDATE message was not set to UL data transmission or paging response. The UE shall transit to CELL_FACH state if the IE Cell update cause in CELL UPDATE message was set to UL data transmission or paging response. The UE shall transit to CELL_FACH state if the IE DRX indicator was set to "No

If the CELL UPDATE CONFIRM message includes the IEs PRACH info and/or Secondary CCPCH info, and at least one of the IEs new C-RNTI, or new U-RNTI, the UE shall

- Perform the applicable actions stated in subclause 8.5.7

If the CELL UPDATE CONFIRM message includes the IEs CN domain identity and NAS system information, the UE shall forward the content of the IE to the non-access stratum entity of the UE indicated by the IE CN domain identity.

If the CELL UPDATE CONFIRM message includes neither the IEs PRACH info, Secondary CCPCH info, new C-RNTI, nor new U-RNTI, the procedure ends and the UE shall go back to CELL_PCH state and delete its C-RNTI if the cell update procedure was initiated from that state. The UE shall transit to CELL_FACH state if the IE DRX indicator

8.3.1.6 Abnormal cases: T302 expiry or cell reselection

- Upon expiry of timer T302, and/or
 - upon reselection of another UTRA cell when waiting for the CELL UPDATE CONFIRM message,
- the UE shall check the value of V302 and
- If V302 is smaller or equal than N302, the UE shall retransmit a CELL UPDATE message on the uplink CCCH, restart timer T302 and increase counter V302. The IE Cell update cause shall be set to the event causing the transmission of the CELL UPDATE message, see subclauses 8.3.1.2.1, 8.3.1.2.2, 8.3.1.2.3 and 8.3.1.2.4
 - If V302 is greater than N302, the UE shall enter idle mode. The procedure ends and a connection failure may be indicated to the non-access stratum. Other actions the UE shall perform when entering idle mode from connected mode are specified in subclause 8.5.2

8.3.1.7 Reception of RNTI REALLOCATION COMPLETE by the UTRAN

See subclause 8.3.3.4

8.3.1.8 Reception of PHYSICAL CHANNEL RECONFIGURATION COMPLETE by the UTRAN

FFS

8.3.1.9 Abnormal case: T357 expiry

FFS

8.3.2 URA update

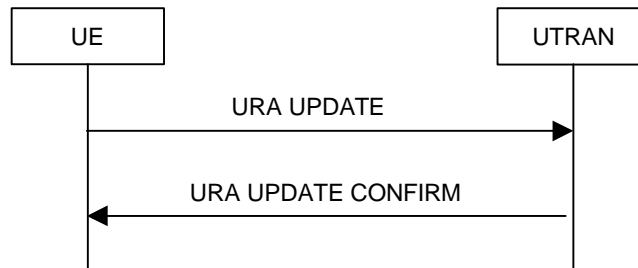

Figure 3734. URA update procedure, basic flow

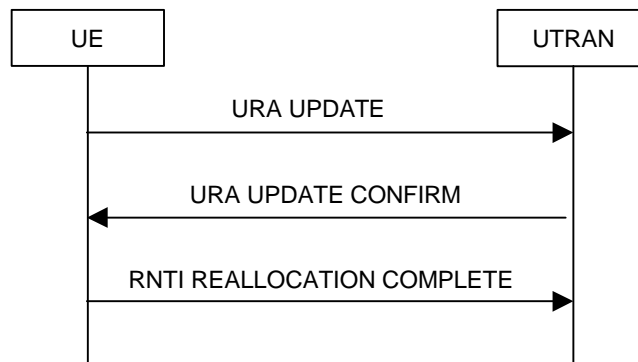

Figure 3835. URA update procedure with RNTI reallocation

8.3.2.1 General

The main purpose of the URA update procedure is to update UTRAN with the current URA of the UE after URA reselection in URA_PCH state. It may also be used for supervision of the RRC connection, even if no URA reselection takes place. UTRAN registration areas may be hierarchical to avoid excessive signalling. This means that several URA identifiers may be broadcast in one cell and that different UEs in one cell may reside in different URAs. A UE in URA_PCH state shall always have one and only one valid URA. The URA UPDATE CONFIRM message may also contain new NAS system information.

8.3.2.2 Initiation

8.3.2.2.1 URA update due to URA reselection

When the UE is in URA_PCH state and the current URA assigned to the UE is not present in the list of URA IDs broadcast in a cell,

, it shall

- temporarily store the list of URA IDs broadcasted in a cell

- move to CELL_FACH state
- transmit a URA UPDATE message on the uplink CCCH,
- start timer T303 and reset counter V303

The IE URA update cause shall be set to URA reselection.

8.3.2.2.2 URA update due to periodical URA update

When the UE is in URA_PCH state, the UE shall perform periodic URA updating according to the system information. The timer T306 shall be reset when entering URA_PCH state and after the completion of the URA Update Procedure.

Upon expiry of timer T306 and the UE detects that it is in the service area, which is specified in subclause 8.5.4, the UE shall

- move to CELL_FACH state
- transmit a URA UPDATE message on the uplink CCCH,
- start timer T303 and reset counter V303

The IE URA update cause shall be set to periodic URA update.

8.3.2.3 Abnormal cases: T306 expiry and the UE detects that it is out of service area

When the T306 expires and the UE detects that it is out of service area, which is specified in subclause 8.5.4, the UE shall

- start timer T307
- search for cell to camp

When the UE detects that it is no longer out of service area before the expiry of T307, the UE shall

- transmit URA Update message on the uplink CCCH

When the T307 expires

- the UE shall move to idle state.

8.3.2.4 Message URA UPDATE contents to set

The IE URA update cause shall be set to the event causing the transmission of the URA UPDATE message, see subclauses 8.3.2.2.1 and 8.3.2.2.2.

8.3.2.5 Reception of URA UPDATE by the UTRAN

When the UTRAN receives a URA UPDATE message, it shall transmit a URA UPDATE CONFIRM message on the downlink CCCH or DCCH.

8.3.2.5.1 Message URA UPDATE CONFIRM contents to set

UTRAN may allocate a new C-RNTI and/or a new U-RNTI for the UE. In that case UTRAN shall include those new identities in the IEs fnew C-RNTI;fnew U-RNTI;

The UTRAN shall assign the URA ID to the UE in the URA UPDATE CONFIRM message in a cell where multiple URAs are valid.

8.3.2.6 Reception of URA UPDATE CONFIRM by the UE

- When the UE receives a URA UPDATE CONFIRM message on the downlink CCCH or DCCH, it shall stop timer T303 and restart timer T306.

8.3.2.6.1 Message URA UPDATE CONFIRM contents to use

If the URA UPDATE CONFIRM message includes the IEs fnew C-RNTI and optionally fnew U-RNTI, the UE shall

- update its identities and transmit an RNTI REALLOCATION COMPLETE message on the uplink DCCH.

If the URA UPDATE CONFIRM message includes the IE 'URA ID,' the UE shall

- confirm whether indicated URA ID is in the list of URA IDs which is temporarily stored in the UE
- update URA ID and store in itself.

If the URA UPDATE CONFIRM message does not include the IE 'URA ID,' the UE shall

- confirm whether only one URA ID exists in the list of URA IDs which is temporarily stored in the UE
- update URA ID and stored in itself.

If the URA UPDATE CONFIRM message includes the IEs 'CN domain identity' and 'NAS system information,' the UE shall

- forward the content of the IE to the non-access stratum entity of the UE indicated by the IE 'CN domain identity.'

In all cases the UE shall, after other possible actions:

- retrieve secondary CCPCH info (for PCH) from the SYSTEM INFORMATION broadcasted from the new cell
- delete its C-RNTI and
- transit to URA_PCH state. The procedure ends.

8.3.2.7 Abnormal cases: Confirmation error of URA ID list

- When indicated URA ID is not included in the list of URA IDs or
- when the URA ID is not indicated and the list of URA IDs includes more than one URA ID,

the UE shall check the value of V303 and

- If V303 is smaller or equal than N303, the UE shall retransmit a URA UPDATE message on the uplink CCCH, restart timer T303 and increase counter V303. The UE shall set the IEs in the URA UPDATE message according to subclause 8.3.2.2.1 and 8.3.2.2.2
- If V303 is greater than N303, the UE shall enter idle mode. The procedure ends and a connection failure may be indicated to the non-access stratum. Other actions the UE shall perform when entering idle mode from connected mode are specified in subclause 8.5.2

8.3.2.8 Abnormal cases: T303 expiry or URA reselection

- Upon expiry of timer T303, and/or
- upon reselection of another UTRA cell when waiting for the URA UPDATE CONFIRM message,

the UE shall check the value of V303 and

- If V303 is smaller or equal than N303, the UE shall retransmit a URA UPDATE message on the uplink CCCH, restart timer T303 and increase counter V303. The UE shall set the IEs in the URA UPDATE message according to subclause 8.3.2.2.1 and 8.3.2.2.2
- If V303 is greater than N303, the UE shall enter idle mode. The procedure ends and a connection failure may be indicated to the non-access stratum. Other actions the UE shall perform when entering idle mode from connected mode are specified in subclause 8.5.2

8.3.2.9 Reception of RNTI REALLOCATION COMPLETE by the UTRAN

See subclause 8.3.3.4

8.3.3 RNTI reallocation

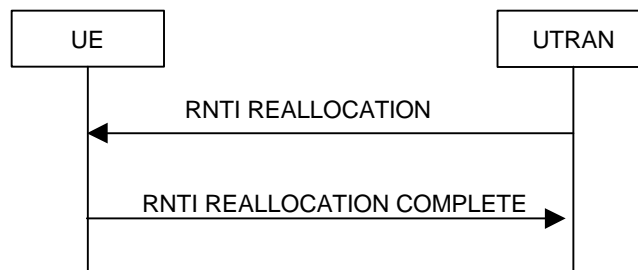

Figure 3936) RNTI reallocation procedure, normal flow

8.3.3.1 Purpose

The purpose with this procedure is to allocate a new C-RNTI and/or U-RNTI to an UE in connected mode.

8.3.3.2 Initiation

The UTRAN shall transmit an RNTI reallocation message to the UE on the downlink DCCH.

8.3.3.3 Reception of RNTI REALLOCATION by the UE

When the UE receives an RNTI REALLOCATION message, it shall take the actions in subclause 8.1.4.3.1 and then transmit an RNTI REALLOCATION COMPLETE message on the uplink DCCH. The procedure ends when the transmission of the RNTI REALLOCATION COMPLETE message has been confirmed by RLC.

8.3.3.3.1 Message RNTI REALLOCATION contents to use

If the IE *U-RNTI* are present, the UE shall store and start to use the values of these IEs as the current U-RNTI.

If the IE *C-RNTI* is present, the UE shall store and start to use the value of this IE.

If the IEs *CN domain identity* and *NAS system information* are included, the UE shall forward the content of the IE to the non-access stratum entity of the UE indicated by the IE *CN domain identity*.

8.3.3.4 Reception of RNTI REALLOCATION COMPLETE by the UTRAN

When the network receives RNTI REALLOCATION COMPLETE, UTRAN shall delete any old C-RNTI and U-RNTI. The procedure ends.

8.3.4 Active set update in soft handover

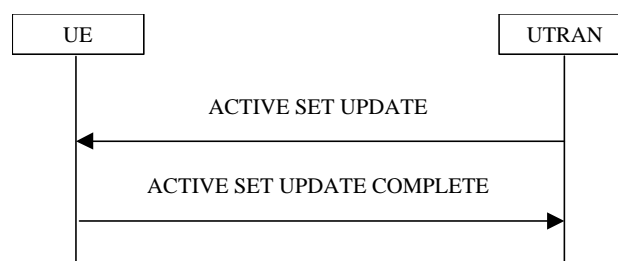

Figure 4037. Active Set Update procedure, successful case

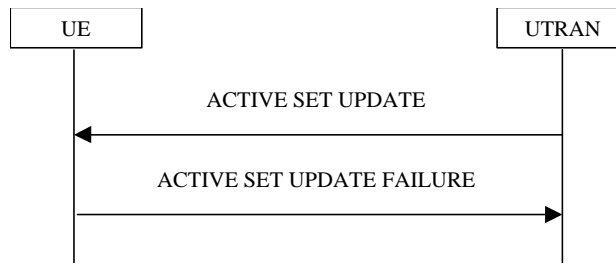

Figure 4138. Active Set Update procedure, failure case

The purpose of the active set update procedure is to update the active set of the connection between the UE and UTRAN. This procedure shall be used in CELL_DCH state. The UE should keep on using the old RLs while allocating the new RLs. Also the UE should keep on using the transmitter during the reallocation process.

8.3.4.1 Initiation

The procedure is initiated when UTRAN orders a UE in CELL_DCH state, to make the following modifications of the active set of the connection.

- a) Radio link addition
- b) Radio link removal
- c) Combined radio link addition and removal

In case a) and c), UTRAN shall

- prepare new additional radio link(s) in the UTRAN prior to the command to the UE.

In all cases, UTRAN shall

- send an ACTIVE SET UPDATE message on downlink DCCH using AM or UM RLC.
- Start timer T360.

8.3.4.1.1 Message ACTIVE SET UPDATE contents to set

UTRAN shall include the following information:

- IE Radio Link Addition Information: Downlink DPCH information and other optional parameters relevant for the additional radio links with Primary CCPCH info used for the reference ID to indicate which radio link to add. This IE is need in case a) and c).
- IE Radio Link Removal Information: Primary CCPCH info used for the reference ID to indicate which radio link to remove. This IE is need in case b) and c).

If SRNC relocation is performed simultaneously during active set update when all radio links are replaced simultaneously, the UTRAN shall include the "U-RNTI" IE and CN domain identity and NAS system information IEs in the messages.

8.3.4.2 Reception of message ACTIVE SET UPDATE by the UE

The UE shall take the following actions:

- Upon reception of a ACTIVE SET UPDATE message the UE shall perform actions according to subclause 8.3.4.2.1 and transmit an ACTIVE SET UPDATE COPMLETE message on the uplink DCCH using AM RLC. When the transmission of the ACTIVE SET UPDATE COMPLETE message has been confirmed by RLC the procedure ends.

8.3.4.2.1 Message ACTIVE SET UPDATE contents to use

The UE shall

- at first, add the RLCs indicated in the IE "Radio Link Addition Information".
- remove the RLCs indicated in the IE "Radio Link Removal Information".

If the UE active set is full or becomes full, an RLC, which is indicated to remove, shall be removed before adding RLC, which is indicated to add.

If the ACTIVE SET UPDATE message includes the "U-RNTI" IE, the UE shall update its identity.

If the ACTIVE SET UPDATE message includes the IEs "CN domain identity" and "NAS system information", the UE shall forward the content of the IE to the non-access stratum entity of the UE indicated by the IE "CN domain identity".

8.3.4.2.2 Message ACTIVE SET UPDATE COMPLETE contents to set

UE shall include the following information:

- IE "physical CH information elements": optional parameters relevant for the new active set.

8.3.4.3 Abnormal case: Unsupported configuration in the UE

If UTRAN instructs the UE to use a configuration that it does not support, the UE shall

- Transmit a ACTIVE SET UPDATE FAILURE message on the DCCH using AM RLC.

8.3.4.3.1 Message ACTIVE SET UPDATE FAILURE contents to set

UE shall include the following information:

- IE "failure cause": "configuration unacceptable".

8.3.4.4 Reception of message ACTIVE SET UPDATE COMPLETE by the UTRAN

When the UTRAN has received the ACTIVE SET UPDATE COMPLETE message,

- the UTRAN may remove radio link(s) which are indicated to remove to the UE in case b) and c)
- and the UTRAN stops the T360 and the procedure ends on the UTRAN side.

8.3.4.5 Reception of message ACTIVE SET UPDATE FAILURE by the UTRAN

When the UTRAN has received the ACTIVE SET UPDATE FAILURE message, the UTRAN may delete radio links which are indicated to add to the UE. The UTRAN stops the T360 and the procedure ends on the UTRAN side.

8.3.4.6 Abnormal case: T360 timeout

Upon expiry of timer T360 and no ACTIVE SET UPDATE COMPLETE or ACTIVE SET UPDATE FAILURE message has been received, the UTRAN may delete the new and old radio links. After the UTRAN deleted all the radio links, the UTRAN may wait for the UE to request a re-establishment of the RRC Connection. The UE context may then be cleared, unless the UE requests a re-establishment of the RRC Connection for a certain time period.

8.3.5 Hard handover

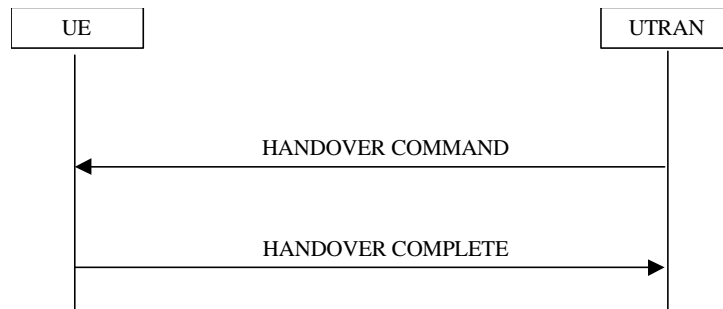

Figure 4239. Hard handover, successful case

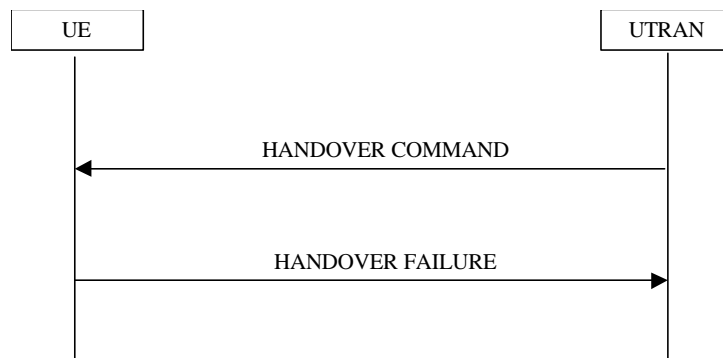

Figure 4340. Hard handover, failure case

8.3.5.1 General

The purposes of the hard handover procedure are;

- to change the radio frequency band of the connection between the UE and UTRAN
- to change the cell on the same frequency but no network support of macro diversity, and
- to change the mode between TDD and FDD.

This procedure may be used in CELL_DCH state.

8.3.5.2 Initiation

UTRAN shall

- Configure new radio links in new physical configuration and L1 starts TX/RX on the new links immediately.
- Start timer T358.
- Send a HANDOVER COMMAND message on downlink DCCH using AM or UM RLC.

8.3.5.2.1 Message HANDOVER COMMAND contents to set

UTRAN shall include the following information:

IE physical CH information elements: frequency info, uplink radio resources, downlink radio resources and other optional parameters relevant for the target physical CH configuration in new physical configuration.

If SRNC relocation is performed simultaneously during active set update, the UTRAN shall include the "U-RNTI" IE and CN domain identity and NAS system information IEs in the HANDOVER COMMAND message.

8.3.5.3 Reception of message HANDOVER COMMAND by the UE

The UE shall take the following actions:

- Upon reception of a HANOVER COMMAND message the UE shall perform actions according to subclause 8.3.5.3.1 and transmit a HANOVER COMPLETE message on the uplink DCCH using AM RLC. When the transmission of the HANOVER COMPLETE message has been confirmed by RLC the procedure ends.
- The UE shall be able to receive an HANOVER COMMAND message and perform an hard handover, even if no prior UE measurements have been performed on the target cell and/or frequency
- The UE in CELL_DCH is allowed to release all resources for the old connection before allocation of the new resources. The UE should also turn off the transmitter when the resource reallocation process takes place.

8.3.5.3.1 Message HANOVER COMMAND contents to use

The UE shall

- Release the old physical CH configuration.
- Re-establish the physical CH configuration on new physical configuration according to the IE Physical CH

If the HANOVER COMMAND message includes the "U-RNTI" IE, the UE shall update its identity.

If the HANOVER COMMAND message includes the IEs "CN domain identity" and "NAS system information", the UE shall forward the content of the IE to the non-access stratum entity of the UE indicated by the IE "CN domain identity".

The UE shall perform actions for other IEs according to subclause 8.5.7.

8.3.5.3.1 Message HANOVER COMPLETE contents to set

UE shall include the following information:

- IE "physical CH information elements" optional parameters relevant for the target physical CH configuration in new physical configuration.

8.3.5.4 Abnormal case: Unsupported configuration in the UE

If UTRAN instructs the UE to use a configuration that it does not support, the UE shall

- Transmit a HANOVER FAILURE message on the DCCH using AM RLC.

8.3.5.4.1 Message HANOVER FAILURE contents to set

UE shall include the following information:

- IE "failure cause" to "configuration unacceptable".

8.3.5.5 Abnormal case: Physical channel failure

If the UE fails to establish the physical channel(s) indicated in the message HANOVER COMMAND the UE shall

- Revert to the configuration prior to the reception of the HANOVER COMMAND message (old configuration) and transmit a HANOVER FAILURE message on the DCCH using AM RLC. The procedure ends and the UE resumes the normal operation as if no hard handover attempt had occurred.

Criteria to be fulfilled for having a physical channel established are specified in subclause 8.5.4

If the UE is unable to revert back to the old configuration, the UE shall

- Initiate a RRC connection re-establishment procedure according to subclause 8.1.5

8.3.5.5.1 Message HANOVER FAILURE contents to set

UE shall include the following information:

- IE "failure cause" to "physical channel failure".

8.3.5.6 Reception of message HANOVER COMPLETE by the UTRAN

When the UTRAN has received the HANOVER COMPLETE message, UTRAN may delete any old configuration.

Timer T358 is stopped and the procedure ends on the UTRAN side.

8.3.5.7 Reception of message HANDOVER FAILURE by the UTRAN

When the UTRAN has received the HANDOVER FAILURE message, UTRAN may delete any new configuration. Timer T358 is stopped and the procedure ends on the UTRAN side.

8.3.5.8 Abnormal case: T358 timeout

Upon expiry of timer T358 and no HANDOVER COMPLETE or HANDOVER FAILURE message has been received, the UTRAN may delete the old and new configuration. After the UTRAN deleted all the configurations, the UTRAN may wait for the UE to request a re-establishment of the RRC Connection. The UE context may then be cleared, unless the UE requests a re-establishment of the RRC Connection for a certain time period.

8.3.6 Inter-system handover to UTRAN



Figure 4441. Inter system handover to UTRAN, successful case

8.3.6.1 General

The purpose of the inter system handover procedure is to , controlled by the network, transfer a connection between the UE and another radio access system (e.g. GSM) to UTRAN.

8.3.6.2 Initiation

The procedure is initiated when the UE is connected to another radio access system than UTRAN, e.g. GSM, and, using system specific procedures, is ordered by that radio access system to make a handover to UTRAN.

A message XXXX is sent to the UE via the system from which inter- system handover is performed.

[Editor's note: Message XXXX needs to be defined.]

8.3.6.2.1 Message XXXX contents to set

UTRAN should provide the following information to the other system to be included in the XXXX message.

- UE information elements
- RAB information elements
- TrCH information elements
- PhyCH information elements

If the other radio access system also provide other information is FFS.

8.3.6.3 Reception of message XXXX by the UE

The UE shall take the following actions:

- If the UE succeeds to establish the connection to UTRAN, it shall transmit a HANDOVER COMPLETE message

on the uplink DCCH

8.3.6.3.1 Message XXXX contents to use

The UE shall

- Store the value of the IE U-RNTI and
- Initiate the signalling link parameters according to the IEs Signalling link type and RB mapping info.

If additional RB IEs are included, the UE shall

- use the multiplexing option applicable for the transport channels used according to the IE RB mapping info.
- Configure MAC multiplexing if that is needed in order to use said transport channel(s).
- Use MAC logical channel priority when selecting TFC in MAC.

If the IE C-RNTI is included, the UE shall

- Use that C-RNTI when using common transport channels of type RACH, FACH and CPCH in the current cell.

If neither the IEs PRACH info nor Uplink DPCH info is included, the UE shall

- Let the physical channel of type PRACH that is given in system information be the default in uplink and enter the CELL_FACH state.

If neither the IEs Secondary CCPCCH info nor Downlink DPCH info is included, the UE shall

- Start to receive the physical channel of type Secondary CCPCCH that is given in system information.

The UE shall use the transport channel(s) applicable for the physical channel types that is used. If neither the IE TFS is included or previously stored in the UE for that transport channel(s), the UE shall

- Use the TFS given in system information

If none of the TFS stored is compatible with the physical channel, the UE shall

- Delete stored TFS and use the TFS given in system information

Actions that shall be performed by the UE, for other IEs are specified in subclause 8.5.7

8.3.6.3.2 Message HANDOVER COMPLETE contents to set

There are no requirements on the UE concerning the information elements to be provided within the handover complete message.

8.3.6.4 Abnormal case: UE fails to perform handover

If the UE does not succeed to establish the connection to UTRAN, it shall terminate the procedure including release of the associated resources and indicate the failure to the other radio access system.

Upon receiving an indication about the failure from the other radio access system, UTRAN should release the associated resources and the context information concerning this UE.

8.3.6.5 Reception of message HANDOVER COMPLETE by the UTRAN

Upon receiving a HANDOVER COMPLETE message, UTRAN should consider the inter-system handover procedure as completed successfully and indicate this to the CN.

8.3.6.5.1 Message HANDOVER COMPLETE contents to use

There are no requirements on UTRAN concerning the handling of information elements included in the HANDOVER COMPLETE message.

8.3.7 Inter-system handover from UTRAN



Figure 4542. Inter system handover from UTRAN, successful case

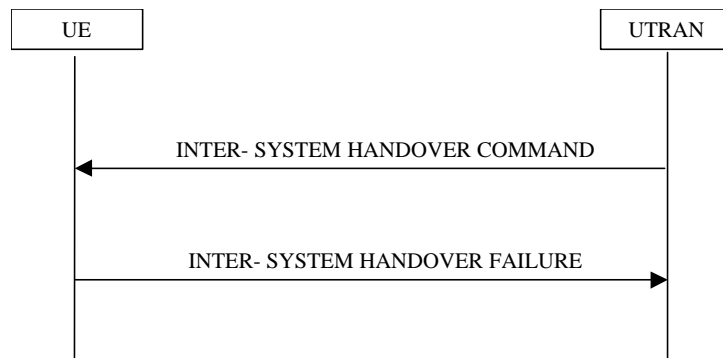

Figure 4643. Inter system handover from UTRAN, failure case

8.3.7.1 General

The purpose of the inter system handover procedure is to, controlled by the network, transfer a connection between the UE and UTRAN to another radio access system (e.g. GSM). This procedure may be used in CELL_DCH and CELL_FACH state.

8.3.7.2 Initiation

The procedure is initiated when UTRAN orders a UE in CELL_DCH or CELL_FACH state, to make a handover to another radio access system than UTRAN, e.g. GSM.

UTRAN shall.

- start timer T359 and
- send an INTER- SYSTEM HANDOVER COMMAND message.

8.3.7.2.1 Message INTER- SYSTEM HANDOVER COMMAND contents to set

UTRAN shall include the following information:

- IE 'inter system message': candidate/ target cell identifier(s), radio parameters relevant for the other radio access system

8.3.7.3 Reception of message INTER- SYSTEM HANDOVER COMMAND by the UE

The UE shall take the following actions:

- If the UE succeeds to establish the connection to other radio access system, the release of the UMTS radio resources is initiated by the other system.

8.3.7.3.1 Message INTER- SYSTEM HANDOVER COMMAND contents to use

There are no requirements on the UE concerning the handling of information elements included in the HANDOVER COMPLETE message.

8.3.7.4 Successful completion of the inter-system handover

Upon successfully completing the handover, UTRAN should release the radio connection and remove all context information for the concerned UE.

8.3.7.5 Abnormal case: UE fails to complete requested handover

If the UE does not succeed to establish the connection to the other radio access system, it shall

- resume the connection to UTRAN using the resources used before receiving the INTER-SYSTEM HANDOVER COMMAND and
- transmit the INTER-SYSTEM HANDOVER FAILURE message.

8.3.7.5.1 Message INTER-SYSTEM HANDOVER FAILURE contents to set

FFS

8.3.7.6 Reception of INTER-SYSTEM HANDOVER FAILURE by UTRAN

Upon receiving INTER-SYSTEM HANDOVER FAILURE message UTRAN should stop timer T359.

8.3.7.7 Abnormal case: expiry of timer T359 in UTRAN

In case timer T359 expires while UTRAN is waiting for a CN initiated release, UTRAN should indicate a radio connection failure and wait for the CN to release the radio connection.

8.3.8 Inter-system cell reselection to UTRAN

8.3.8.1 General

The purpose of the inter system cell reselection procedure to UTRAN is to, controlled by the UE and to some extent the other radio access system, transfer a connection between the UE and another radio access system (e.g. GSM/GPRS) to UTRAN.

8.3.8.2 Initiation

When the UE makes an inter-system cell reselection to UTRAN according to the criteria specified in TS 25.304, it shall initiate this procedure. The inter-system cell reselection made by the UE may use system information broadcast from the other radio access system or UE dedicated information.

The UE shall initiate an RRC connection establishment procedure as specified in subclauses 8.1.3 and 8.3.8.2.1 After initiating an RRC connection establishment, the UE shall release all resources specific to the other radio access system.

8.3.8.2.1 Message RRC CONNECTION REQUEST contents to set

- The UE shall set the IE 'establishment cause' to 'inter-system cell reselection'
- Other IEs shall be set according to subclause 8.1.3.2.1

8.3.8.3 Abnormal case: UE fails to complete an inter-system cell reselection

If the inter-system cell reselection fails before the UE has initiated the RRC connection establishment the UE may return back to the other radio access system.

If the RRC connection establishment fails the UE shall enter idle mode.

8.3.9 Inter-system cell reselection from UTRAN

8.3.9.1 General

The purpose of the inter system cell reselection procedure from UTRAN is to, controlled by the UE and to some extent

the network, transfer a connection between the UE and UTRAN to another radio access system (e.g. GSM/GPRS).

8.3.9.2 Initiation

This procedure may be initiated in states CELL_FACH or CELL_PCH. *[Note: the usage of the procedure in state URA_PCH is FFS.]*

When the UE based on received system information makes a cell reselection to another radio access system than UTRAN, e.g. GSM/GPRS, according to the criteria specified in TS 25.304, the UE shall.

- start timer T309
- initiate an establishment of a connection to the other radio access system according to its specifications

8.3.9.3 Successful cell reselection

When the UE succeeds to reselect a cell in the other radio access system and initiated an establishment of a connection, it shall stop timer T309 and release all UTRAN specific resources.

UTRAN should release all UE dedicated resources upon indication that the UE has completed a connection establishment to the other radio access system.

8.3.9.4 Expiry of timer T309

If the timer T309 expires before the UE succeeds to initiate an establishment of a connection to the other radio access system it shall resume the connection to UTRAN.

8.4 Measurement procedures

The UE measurements are grouped into 6 different types of measurements, according to what the UE should measure. The different types of measurements are:

- **Intra-frequency measurements:** measurements on downlink physical channels at the same frequency as the active set. Detailed description is found in subclause 14.1.
- **Inter-frequency measurements:** measurements on downlink physical channels at frequencies that differ from the frequency of the active set.
- **Inter-system measurements:** measurements on downlink physical channels belonging to another radio access system than UTRAN, e.g. PDC or GSM.
- **Traffic volume measurements:** measurements on uplink traffic volume. Detailed description is found in subclause 14.2.
- **Quality measurements:** Measurements of quality parameters, e.g. downlink transport block error rate.
- **Internal measurements:** Measurements of UE transmission power and UE received signal level. Detailed description is found in subclause 14.3.

The same type of measurements may be used as input to different functions in UTRAN. However, the UE shall support having a number of measurements running in parallel. The UE shall also support that each measurement is controlled and reported independently of each other.

Cells that the UE is monitoring (e.g. for handover measurements) are grouped in the UE into two different categories:

1. Cells that belong to the **active set**. In TDD: Always only one cell belongs to an active set. User information is sent from all these cells and they are simultaneously demodulated and coherently combined. In FDD, these cells are involved in soft handover.
2. Cells that are not included in the active set, but are monitored belong to the **monitored set**.

UTRAN may start a measurement in the UE by transmitting a MEASUREMENT CONTROL message. This message includes

1. **Measurement type:** One of the types listed above describing what the UE shall measure.
2. **Measurement identity number:** A reference number that should be used by the UTRAN when modifying or releasing the measurement and by the UE in the measurement report.
3. **Measurement command:** One out of three different measurement commands
 - Setup: Setup a new measurement.
 - Modify: Modify a previously defined measurement, e.g. to change the reporting criteria.
 - Release: Stop a measurement and clear all information in the UE that are related to that measurement.
4. **Measurement objects:** The objects the UE shall measure on, and corresponding object information.
5. **Measurement quantity:** The quantity the UE shall measure. This also includes the filtering of the measurements.
6. **Reporting quantities:** The quantities the UE shall include in the report in addition to the quantities that are mandatory to report for the specific event.
7. **Measurement reporting criteria:** The triggering of the measurement report, e.g. periodical or event-triggered reporting. The events are described for each measurement type in chapter 14.
8. **Reporting mode:** This specifies whether the UE shall transmit the measurement report using acknowledged or unacknowledged data transfer of RLC.

All these measurement parameters depend on the measurement type and are described in more detail in chapter 14.

When the reporting criteria is fulfilled, i.e. the specified event occurred or the time since last report indicated for periodical reporting has elapsed, the UE shall send a MEASUREMENT REPORT to UTRAN.

In idle mode the UE shall perform measurements according to the measurement control messages sent in SYSTEM INFORMATION on the BCCH. A UE in connected mode that has not received a dedicated measurement control message shall also use the measurement control messages sent in SYSTEM INFORMATION on the BCCH.

The UTRAN may divide the measurement control information in SYSTEM INFORMATION into idle mode and connected mode SIBs. However, if connected mode information is missing, a connected mode UE shall use the same measurement control message as for idle mode.

On the DCH, the UE shall report radio link related measurements to the UTRAN with a MEASUREMENT REPORT message. In order to receive information for the establishment of immediate macrodiversity (FDD) or to support the DCA algorithm (TDD), the UTRAN may also request the UE to append radio link related measurement reports to the following messages sent on the RACH:

- RRC CONNECTION REQUEST sent to establish an RRC connection.
- RRC CONNECTION RE-ESTABLISHMENT REQUEST sent to re-establish an RRC connection.
- DIRECT TRANSFER sent uplink to establish a signalling connection.
- CELL UPDATE sent to respond to a UTRAN originated page.
- MEASUREMENT REPORT sent to report uplink traffic volume.
- CAPACITY REQUEST sent to request PUSCH capacity (TDD only)

[Note: Whether or not measured results can be appended to other messages and in other scenarios is FFS.]

8.4.1 Measurement control



Figure 4744. Measurement Control, normal case

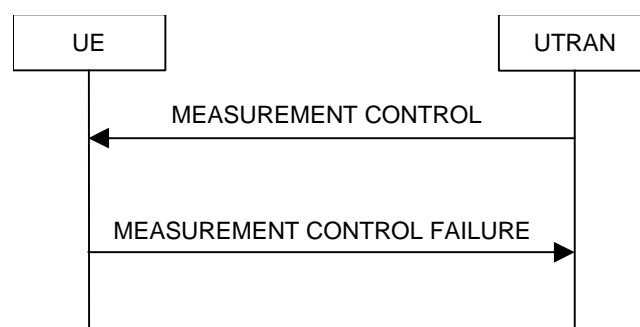

Figure 4845. Measurement Control, UE reverts to old measurements

8.4.1.1 General

The purpose with this procedure is to Setup, Modify or Release a measurement in the UE.

8.4.1.2 Initiation

The UTRAN may request a measurement in the UE to be setup, modified or released.

UTRAN shall transmit a MEASUREMENT CONTROL message on the downlink DCCH using AM RLC.

8.4.1.2.1 Message MEASUREMENT CONTROL contents to set

When a new measurement is setup, UTRAN should set the IE 'measurement identity number' to a value that is not used for other measurements.

UTRAN should take the UE capabilities into account when a measurement is configured in the UE.

[Editor's note: Other IEs are included and set according to selection by the UTRAN.]

8.4.1.3 Reception of MEASUREMENT CONTROL by the UE

Upon reception of a MEASUREMENT CONTROL message the UE shall perform actions according to subclause 8.4.1.3.1. These actions end the procedure.

8.4.1.3.1 Message MEASUREMENT CONTROL contents to use

The UE shall

- Read the IE 'measurement command'

If the IE 'measurement command' has the value 'setup', the UE shall

- Associate this measurement with the identity number given in the IE 'measurement identity number'
- Store the IEs giving 'measurement objects', 'measurement quantity', 'reporting quantity', 'measurement reporting criteria' and 'reporting mode' that are valid for this measurement type and
- Start measurements according to the stored IEs for this measurement identity number

See chapter 14 for detailed description of measurement object, measurement quantity and measurement reporting criteria for the different types of measurements.

If the IE 'measurement command' has the value 'modify', the UE shall

- Retrieve the stored measurement IEs associated with the identity given in the IE 'measurement identity number'
- If any of the IEs giving 'measurement objects', 'measurement quantity', 'reporting quantity', 'measurement reporting criteria' or 'reporting mode' are present in the MEASUREMENT CONTROL message, that IE shall replace the corresponding stored IE.
- Store the new set of IEs and associate them with the measurement identity number and
- Resume the measurements according to the new stored set of measurement IEs

If the IE 'measurement command' has the value 'release', the UE shall

- Stop the measurement associated with the identity given in the IE 'measurement identity number'
- Clear all stored configuration related to this measurement

8.4.1.4 Abnormal case: Unsupported measurement in the UE

If UTRAN instructs the UE to perform a measurement that is not supported by the UE, the UE shall

- Keep the measurement configuration that was valid before the MEASUREMENT CONTROL message was received.
- Transmit a MEASUREMENT CONTROL FAILURE message on the DCCH using AM RLC.

8.4.1.4.1 Message MEASUREMENT CONTROL FAILURE contents to set

The UE shall set the cause value in IE 'failure cause' to 'unsupported measurement'.

8.4.1.5 Reception of MEASUREMENT CONTROL FAILURE by the UTRAN

When UTRAN receives MEASUREMENT CONTROL FAILURE message the procedure ends.

8.4.2 Measurement report



Figure 4946. Measurement report, normal case

8.4.2.1 Purpose

The purpose with this procedure is to transfer measurement results from the UE to UTRAN.

8.4.2.2 Initiation

The UE shall transmit a MEASUREMENT REPORT on the uplink DCCH when the reporting criteria are fulfilled for any of the measurements that are performed in the UE.

Criteria is fulfilled if either

- The time indicated in the stored IE 'periodical reporting' has elapsed since the last measurement report with this measurement identity number was sent or initiated, or
- Event in stored IE 'measurement reporting criteria' was triggered. Detailed event description and report trigger mechanisms that may be setup in the UE by UTRAN, for the different measurement types are described in Chapter 14.

The UE shall transmit the MEASUREMENT REPORT using either AM or UM RLC according to the stored IE 'measurement reporting mode' associated with the measurement identity number that triggered the report.

8.4.2.2.1 Message MEASUREMENT REPORT contents to set

For the measurement that triggered the MEASUREMENT REPORT message, the UE shall

- Set the IE 'measurement identity number' to the measurement identity number that is associated with that measurement
- Set the IE 'measured results' to include measurements according to the stored IE 'reporting quantity' of that measurement

If the MEASUREMENT REPORT message was triggered by an event (i.e. not a periodical report), the UE shall

- Set the measurement event results according to the event that triggered the MEASUREMENT REPORT message

8.4.2.3 Reception of MEASUREMENT REPORT by the UTRAN

When UTRAN receives the MEASUREMENT REPORT message the procedure ends.

8.5 General procedures

8.5.1 Selection of initial UE identity

FFS

8.5.2 Actions when entering idle mode

FFS

8.5.3 Actions when entering CELL_DCH state

FFS

8.5.4 Physical channel establishment criteria

FFS

8.5.5 Detection of out of service area

FFS

8.5.6 Radio link failure criteria

FFS

8.5.7 Default actions on receipt of an information element

When any of the following IEs are received by the UE in any RRC message, the UE shall perform the actions specified below, unless specified otherwise.

8.5.7.1 CN information elements

8.5.7.2 UTRAN mobility information elements

8.5.7.3 UE information elements

8.5.7.3.1 Activation time

If the IE 'Activation time' is present, the UE shall

- activate the new configuration present in the same message as this IE at the indicated time.

[Editor's note: The new configuration is typically a dedicated physical channel present in the same message as the

8.5.7.3.6 UTRAN DRX Cycle length

The UE may use Discontinuous Reception (DRX) in Cell_PCH or URA_PCH state in order to reduce power consumption. When DRX is used the UE needs only to monitor at one PICH Monitoring Occasion within one Paging Occasion per DRX cycle. See section 3.1 of TS 25.304 for definitions. The DRX cycle length shall be $2^k \cdot \text{PBP}$ frames, where k is an integer and PBP is the paging block periodicity.

If the IE UTRAN DRX cycle length is included, the UE shall

- Store that value as the current UTRAN DRX Cycle length

8.5.7.3.7 DRX Indicator

If the IE "DRX Indicator" is included and is set to, DRX with cell updating, the UE shall

- use the current UTRAN DRX Cycle length and
- calculate frame number for the Paging Occasions by using the same formula as in Idle Mode, see section 8 of TS 25.304,
- calculate the PICH Monitoring Occasions by using the same formula as in Idle Mode. See section 8 of TS25.304.

If the IE "DRX Indicator" is included and is set to, DRX with URA updating, the UE shall

- use the current UTRAN DRX Cycle length and
- calculate frame number for the Paging Occasions by using the same formula as in Idle Mode, see section 8 of TS 25.304,
- calculate the PICH Monitoring Occasions by using the same formula as in Idle Mode. See section 8 of TS25.304.

If no IMSI is available, the UE should use a default number xxxx (tbd) instead of IMSI in the formulas defined for calculations of the frame number the Paging Occasion Occur and the PICH Monitoring Occasion.

If the IE "DRX Indicator" is included and is set to, no DRX the UE shall

- stop using DRX.

8.5.7.4 Radio bearer information elements

8.5.7.4.1 RB mapping info

If the IEs RB identity'and RB mapping info'are included, the UE shall

- If any, delete all previously stored multiplexing options for that radio bearer.
- Store each new multiplexing option for that radio bearer.

8.5.7.4.2 RLC Info

If the IEs RB identity'and RLC Info'are included, the UE shall

- Configure the transmitting and receiving RLC entities in the UE for that radio bearer accordingly.

8.5.7.5 Transport channel information elements

8.5.7.5.1 Transport Format Set

If the IEs transport channel identity'and Transport format set'is included, the UE shall

- store the transport format set for that transport channel.

8.5.7.5.2 Transport format combination set

If the IE Transport format combination set'is included, the UE shall

- start to respect those transport format combinations.

8.5.7.5.3 Transport format combination subset

If the IE Transport format combination subset'is included, the UE shall

- restrict the transport format combination set to that transport format combination subset. If the transport format combination subset indicates the full transport format combination set'any restriction on transport format combination set is released and the UE may use the full transport format combination set.

8.5.7.6 Physical channel information elements

8.5.7.6.1 Frequency info

If the IE Frequency info is included the UE shall

- Store that frequency as the active frequency and
- Tune to that frequency.

If the IE Frequency info is not included and the UE has a stored active frequency, the UE shall

- Continue to use the stored active frequency

If the IE Frequency info is not included and the UE has no stored active frequency, it shall

- map any used physical channels on the frequency given in system information as default

8.5.7.6.2 PRACH info

If the IE PRACH info is included, the UE shall

- Release any active dedicated physical channels in the uplink and
- let the PRACH be the default in the uplink for RACH

8.5.7.6.3 Secondary CCPCH info

If the IE Secondary CCPCH info is included and the IE PICH info is not included, the UE shall

- Start to receive that Secondary CCPCH in the downlink and
- enter the CELL_FACH state if not already in that state.

8.5.7.6.4 Uplink DPCH info

If the IE Uplink DPCH info is included, the UE shall

- Release any active uplink physical channels, activate the given physical channels and
- enter the CELL_DCH state if not already in that state. Additional actions the UE shall perform when entering the CELL_DCH state from another state are specified in subclause 8.5.3

8.5.7.6.5 Downlink DPCH info

If the IE Downlink DPCH info is included, the UE shall

- Activate the dedicated physical channels indicated by that IE

8.5.7.6.6 Maximum allowed UL TX power

If the IE Maximum allowed UL TX power is included, the UE shall

- Keep the UE uplink transmit power below the indicated power value. If the current UE uplink transmit power is above the indicated power value, the UE shall decrease the power to a level below the power value.

8.5.7.7 Measurement information elements

8.5.7.8 Other information elements

9 Protocol states

9.1 RRC States and State Transitions including GSM

[Figure 50](#)~~Figure 84~~[Error! Reference source not found.](#) shows the RRC states in Connected Mode, including transitions between UTRAN connected mode and GSM connected mode for PSTN/ISDN domain services, and between UTRAN connected mode and GSM/GPRS packet modes for IP domain services. It also shows the transitions between Idle Mode and UTRAN Connected Mode and further the transitions within UTRAN connected Mode.

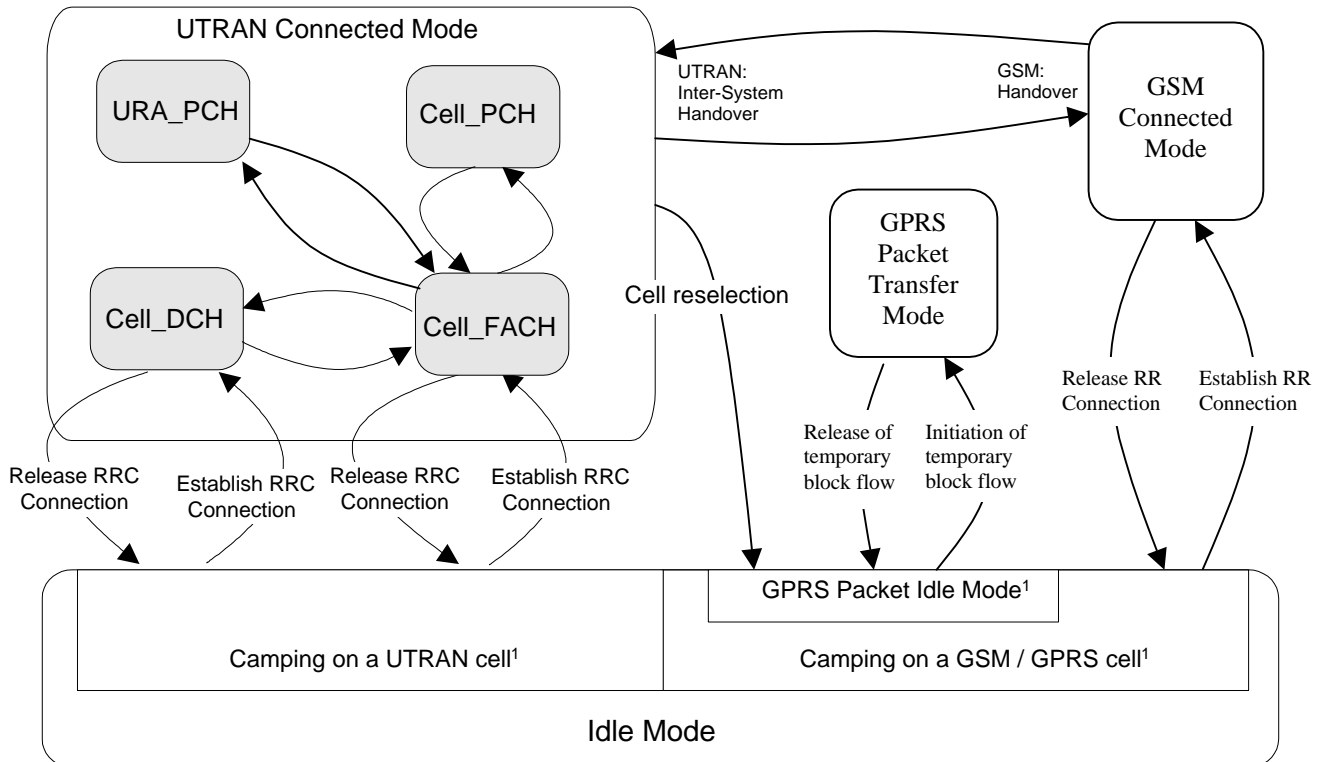

Figure 5081: RRC States and State Transitions including GSM

¹: The indicated division within Idle Mode is only included for clarification and shall not be interpreted as states.]

It shall be noted that not all states may be applicable for all UE connections. For a given QoS requirement on the UE connection, only a subset of the states may be relevant.

After power on, the UE stays in Idle Mode until it transmits a request to establish an RRC Connection. In Idle Mode the connection of the UE is closed on all layers of the UTRAN. In Idle Mode the UE is identified by non-access stratum identities such as IMSI, TMSI and P-TMSI. In addition, the UTRAN has no own information about the individual Idle Mode UE:s, and it can only address e.g. all UE:s in a cell or all UE:s monitoring a paging occasion. The UE behaviour within this mode is described in /4/.

The UTRAN Connected Mode is entered when the RRC Connection is established. The UE is assigned a radio network temporary identity (RNTI) to be used as UE identity on common transport channels. [Note: The exact definition of RRC connection needs further refinement.] The RRC states within UTRAN Connected Mode reflect the level of UE connection and which transport channels that can be used by the UE.

For inactive stationary data users the UE may fall back to PCH on both the Cell or URA levels. That is, upon the need for paging, the UTRAN shall check the current level of connection of the given UE, and decide whether the paging message shall be sent within the URA, or should it be sent via a specific cell.

9.2 Transition from Idle Mode to UTRAN Connected Mode

The transition to the UTRAN Connected Mode from the Idle Mode can only be initiated by the UE by transmitting a request for an RRC Connection. The event is triggered either by a paging request from the network or by a request from upper layers in the UE.

When the UE receives a message from the network that confirms the RRC connection establishment, the UE enters the CELL_FACH or CELL_DCH state of UTRAN Connected Mode.

In the case of a failure to establish the RRC Connection the UE goes back to Idle Mode. Possible causes are radio link failure, a received reject response from the network or lack of response from the network (timeout).

9.3 UTRAN Connected Mode States and Transitions

9.3.1 CELL_DCH state

The CELL_DCH state is characterized by

- A dedicated physical channel is allocated to the UE in uplink and downlink.
- The UE is known on cell level according to its current active set.
- Dedicated transport channels, downlink and uplink (TDD) shared transport channels, and a combination of these transport channels can be used by the UE.

The CELL_DCH-state is entered from the Idle Mode through the setup of an RRC connection, or by establishing a dedicated physical channel from the CELL_FACH state.

A PDSCH may be assigned to the UE in this state, to be used for a DSCH. In TDD a PUSCH may also be assigned to the UE in this state, to be used for a USCH.

9.3.1.3 Transition from CELL_DCH to Idle Mode

Transition to Idle Mode is realised through the release of the RRC connection.

9.3.1.4 Transition from CELL_DCH to CELL_FACH state

Transition to CELL_FACH state can occur either

- a) through the expiration of an inactivity timer (T_{DCH}),
- b) at the end of the time period for which the dedicated / shared channel was allocated or
- c) via explicit signalling.

9.3.1.5 Radio Resource Allocation tasks (CELL_DCH)

For the DCH, several physical channel allocation strategies may be applied. The allocations can be either permanent (needing a DCH release message) or based on time or amount-of-data.

Resource allocation can be done separately for each packet burst with fast signalling on the DCH

For each radio frame the UE and the network indicate the current data rate (in uplink and downlink respectively) using the transport format combination indicator (TFCI). However, in TDD, DCH and DSCH or USCH may be mapped on different CCTrCHs, their TFCI are totally independent. DCH transmission is not modified by the simultaneous existence of DSCH/USCH. If the configured set of combinations (i.e. transport format set for one transport channel) are found to be insufficient to retain the QoS requirements for a transport channel, the network initiates a reconfiguration of the transport format set (TFS) for that transport channel. This reconfiguration can be done during or in between data transmission. Further, the network can reconfigure the physical channel allowing an increase or decrease of the peak data rate.

For the uplink data transmission, the UE reports the observed traffic volume to the network in order for the network to re-evaluate the current allocation of resources. This report contains e.g. the amount of data to be transmitted or the buffer status in the UE.

If during data transfer the UE is unable to transmit at the requested output power when using the peak allocated capacity, the UE shall reduce transmission rate within the current 10 ms radio frame in order to maintain the closed-loop power control.

9.3.1.6 RRC Connection mobility tasks (CELL_DCH)

Depending on the amount and frequency of data macrodiversity (soft handover) may or may not be applied. The RRC Connection mobility is handled by measurement reporting, soft handover and hard handover procedures.

9.3.1.7 Localised Service Area (LSA) support

[Editor's note: A liaison statement to SMG12 has been sent to receive guidance on the functionalities that would need to be defined in UTRAN to support SoLSA-like (Support of LSA, GSM) services.]

In case of a network-controlled handover procedure, UTRAN shall take into account the local support of LSA service and the eventual subscription information of the UE to those LSA regarding the provision of service to the UE.

Regarding soft handover, the following principles are applied by UTRAN:

- For "LSA only" UE, the RRC connection shall be maintained by UTRAN as long as at least one cell of the active set belongs to a UE subscribed LSA.
- For "LSA exclusive access" cells, UTRAN shall prevent such cell from being part of the active set if the UE has not subscribed to the corresponding LSA

Regarding network controlled hard handover, the following principles are applied by UTRAN:

- For "LSA only" UE, UTRAN shall prevent the UE from being handed over a cell which does not belong to a UE subscribed LSA.
- For "LSA exclusive access" cells, UTRAN shall prevent the UE from being handed over such a cell if the UE has not subscribed to the corresponding LSA

9.3.1.8 UE Measurements (CELL_DCH)

The UE shall perform measurements and transmit measurement reports according to the measurement control information.

The UE shall use the connected mode measurement control information received in other states until new measurement control information has been assigned to the UE.

9.3.1.9 Transfer and update of system information (CELL_DCH)

UEs with certain capabilities shall read system information broadcast on FACH. *[Editors note: Currently it is only UEs having DRAC capabilities that need to read system information on FACH.]*

9.3.2 CELL_FACH state

The CELL_FACH state is characterised by:

- No dedicated physical channel is allocated to the UE.
- The UE continuously monitors a FACH in the downlink
- The UE is assigned a default common or shared transport channel in the uplink (e.g. RACH) that it can use anytime according to the access procedure for that transport channel
- The position of the UE is known by UTRAN on cell level according to the cell where the UE last made a cell update.
- In TDD mode, one or several USCH or DSCH transport channels may have been established.

In the CELL_FACH substate the UE shall perform the following actions:

- listens to an FACH
- listens to the BCH transport channel of the serving cell for the decoding of system information messages

- initiates a cell update procedure on cell change of another UTRA cell
- Use C-RNTI assigned in the current cell as the UE identity on common transport channels unless when a new cell is selected
- transmits uplink control signals and small data packets on the RACH.
- In FDD mode, transmits uplink control signals and larger data packets on CPCH when resources are allocated to cell and UE is assigned use of those CPCH resources.
- In TDD mode, transmits signalling messages or user data in the uplink and/or the downlink using USCH and/or DSCH when resources are allocated to the cell and the UE is assigned use of those USCH/DSCH resources
- In TDDmode, transmits measurement reports in the uplink using USCH when resources are allocated to it in order to trigger a handover procedure in the UTRAN

Furthermore, in FDD mode, the UE may use the FAUSCH to trigger the allocation of a new DCH by UTRAN. Further rate adaptation can be done via the DCCH of the new DCH.

9.3.2.1 Transition from CELL_FACH to CELL_DCH state

A transition occurs, when a dedicated physical channel is established via explicit signalling.

In FDD mode, the state transition may also be done by using the FAUSCH.

9.3.2.2 Transition from CELL_FACH to CELL_PCH state

Since the UE performs continuous reception of FACH in this state, it should be moved to the CELL_PCH state if the data service has not been active for a while. When an inactivity timer (T_{in}) expires, the UE state is changed to CELL_PCH in order to decrease power consumption. Also, when coming from CELL_PCH state, and after the cell update procedure has been performed, the UE state is changed back to CELL_PCH state if neither the UE nor the network has any data to transmit.

In FDD mode, when coming from the CELL_FACH substate, the FAUSCH is still available in the CELL_PCH state after the transition.

9.3.2.3 Transition from CELL_FACH to Idle Mode

The release of the RRC connection moves the UE to the idle mode.

9.3.2.4 Transition from CELL_FACH to URA_PCH State

To perform the URA update procedure, UE is moved temporarily from URA_PCH to CELL_FACH state. After the URA update is completed, UE state is changed back to URA_PCH.

If FAUSCH is intended to be used in URA_PCH State, a FAUSCH transport channel needs to be allocated for the intended cells in the URA prior to this transition.

9.3.2.5 Radio Resource Allocation Tasks (CELL_FACH)

In the CELL_FACH state the UE will monitor an FACH. It is enabled to transmit uplink control signals and it may be able to transmit small data packets on the RACH. The network can assign the UE transport channel parameters (e.g. transport format sets) in advance, to be used when a DCH is used. When the physical channel for DCH is assigned, the UE state is changed to CELL_DCH and the assigned TFS for the DCH can be used.

The UE shall use the common physical channel and transport channel configuration according to the system information when no UE dedicated physical channel or transport channel channel configuration has been assigned.

For the uplink data transmission, the UE reports the observed traffic volume to the network in order for the network to re-evaluate the current allocation of resources. This report contains e.g. the amount of data to be transmitted or the buffer status in the UE.

When there is either user or control data to transmit, a selection procedure determines whether the data should be transmitted on a common transport channel, or if a transition to CELL_DCH should be executed. The selection is dynamic and depends on e.g. traffic parameters (amount of data, packet burst frequency).

In FDD mode, the UTRAN can assign CPCH resources to the UE in CELL_FACH state. When CPCH resources are assigned, the UE will continue to monitor FACHs. The UE may use the RACH to transmit uplink control signals and small data packets. The UE also may choose to transmit data packets, larger than those carried on the RACH, on the CPCH channel. The UE selects either the RACH or one of the CPCH channels to make maximum use of the capacity available on that channel.

In FDD mode, the UE provides the UTRAN with CPCH measurement data which includes data queue depth (current size of data buffers), average access time for each CPCH channel used, and average traffic volume on each CPCH channel used. With these measurands, the UTRAN can reallocate network resources on a periodic basis. The UTRAN allocates CPCH Sets to each cell and assigns UEs to one of the cells CPCH Sets. The UEs can dynamically access the CPCH resources without further UTRAN control.

In the TDD mode, the UTRAN can assign USCH / DSCH resources to the UE in CELL_FACH state. When USCH / DSCH resources are assigned, the UE will continue to monitor FACHs, depending on the UE capability. The UE may use the USCH / DSCH to transmit signalling messages or user data in the uplink and / or the downlink using USCH and / or DSCH when resources are allocated to cell and UE is assigned use of those USCH / DSCH.

For the uplink data transmission on USCH the UE reports to the network the traffic volume (current size of RLC data buffers), The UTRAN can use these measurement reports to re-evaluate the current allocation of the USCH / DSCH resources.

9.3.2.6 RRC Connection mobility tasks (CELL_FACH)

In this state the location of the UE is known on cell level. A cell update procedure is used to report to the UTRAN, when the UE selects a new cell to observe the common downlink channels of a new cell. Downlink data transmission on the FACH can be started without prior paging.

In CELL_FACH state an CELL_FACH cell set comparable to the active set of a dedicated channel in SHO is maintained both in the UE and in the network. The CELL_FACH cell set represents a list of cells which have the potential to serve the UE from radio signal strength perspective. The UE performs measurements and reporting for the CELL_FACH cell set using the same procedures as in CELL_DCH state. The thresholds required for triggering a measurement report may be different from those in CELL_DCH state.

The CELL_FACH cell set information is used by the network to decide whether the user data can be routed directly via a cell to a specific UE or soft handover would be required when resuming the DCH operation. In addition, the CELL_FACH cell set information provides the means for the network to evaluate potential interference conditions and select a suitable amount of capacity when moving the UE in the DCH active substate, for both uplink and downlink data transfer.

The UE monitors the broadcast channel and system information on BCCH of its own and neighbour cells and from this the need for the updating of cell location is identified.

The UE shall perform cell reselection and upon selecting a new UTRA cell, it shall initiate a cell update procedure.

Upon selecting a new cell belonging to another radio access system than UTRA, the UE shall enter idle mode and make an access to that system according to its specifications.

9.3.2.7 UE Measurements (CELL_FACH)

The UE shall perform measurements and transmit measurement reports according to the measurement control information.

The UE shall use the measurement control information according to the system information when no UE dedicated measurement control information has been assigned.

9.3.2.8 Transfer and update of system information (CELL_FACH)

The UE shall read the BCH to acquire valid system information. For each acquisition, the UE may need different combinations of system information broadcast on BCH. The scheduling on the broadcast channel is done in such way that the UE knows when the requested information can be found.

When the system information is modified, the scheduling information is updated to reflect the changes in system information transmitted on BCH. The new scheduling information is broadcast on FACH in order to inform UEs about the changes. If the changes are applicable for the UE, the modified system information is read on BCH.

9.3.3 CELL_PCH state

The CELL_PCH state is characterised by:

- No dedicated physical channel is allocated to the UE
- The UE uses DRX for monitoring a PCH via an allocated PICH.
- No uplink activity is possible.
- The position of the UE is known by UTRAN on cell level according to the cell where the UE last made a cell update in CELL_FACH state.

In this state the UE performs the following actions:

- monitor the paging occasions according to the DRX cycle and receive paging information on the PCH
- listens to the BCH transport channel of the serving cell for the decoding of system information messages
- initiates a cell update procedure on cell change.

The DCCH logical channel cannot be used in this sub. If the network wants to initiate any activity, it needs to make a paging request on the PCCH logical channel in the known cell to initiate any downlink activity.

9.3.3.1 Transition from CELL_PCH to URA_PCH State

The only overhead in keeping a UE in the CELL_PCH state is the potential possibility of cell updating, when the UE moves to other cells.

To reduce this overhead, the UE is moved to the URA_PCH State when low activity is observed. This can be controlled with an inactivity timer, and optionally, with a counter, which counts the number of cell updates. When the number of cell updates has exceeded certain limits (a network parameter), then UTRAN orders the UE to the URA_PCH State. This transition is made via the CELL_FACH state.

[Editor's note: If the coverage area of FAUSCH is expanded from one cell to several cells in the URA in relation to the execution of this transition, the new FAUSCH allocation information for each new cell in the URA needs to be exchanged either in the CELL_FACH or a CELL_DCH-based state prior to a transition from CELL_PCH to URA_PCH state. For proper operation, this shouldn't be observed as increased activity.]

9.3.3.2 Transition from CELL_PCH to CELL_FACH state

The UE is transferred to >CELL_FACH state either by a command (packet paging) from UTRAN or through any uplink access.

In FDD mode, if a valid FAUSCH transport channel is allocated for the current cell, the UE changes to CELL_FACH state as soon as it uses the FAUSCH to allocate a DCH.

9.3.3.3 Radio Resource Allocation Tasks (CELL_PCH)

In CELL_PCH state no resources have been granted for data transmission. For this purpose, a transition to another state has to be executed.

The UE may use Discontinuous Reception (DRX) in order to reduce power consumption. When DRX is used the UE needs only to receive at one paging occasion per DRX cycle. The UE may be instructed to use a specific DRX cycle length by the network. The UE shall determine its paging occasions in the same way as for Idle Mode, see TS 25.304.

9.3.3.4 RRC Connection mobility tasks (CELL_PCH)

In the CELL_PCH state, the UE mobility is performed through cell reselection procedures, which may differ from the one defined in TS 25.304.

The UE shall perform cell reselection and upon selecting a new UTRA cell, it shall move to CELL_FACH state and initiate a cell update procedure in the new cell. After the cell update procedure has been performed, the UE shall change its state back to CELL_PCH state if neither the UE nor the network has any more data to transmit.

Upon selecting a new cell belonging to another radio access system than UTRA, the UE shall enter idle mode and make an access to that system according to its specifications.

9.3.3.5 UE Measurements (CELL_PCH)

The UE shall perform measurements and transmit measurement reports according to the measurement control information.

The UE shall use the measurement control information according to the system information when no UE dedicated measurement control information has been assigned.

9.3.3.6 Transfer and update of system information (CELL_PCH)

The UE shall read the BCH to acquire valid system information. For each acquisition, the UE may need different combinations of system information broadcast on BCH. The scheduling on the broadcast channel is done in such way that the UE knows when the requested information can be found.

9.3.4 URA_PCH State

The URA_PCH state is characterised by:

- Neither an uplink nor a downlink dedicated physical channel is allocated to the UE
- The UE uses DRX for monitoring a PCH via an allocated PICH.
- No uplink activity is possible
- The location of the UE is known on UTRAN Registration area level according to the URA assigned to the UE during the last URA update in CELL_FACH state.

In this state the UE performs the following actions:

- monitor the paging occasions according to the DRX cycle and receive paging information on the PCH
- listens to the BCH transport channel of the serving cell for the decoding of system information messages
- initiates a URA updating procedure on URA change.

The DCCH logical channel cannot be used in this state. If the network wants to initiate any activity, it needs to make a paging request on the PCCH logical channel within the URA where the location of the UE is known. If the UE needs to transmit anything to the network, it goes to the CELL_FACH state. In addition, the UE can also use the FAUSCH for requesting a DCH in the whole URA or parts of it, if the UE has been allocated - on entering the connected mode or via explicit signalling later on - a FAUSCH channel for the cell, which the UE is currently camping on.

The transition to URA_PCH State can be controlled with an inactivity timer, and optionally, with a counter which counts the number of cell updates. When the number of cell updates has exceeded certain limits (a network parameter), then the UE changes to the URA_PCH State.

URA updating is initiated by the UE which, upon the detection of the Registration area, sends the network the Registration area update information on the RACH of the new cell.

9.3.4.1 Transition from URA_PCH State to Cell_FACH State

Any activity causes the UE to be transferred to CELL_FACH State. Uplink access is performed by either RACH or FAUSCH, if a FAUSCH transport channel for the current cell has been allocated.

Note that the release of an RRC connection is not possible in the URA_PCH State. The UE will first move to Cell_FACH State to perform the release signalling.

9.3.4.2 Radio Resource Allocation Tasks (URA_PCH)

In URAPCH State no resources have been granted for data transmission. For this purpose, a transition to CellFACH State has to be executed.

The UE may use Discontinuous Reception (DRX) in order to reduce power consumption. When DRX is used the UE needs only to receive at one paging occasion per DRX cycle. The UE may be instructed to use a specific DRX cycle length by the network. The UE shall determine its paging occasions in the same way as for Idle Mode, see TS 25.304.

9.3.4.3 RRC Connection mobility tasks (URA_PCH)

In URA_PCH State the location of a UE is known on UTRAN Registration area level.

In this state, the UE mobility is performed through URA reselection procedures, which may differ from the definitions in S2.04. The UE shall perform cell reselection and upon selecting a new UTRA cell belonging to an URA which does not match the URA used by the UE, the UE shall move to CELL_FACH state and initiates a URA update towards the network. After the URA update procedure has been performed, the UE shall change its state back to URA_PCH state if neither the UE nor the network has any more data to transmit.

Upon selecting a new cell belonging to another radio access system than UTRA, the UE shall enter idle mode and make an access to that system according to its specifications (FFS).

9.3.4.4 UE Measurements

The UE shall perform measurements and transmit measurement reports according to the measurement control information.

The UE shall use the measurement control information according to the system information when no UE dedicated measurement control information has been assigned.

9.3.4.5 Transfer and update of system information (URA_PCH)

The same mechanisms to transfer and update system information as for state CELL_PCH are applicable for UEs in URA_PCH state, see section [Error! Reference source not found.9](#).

9.4 Inter-system handover with PSTN/ISDN domain services

When using PSTN / ISDN domain services, UTRAN is using an Inter-System Handover Procedure and GSM is using a Handover procedure for the transition from UTRAN Connected Mode to GSM Connected Mode.

9.5 Inter-system handover with IP domain services

When using IP domain services, the UE initiates cell reselection from a GSM/GPRS cell to a UTRAN cell and then uses the RRC Connection Establishment procedure for the transition to UTRAN Connected mode.

When the RRC Connection is established from Idle Mode (GPRS Packet Idle Mode) the RRC CONNECTION REQUEST message contains an indication, that UTRAN needs to continue an already established GPRS UE context from the CN. This indication allows UTRAN to e.g. prioritize the RRC CONNECTION REQUEST from the UE.

In UTRAN connected mode UTRAN is using UE or network initiated cell reselection to change from a UTRAN cell to a GSM/GPRS cell. If the cell reselection was successful the UE enters Idle Mode (GPRS Packet Idle Mode). The UE sends a packet channel request from Idle Mode (GPRS Packet Idle mode) to establish a Temporary Block flow and enter GPRS Packet Transfer Mode. In the GPRS Packet Transfer Mode the UE sends a RA Update request message. The RA Update Request message sent from the UE contains an indication that GSM/GPRS need to continue an already established UTRAN UE context from the CN. This means that the RA Update request is always sent for the transition from UTRAN Connected Mode to GSM/GPRS regardless if the RA is changed or not.

[Note: The reason for using RA update instead of a new message is to reduce the impact on the existing GSM/GPRS specification.]

9.6 Inter-system handover with simultaneous IP and PSTN/ISDN domain services

[Note: This is an initial assumption that needs to be seen by SMG2 and requiring checking by SMG2, when the work on this item has progressed.]

9.6.1 Inter-system handover UTRAN to GSM / BSS

For a UE in CELL_DCH state using both PSTN / ISDN and IP Domain services the Inter-system handover procedure is based on measurement reports from the UE but initiated from UTRAN.

The UE performs the Inter-system handover from UTRAN Connected Mode to GSM Connected Mode first. When the UE has sent handover complete message to GSM / BSS the UE initiates a temporary block flow towards GPRS and sends a RA update request.

If the Inter-system handover from UTRAN Connected Mode to GSM Connected Mode was successful the handover is considered as successful regardless if the UE was able to establish a temporary block flow or not towards GPRS.

In case of Inter-system handover failure the UE has the possibility to go back to UTRAN Connected Mode and re-establish the connection in the state it originated from without attempting to establish a temporary block flow. If the UE

has the option to try to establish a temporary block flow towards GSM / GPRS after Inter-system handover failure is FFS.

9.6.2 Inter-system handover GSM / BSS to UTRAN

For a UE in GSM Connected Mode using both PSTN / ISDN and IP domain services the Inter-system handover procedure is based on measurement reports from the UE but initiated from GSM / BSS.

The UE performs the Inter-system handover from GSM Connected Mode to UTRAN Connected Mode.

In UTRAN Connected Mode both services are established in parallel.

If the Inter-System handover from GSM Connected mode to UTRAN Connected Mode was successful the handover is considered as successful.

In case of Inter-system handover failure the UE has the possibility to go back to GSM Connected Mode and re-establish the connection in the state it originated from.

10 Message and information element functional definition and content

The function of each Radio Resource Control message together with message contents in the form of a list of information elements is defined in subclause 10.1.

Functional definitions of the information elements are then described in subclause 10.2. Information elements are marked as either M- mandatory, O - Optional or C -conditional (see [Table 1](#) [Table 4](#)).

Abbreviation	Meaning
M	IE's marked as Mandatory (M) will always be included in the message.
O	IE's marked as Optional (O) may or may not be included in the message.
C	IE's marked as Conditional (C) will be included in a message only if the condition is satisfied otherwise the IE is not included.

Table 1) meaning of abbreviations used in RRC messages and information elements

10.1 Radio Resource Control messages

10.1.1 RRC Connection Mobility Messages

10.1.1.1 ACTIVE SET UPDATE (FDD only)

<Functional description of this message to be included here>

RLC-SAP: AM

Logical channel: DCCH

Direction: UTRAN → UE

Information Element	Presence	Range	IE type and reference	Semantics description
Message Type	M			
UE information elements				
U-RNTI	O			New U-RNTI
Activation time	O			
CN information elements				
PLMN identity	O			(Note3)
CN related information		0 to <MaxNoC Ndomains >		CN related information to be provided for each CN domain
CN domain identity	O			(Note3)
NAS system info	O			(Note3)

Phy CH information elements				
Maximum allowed UL TX power	O			
Radio link addition information		0 to <MaxAddRLcount>		Radio link addition information required for each RL to add
Primary CCPCH info	M			Note 1
SSDT cell identity	C - ifSSDT			
Downlink DPCH info	M			
Radio link removal information		0 to <MaxDelRLcount>		Radio link removal information required for each RL to remove
Primary CCPCH info	M			Note 1
Gated Transmission Control Info	O			FFS, Note 2
SSDT indicator	O			

Condition	Explanation
<i>IfSSDT</i>	This IE is only sent when SSDT is being used and a new radio link is added

Range bound	Explanation
<i>MaxAddRLcount</i>	Maximum number of radio links which can be added
<i>MaxDelRLcount</i>	Maximum number of radio links which can be removed/deleted

Note 1: If it is assumed that primary CCPCH downlink scrambling code is always allocated with sufficient reuse distances, primary CCPCH downlink scrambling code will be enough for designating the different radio links.

Note 2: The activation time should be present when the Gated Transmission control info is present in this message. Note 3: Necessity of PLMN is FFS and for CN domain identity and NAS system information, the confirmation in SA WG2 is needed.

10.1.1.2 ACTIVE SET UPDATE COMPLETE (FDD only)

<Functional description of this message to be included here>

RLC-SAP: AM

Logical channel: DCCH

Direction: UE→UTRAN

Information Element	Presence	Range	IE type and reference	Semantics description
Message Type	M			
Phy CH information elements				
SSDT indicator	O			

10.1.1.3 ACTIVE SET UPDATE FAILURE (FDD only)

<Functional description of this message to be included here>

RLC-SAP: AM

Logical channel: DCCH

Direction: UE→UTRAN

Information Element	Presence	Range	IE type and reference	Semantics description
Message Type	M			
UE information elements				
Failure cause	M			

10.1.1.4 CELL UPDATE

This message is used by the UE to initiate a cell update procedure.

RLC-SAP: TM

Logical channel: CCCH

Direction: UE→UTRAN

Information Element	Presence	Range	IE type and reference	Semantics description
Message Type	M			
UE information elements				
U-RNTI	M			
Cell update cause	M			
AM_RLC error indication	O			Indicates AM_RLC unrecoverable error occurred on c-plane in the UE
Measurement information elements				
Measurement identity number				Intra-frequency measurement related report
Measured results				

10.1.1.5 CELL UPDATE CONFIRM (FDD only)

This message confirms the cell update procedure and can be used to reallocate new RNTI information for the UE valid in the new cell.

RLC-SAP: UM

Logical channel: DCCH

Direction: UTRAN→UE

Information Element	Presence	Range	IE type and reference	Semantics description
Message Type	M			
UE information elements				
U-RNTI	O			New U-RNTI
C-RNTI	O			New C-RNTI

RLC re-configuration indicator	C-AM_RLC_recon			
UTRAN DRX cycle length	O			
DRX Indicator	O			
UTRAN mobility information elements				
URA identifier	O			
CN information elements				
PLMN identity	O			(Note1,2)
CN related information		0 to <MaxNoCNdomains>		CN related information to be provided for each CN domain
CN domain identity	O			(Note1,2)
NAS system info	O			(Note1,2)
Physical CH information elements (FFS Note 5)				
Frequency info	O (FFS)			
Uplink radio resources				
Uplink DPCH power control info	O (FFS)			
CHOICE channel requirement				
Uplink DPCH info	O (FFS)			
PRACH info (for RACH)	O (FFS)			
CHOICE mode				
FDD				
PRACH info (for FAUSCH)	O (FFS)			
Downlink radio resources				
DL information per radio link		0 to <maxNoRLs>		
Primary CCPCH info	O (FFS)			
Downlink DPCH info	O (FFS)			
Secondary CCPCH info	O (FFS)			
				Note 3
CHOICE mode				
FDD				
SSDT indicator	O (FFS)			
CPCCH SET Info	O (FFS)			UL/DL radio resource for CPCCH control (Note4)
Gated Transmission Control info	O (FFS)			
Default DPCH Offset Value	O (FFS)			

CHOICE channel requirement	Condition under which the given channel requirement is chosen
Uplink DPCH info	
PRACH info (for RACH)	
PRACH info (for FAUSCH)	

Range Bound	Explanation
<i>MaxNoRLs</i>	Maximum number of radio links
<i>MaxNoCN domains</i>	Maximum number of CN domains

Condition	Explanation
<i>AM_RLC_recon</i>	This IE is only sent when the UTRAN requests AM RLC re-configuration

[Note1: It depends on the length of these information whether this message can be used to notify these information to UE.]

[Note2: Necessity of PLMN is FFS and for CN domain identity and NAS system information, the confirmation in SA WG2 is needed.]

Note 3: It is assumed that the DL timeslot configuration is the same for all radio links, whether or not macro-diversity is supported for TDD.

Note 4: How to map UL and DL radio resource in the message is FFS.

Note 5: The inclusion of any physical channel information elements requires further study

10.1.1.6 HANDOVER COMMAND

<Functional description of this message to be included here>

RLC-SAP: AM

Logical channel: DCCH

Direction: UTRAN → UE

Information Element	Presence	Range	IE type and reference	Semantics description
Message Type	M			
UE information elements				
U-RNTI	O			New U-RNTI
CHOICE mode				
TDD				
C-RNTI				
CN information elements	O			
PLMN identity	O			(Note2)
CN related information		0 to <MaxNoC Ndomains >		CN related information to be provided for each CN domain
CN domain identity	O			(Note2)
NAS system info	O			(Note2)
Phy CH information elements				
Frequency info	M			
Maximum allowed UL TX power	O			
Uplink radio resources				
UL DPCH power control info	M			
UL DPCH info	M			
Downlink radio resources				
Link specific information		1 to <MaxHoRL count>		Provide information for each DL radio link. (Note 1)
Primary CCPCH info	M			
DL DPCH info	M			
CHOICE mode				
FDD				
SSDT indicator	O			
SSDT Cell ID	C ifSSDT			FFS
TDD				
Uplink Timing Advance	O			

Condition	Explanation
<i>IfSSDT</i>	This IE is only sent when SSDT is used

Range Bound	Explanation
<i>MaxHoRLcount</i>	Maximum number of DL radio links which can be

	established on handover
--	-------------------------

Note1: The possibility to request the establishment of several radio links simultaneously with this message is FFS.

Note2: Necessity of PLMN is FFS and for CN domain identity and NAS system information, the confirmation in SA WG2 is needed.

10.1.1.7 HANDOVER COMPLETE

<Functional description of this message to be included here>

RLC-SAP: AM

Logical channel: DCCH

Direction: UE → UTRAN

Information Element	Presence	Range	IE type and reference	Semantics description
Message Type	M			
Phy CH information elements				
CHOICE <i>mode</i>				
TDD				
SSDT indicator	O			

10.1.1.8 HANDOVER FAILURE

<Functional description of this message to be included here>

RLC-SAP: AM

Logical channel: DCCH

Direction: UE→UTRAN

Information Element	Presence	Range	IE type and reference	Semantics description
Message Type	M			
UE information elements				
Failure cause	M			

10.1.1.9 INTER-SYSTEM HANDOVER COMMAND

This message is used for handover from UMTS to another system e.g. GSM. One or several messages from the other system can be included in the Inter-System message information element in this message. These messages are structured and coded according to that systems specification.

RLC-SAP: AM

Logical channel: DCCH

Direction: UTRAN→UE

Information Element	Presence	Range	IE type and reference	Semantics description
Message Type	M			
UE information elements				
Activation time	O			
Other information Elements				
Inter-System message	M			

10.1.1.10 INTER-SYSTEM HANDOVER FAILURE

This message is sent on the RRC connection used before the Inter-System Handover was executed. The message indicates that the UE has failed to seize the new channel in the other system.

RLC-SAP: AM

Logical channel: DCCH

Direction: UE→UTRAN

Information Element	Presence	Range	IE type and reference	Semantics description
Message Type	M			
UE information elements				
Inter-System handover failure cause	O			FFS
Other Information Elements				
Inter-System message	O			

10.1.1.11 URA UPDATE

This message is used by the UE to initiate a URA update procedure.

RLC-SAP: TM

Logical channel: CCCH

Direction: UE→UTRAN

Information Element	Presence	Range	IE type and reference	Semantics description
Message Type	M			
UE information elements				
U-RNTI	M			
URA update cause	M			

10.1.1.12 URA UPDATE CONFIRM

This message confirms the URA update procedure and can be used to reallocate new RNTI information for the UE valid after the URA update.

RLC-SAP: UM

Logical channel: CCCH or DCCH

Direction: UTRAN→UE

Information Element	Presence	Range	IE type and reference	Semantics description
Message Type	M			
UE information elements				
U-RNTI	C-CCCH			
U-RNTI	O			New U-RNTI
C-RNTI	O			New C-RNTI
UTRAN DRX cycle length	O			
DRX Indicator	O			
UTRAN mobility information elements				
URA identifier	O			
CN information elements				
PLMN identity	O			(Note1,2)
CN related information		0 to <MaxNoC Ndomains >		CN related information to be provided for each CN domain
CN domain identity	O			(Note1,2)
NAS system info	O			(Note1,2)

Range Bound	Explanation
<i>MaxNoCN domains</i>	Maximum number of CN domains

Condition	Explanation
<i>CCCH</i>	This IE is only sent when CCCH is used

[Note1: It depends on the length of these information whether this message can be used to notify these information to UE.]

[Note2: Necessity of PLMN is FFS and for CN domain identity and NAS system information, the confirmation in SA WG2 is needed.]

10.1.1.13 RNTI REALLOCATION

<Functional description of this message to be included here>

RLC-SAP: AM or UM

Logical channel: DCCH

Direction: UTRAN→UE

Information Element	Presence	Range	IE type and reference	Semantics description
Message Type	M			
UE information elements				
U-RNTI	O			New U-RNTI
C-RNTI	O			New C-RNTI
CN information elements				
PLMN identity	O			(Note1,2)
CN related information		0 to <MaxNoC Ndomains >		CN related information to be provided for each CN domain
CN domain identity	O			(Note1,2)
NAS system info	O			(Note1,2)

Range Bound	Explanation
<i>MaxNoCN domains</i>	Maximum number of CN domains

[Note1: It depends on the length of these information whether this message can be used to notify these information to UE.]

[Note2: Necessity of PLMN is FFS and for CN domain identity and NAS system information, the confirmation in SA WG2 is needed.]

10.1.1.14 RNTI REALLOCATION COMPLETE

This message is used to confirm the new RNTI information for the UE.
 RLC-SAP: AMt.b.d.
 Logical channel: DCCH
 Direction: UE→UTRAN

Information Element	Presence	Range	IE type and reference	Semantics description
Message Type	M			

10.1.2 Measurement Messages

10.1.2.1 MEASUREMENT CONTROL

<Functional description of this message to be included here>
 RLC-SAP: AM
 Logical channel: DCCH
 Direction: UTRAN→UE

Information Element	Presence	Range	IE type and reference	Semantics description
Message Type	M			
Measurement Information elements				
Measurement Identity Number	M			
Measurement Command	M			
Measurement Type	O			
Measurement Reporting Mode	O			
CHOICE Measurement				
Intra-frequency				
Intra-frequency cell info				Measurement object
Intra-frequency measurement quantity	C event trigger			
Intra-frequency measurement reporting quantity	O			Note 1
CHOICE report criteria				
Intra-frequency measurement reporting criteria				
Periodical reporting				
Inter-frequency				
Inter-frequency cell info				Measurement object
Inter-frequency measurement quantity	C event trigger			
Inter-frequency measurement reporting quantity	O			Note 1
Inter-frequency set Update				
CHOICE report criteria				
Intra-frequency measurement reporting criteria				
Inter-frequency measurement reporting criteria				
Periodical reporting				
Inter-system				
Inter-system cell info				Measurement object
Inter-system measurement quantity	C event trigger			
Inter-system measurement reporting quantity	O			Note 1
CHOICE report criteria				
Inter-system measurement reporting criteria				
Periodical reporting				
Traffic Volume				
Traffic volume measurement Object				
Traffic volume measurement quantity	C event trigger			
Traffic volume measurement reporting quantity	O			Note 1
CHOICE report criteria				
Traffic volume measurement reporting criteria				
Periodical reporting				
Quality				
Quality measurement Object				
Quality measurement quantity	C event trigger			
Quality measurement reporting quantity	O			Note 1
CHOICE report criteria				
Quality measurement				

reporting criteria				
Periodical reporting				
UE internal				
UE internal measurement quantity	C event trigger			
UE internal measurement reporting quantity	O			Note 1
CHOICE report criteria				
UE internal measurement reporting criteria				
Periodical reporting				

Condition	Explanation
<i>event trigger</i>	This element is only included in the message which is sent in event trigger reporting mode.

CHOICE Measurement	Condition under which the given Measurement is chosen
intra-frequency	if measurement type=Intra-frequency measurement
inter-frequency	if measurement type=Inter-frequency measurement
inter-system	if measurement type=Intra-system measurement
traffic volume	if measurement type=traffic volume measurement
Quality	if measurement type=Quality measurement
UE internal	if measurement type=UE internal measurement
CHOICE reporting criteria	Condition under which the given reporting criteria is chosen
***** measurement reporting criteria	Chosen when event triggering is required
periodical reporting	Chosen when periodical reporting is required

Note 1: It is FFS whether it is necessary to separate the reporting quantity for each type.

Note 2: The network may order the UE to report other measurements when UE internal measurements are reported

10.1.2.2 MEASUREMENT CONTROL FAILURE

<Functional description of this message to be included here>

RLC-SAP: AM

Logical channel: DCCH

Direction: UE→UTRAN

Information Element	Presence	Range	IE type and reference	Semantics description
Message Type	M			
UE information elements				
Failure cause	M			

10.1.2.3 MEASUREMENT REPORT

<Functional description of this message to be included here>

RLC-SAP: AM or UM

Logical channel: DCCH

Direction: UE→UTRAN

Information Element	Presence	Range	IE type and reference	Semantics description
Message Type	M			
Measurement Information Elements				
Measurement report information		1 to <maxMeasRepCount>		Send Measurement Report information for each measurement report in the message (Note 1)
Measurement identity number	M			
Measured Results	C MR required			
CHOICE event result	C event trigger			Note 1,2
Intra-frequency measurement event results				
Inter-frequency measurement event results				
Inter-system measurement event results				
Traffic volume measurement event results				
Quality measurement event results				

Condition	Explanation
<i>event trigger</i>	This element is only included in the message which is sent in event trigger reporting mode.
<i>MR required</i>	This information element is included by the sender only if indicated optionally by Reporting Quantity in Measurement Control

Range Bound	Explanation
<i>MaxMeasRepCount</i>	Maximum number of Measurement reports in a message

CHOICE event result	Condition under which the given event result is chosen
intra-frequency measurement event results	
inter-frequency measurement event results	
inter-system measurement event results	
traffic volume measurement event results	
Quality measurement event results	

Note 1: Whether it is possible to send multiple measurement results that are identified by different measurement identity numbers in the same Measurement Report is FFS. An alternative solution is to allow only one measurement identity number per Measurement Report and concatenate different Measurement Reports in the RLC layer instead.

Note 2: If it is possible to send many measurement results that are identified by different events in the same Measurement Report is FFS.

10.1.3 Paging Messages

10.1.3.1 PAGING TYPE 1

This message is used to send information on the paging channel. One or several UEs, in idle or connected mode, can be paged in one message, which also can contain other information.

RLC-SAP: TM

Logical channel: PCCH

Direction: UTRAN → UE

Information Element	Presence	Range	IE type and reference	Semantics description
Message Type	M			
UE Information elements				
Paging record		1 to <Page Count>		
Other information elements				
BCCH modification info	O			FFS

Range Bound	Explanation
<i>Page Count</i>	Number of UE's paged in the Paging Type 1 message

10.1.3.2 PAGING TYPE 2

This message is used to page an UE in connected mode, when using the DCCH for CN originated paging.

RLC-SAP: AM

Logical channel: DCCH

Direction: UTRAN → UE

Information Element	Presence	Range	IE type and reference	Semantics description
Message Type	M			
CN Information elements				
CN domain identity	M			
Paging Record Type Identifier	M		Enumerated (IMSI, TMSI/P-TMSI)	
UE Information elements				
Paging cause	M			

10.1.4 RRC Connection Establishment and maintenance messages

10.1.4.1 RRC CONNECTION RE-ESTABLISHMENT

<Functional description of this message to be included here>

RLC-SAP: UM

Logical channel: DCCH

Direction: UTRAN → UE

Information Element	Presence	Range	IE type and reference	Semantics description
Message Type	M			
UE information elements				
U-RNTI	O			Only in case of SRNC relocation
C-RNTI	O			Only if assigned to a common transport channel
Activation time	O			
CN information elements				
PLMN identity	O			(Note1)
CN related information		0 to <MaxNoC Ndomains >		CN related information to be provided for each CN domain
CN domain identity	O			(Note1)
NAS system info	O			(Note1)

RB information elements				
RB information		0 to <MaxRBcount>		RB information is sent for each RB affected by this message
RB identity	M			
RLC info	O			FFS
RB multiplexing info	M			
Transport Channel Information Elements				
TFCS	O			For uplink TFCSs
TFCS	O			For downlink TFCSs
CHOICE <i>mode</i>				
TDD				
TFCS Identity	O			Uplink TFCS
TFCS Identity	O			Downlink TFCS
TFC subset	O			For TFCSs in uplink
Uplink transport channels				
Transport channel identity		0 to <MaxDelTrCH>		
Reconfigured TrCH information		0 to <MaxReconAddTrCH>		
Transport channel identity	M			
TFS	M			
DRAC information	C DRAC	1 to <MaxReconAddTrCH>		
Dynamic Control				
Transmission time validity				
Time duration before retry				
Silent period duration before release				
Downlink transport channels				
Transport channel identity		0 to <MaxDelTrCH>		
Reconfigured TrCH information		0 to <MaxReconAddTrCH>		
Transport channel identity	M			
TFS	M			
PhyCH information elements				
Frequency info	O			
Maximum allowed UL TX power	O			
Uplink DPCH power control info	O			
Uplink radio resource information				
CHOICE channel requirement	O			
Uplink DPDCH info				
PRACH info				
Downlink radio resource information				
Downlink information		0 to <MaxRlcount>		Send downlink information for each radio link to be set-up
Primary CCPCH info				
Downlink DPDCH info				
Secondary CCPCH info				
CHOICE <i>mode</i>				
FDD				
SSDT indicator	O			FFS
SSDT Cell ID	C ifSSDT			FFS
CPCH SET info	O			UL/DL radio resource for

Information Element	Presence	Range	IE type and reference	Semantics description
Message Type	M			

10.1.4.3 RRC CONNECTION RE-ESTABLISHMENT REQUEST

<Functional description of this message to be included here>

RLC-SAP: TM

Logical channel: CCCH

Direction: UE → UTRAN

Information Element	Presence	Range	IE type and reference	Semantics description
Message Type	M			
UE information elements				
U-RNTI	M			
Measurement information elements				
Measurement information		1 to <MeasRep Count>		Send Measurement information for each measurement report in the message
Measurement identity number	M			Refers to system information. Note 1
Measured results	M			

Note 1: The necessity and usage of Measurement identity number in this message is FFS.

Range Bound	Explanation
<i>MeasRepCount</i>	Number of measurement reports in the message

10.1.4.4 RRC CONNECTION RELEASE

<Functional description of this message to be included here>

RLC-SAP: UM

Logical channel: DCCH

Direction: UTRAN→UE

Information Element	Presence	Range	IE type and reference	Semantics description
Message Type	M			
UE information elements				
Release cause	M			
Number of RRC Message Transmissions	M			

10.1.4.5 RRC CONNECTION RELEASE COMPLETE

<Functional description of this message to be included here>

RLC-SAP: AM or UM

Logical channel: DCCH

Direction: UE → UTRAN

Information Element	Presence	Range	IE type and reference	Semantics description
Message Type	M			

10.1.4.6 RRC CONNECTION REQUEST

RRC Connection Request is the first message transmitted by the UE when setting up an RRC Connection to the network.

RLC-SAP: TM

Logical channel: CCCH

Direction: UE → UTRAN

Information Element	Presence	Range	IE type and reference	Semantics description
Message Type	M			
UE information elements				
Initial UE identity	M			
Establishment cause	M			
Initial UE capability	O			Necessity is FFS
Measurement information elements				
Measurement information		1 to <MeasRep Count>		Send Measurement information for each measurement report in the message
Measurement identity number	M			Refers to system information. Note 1
Measured results	M			

Note 1: The necessity and usage of Measurement identity number in this message is FFS.

Range Bound	Explanation
<i>MeasRepCoun</i>	Number of measurement reports in the message

10.1.4.7 RRC CONNECTION SETUP

This message is used by the network to accept the establishment of an RRC connection for an UE, including assignment of signalling link information, transport channel information and optionally physical channel information.

RLC-SAP: UM

Logical channel: CCCH

Direction: UTRAN → UE

Information Element	Presence	Range	IE type and reference	Semantics description
Message Type	M			
UE information elements				
Initial UE identity	M			
U-RNTI	M			
C-RNTI	O			Only if assigned to a common transport channel
Activation time	O			
UTRAN DRX cycle length	O			
DRX Indicator	O			
RB information elements				
RB identity	M			Indicates the signalling link
Signalling link type	M			
RB mapping info	M			For the signalling link
TrCH information elements				
TFCS	O			Uplink TFCS
TFCS	O			Downlink TFCS
CHOICE mode				
TDD				
TFCS Identity	O			Uplink TFCS
TFCS Identity	O			Downlink TFCS
TFC subset	O			
Uplink transport channel information		0 to <MaxULTrCHCount>		Send transport channel information for each new Uplink transport channel
Transport channel identity	M			
TFS	M			
Downlink transport channel information		0 to <MaxDLTrCHCount>		Send transport channel information for each new downlink transport channel
Transport channel identity	M			
TFS	M			
Transparent mode signalling info	C if TM_DCH	0 or 1		
PhyCH information elements				
Frequency info	O			
Maximum allowed UL TX power	O			
Uplink DPCH power control info	O			
Uplink radio resource information				
CHOICE channel requirement	O			
Uplink DPCH info				
PRACH info (for RACH)				
Downlink radio resource information				
Downlink DPCH power control info	O			
CHOICE mode				
FDD				
Downlink DPCH compressed mode info	O			
Downlink information		0 to <MaxRLcount>		Send downlink information for each radio link to be set-up
Primary CCPCH info				
Downlink DPCH info				
Secondary CCPCH info				
CHOICE mode				
FDD				

SSDT indicator	O			FFS
SSDT Cell ID	C ifSSDT			FFS
CPCH SET Info	O			UL/DL radio resource for CPCH control (Note2)
Gated Transmission Control info	O, FFS			Note 3
Default DPCH Offset Value	O			
TDD				
Uplink Timing Advance	O			

Condition	Explanation
<i>IfSSDT</i>	This IE is sent only when SSDT is to be used
<i>IfTM_DCH</i>	This information is only sent if a DCH carrying transparent mode DCCH information is used, e.g. to send transport format combination commands.

Range Bound	Explanation
<i>MaxULTrCHCoun</i>	Maximum number of new uplink transport channels
<i>MaxDLTrCHCount</i>	Maximum number of new downlink transport channels
<i>MaxRLcoun</i>	Maximum number of radio links to be set up

CHOICE <i>channel requirement</i>	Condition under which the given <i>channel requirement</i> is chosen
Uplink DPCH info	
PRACH info	

Note 2: How to map UL and DL radio resource in the message is FFS.

Note 3: The activation time should be present when the Gated Transmission control info is present in this message.

10.1.4.8 RRC CONNECTION SETUP COMPLETE

This message confirms the establishment of the RRC Connection by the UE.

RLC-SAP: AM

Logical channel: DCCH

Direction: UE → UTRAN

Information Element	Presence	Range	IE type and reference	Semantics description
Message Type	M			
Phy CH information elements				
CHOICE <i>mode</i>				
FDD				
SSDT indicator	O			FFS

10.1.4.9 RRC CONNECTION REJECT

This message is transmitted by the network when the requested RRC connection cannot be accepted.

RLC-SAP: UM

Logical channel: CCCH

Direction: UTRAN → UE

Information Element	Presence	Range	IE type and reference	Semantics description
Message Type	M			
UE information elements				
Initial UE identity	M			
Rejection cause	M			
Wait time	O			

10.1.5 Radio Bearer control messages

10.1.5.1 PHYSICAL CHANNEL RECONFIGURATION

This message is used by UTRAN to assign, replace or release a set of physical channels used by a UE.

RLC-SAP: AM or UM

Logical channel: DCCH

Direction: UTRAN → UE

Information Element	Presence	Range	IE type and reference	Semantics description
Message Type	M			
UE Information elements				
Activation time	O			
C-RNTI	C - RACH/FACH			
UTRAN DRX cycle length	O			
DRX Indicator	O			
Physical Channel information elements				
Frequency info	O			
Maximum allowed UL TX power	O			
Uplink DPCH power control info	O			
Uplink radio resource information				
CHOICE channel requirement	O			
Uplink DPCH info				
PRACH Info (for RACH)				
CHOICE mode				
FDD				
PRACH info (for FAUSCH)				
Downlink radio resource information				
Downlink DPCH power control info	O			
CHOICE mode				
FDD				
Downlink DPCH compressed mode info	O			
Downlink information		0 to <Max RLcount>		Send downlink information for each radio link
Primary CCPCH info				
Downlink DPCH info				
Secondary CCPCH info				For FACH
Secondary CCPCH info				For PCH
CHOICE mode				
TDD				
Secondary CCPCH info				For PICH
CHOICE mode				
FDD				
SSTD indicator	O			FFS
SSTD Cell ID	C ifSSTD			FFS
CPCH SET Info	O			UL/DL radio resource for CPCH control (Note2)
Default DPCH Offset Value	O			
TDD				
Uplink Timing Advance	O			

Condition	Explanation
<i>IfSSTD</i>	This IE is only sent when SSTD is used and when a new DCH is being activated
<i>RACH/FACH</i>	This information element is only included in the sent message when using RACH/FACH

Range Bound	Explanation
<i>MaxRLcount</i>	Maximum number of radio links to be set up
CHOICE channel requirement	Condition under which the given channel requirement is chosen
Uplink DPCH info	
PRACH info (for FAUSCH)	
PRACH info (for RACH)	

Note 2: How to map UL and DL radio resource in the message is FFS.

10.1.5.2 PHYSICAL CHANNEL RECONFIGURATION COMPLETE

This message is sent from the UE when a physical channel reconfiguration has been done.

RLC-SAP: AM

Logical channel: DCCH

Direction: UE → UTRAN

Information Element	Presence	Range	IE type and reference	Semantics description
Message Type	M			
Phy CH information elements				
CHOICE <i>mode</i>				
FDD				
SSDT indicator	O			Necessity is FFS

10.1.5.3 PHYSICAL CHANNEL RECONFIGURATION FAILURE

<Functional description of this message to be included here>

RLC-SAP: AM

Logical channel: DCCH

Direction: UE→UTRAN

Information Element	Presence	Range	IE type and reference	Semantics description
Message Type	M			
UE information elements				
Failure cause	M			

10.1.5.4 RADIO BEARER RECONFIGURATION

This message is sent from UTRAN to reconfigure parameters related to a change of QoS. This procedure can also change the multiplexing of MAC, reconfigure transport channels and physical channels.

RLC-SAP: AM or UM

Logical channel: DCCH

Direction: UTRAN → UE

Information Element	Presence	Range	IE type and reference	Semantics description
Message Type	M			
UE Information elements				
Activation time	O			
C-RNTI	C - RACH/FACH			
UTRAN DRX cycle length	O			
DRX Indicator	O			
RB information elements				
RB information		0 to <MaxRBcount>		RB information is sent for each RB affected by this message
RB identity	M			
RLC info	O			FFS
RB mapping info	O			
RB suspend/resume	O			Not applicable to the signalling bearer.
Transport Channel Information Elements				
TFCS	O			for uplink TFCS
TFCS	O			for downlink TFCS
CHOICE mode				
TDD				
TFCS Identity	O			Uplink TFCS
TFCS Identity	O			Downlink TFCS
TFC subset	O			for TFCSs in uplink
Uplink transport channels				
Transport channel identity		0 to <MaxDelTrCH>		
Reconfigured TrCH information		0 to <MaxReconAddTrCH>		
Transport channel identity	M			
TFS	M			
DRAC information	C DRAC	1 to <MaxReconAddTrCH>		
Dynamic Control				
Transmission time validity				
Time duration before retry				
Silent period duration before release				
Downlink transport channels				
Transport channel identity		0 to <MaxDelTrCH>		
Reconfigured TrCH information		0 to <MaxReconAddTrCH>		
Transport channel identity	M			
TFS	M			
Physical Channel information elements				
Frequency info	O			
Maximum allowed UL TX power	O			
Uplink DPCH power control info	O			
Uplink radio resource information	O			
CHOICE channel requirement	O			

Uplink DPCH info				
PRACH info (for RACH)				
CHOICE <i>mode</i>				
FDD				
PRACH info (for FAUSCH)				
Downlink radio resource information				
Downlink DPCH power control info	O			
Downlink DPCH compressed mode info	O			
Downlink information		0 to <Max RLcount>		Send downlink information for each radio link
Primary CCPCH info				
Downlink DPCH info				
Secondary CCPCH info				
CHOICE <i>mode</i>				
FDD				
SSDT indicator	O			FFS
CPCH SET Info	O			UL/DL radio resource for CPCH control (Note2)
Gated Transmission Control info	O			FFS, Note 3
Default DPCH Offset Value	O			
TDD				
Uplink Timing Advance	O			

Condition	Explanation
<i>RACH/FACH</i>	This information element is only sent when using RACH/FACH
<i>DRAC</i>	These information elements are only sent for transport channels which use the DRAC procedure

Range Bound	Explanation
<i>MaxRLcount</i>	Maximum number of radio links
<i>MaxRBcount</i>	Maximum number of RBs to be reconfigured
<i>MaxDelTrCHcount</i>	Maximum number of Transport Channels to be removed
<i>MaxReconAddTrCH</i>	Maximum number of transport channels to add and reconfigure

CHOICE <i>channel requirement</i>	Condition under which the given <i>channel requirement</i> is chosen
Uplink DPCH info	
PRACH info (for RACH)	
PRACH info (for FAUSCH)	

Note 2: How to map UL and DL radio resource in the message is FFS.

Note 3: The activation time should be present when the Gated Transmission control info is present in this message.

10.1.5.5 RADIO BEARER RECONFIGURATION COMPLETE

This message is sent from the UE when a RB and signalling link reconfiguration has been done.

RLC-SAP: AM

Logical channel: DCCH

Direction: UE → UTRAN

Information Element	Presence	Range	IE type and reference	Semantics description
Message Type	M			
Phy CH information elements				
CHOICE <i>mode</i>				
FDD				
SSDT indicator	O			FFS

10.1.5.6 RADIO BEARER RECONFIGURATION FAILURE

<Functional description of this message to be included here>

RLC-SAP: AM

Logical channel: DCCH

Direction: UE→UTRAN

Information Element	Presence	Range	IE type and reference	Semantics description
Message Type	M			
UE information elements				
Failure cause	M			

10.1.5.7 RADIO BEARER RELEASE

<Functional description of this message to be included here>

RLC-SAP: AM or UM

Logical channel: DCCH

Direction: UTRAN → UE

Information Element	Presence	Range	IE type and reference	Semantics description
Message Type	M			
UE Information elements				
Activation time	O			
C-RNTI	C - RACH/FACH			
UTRAN DRX cycle length	O			
DRX Indicator	O			
RB information elements				
RB identity		1 to <MaxRelR Bcount>		
RB identity		0 to <MaxOther RBcount>		
RB mapping info	O			
Transport Channel Information Elements				
TFCS	O			for uplink TFCS
TFCS	O			for downlink TFCS
CHOICE mode				
TDD				
TFCS Identity	O			Uplink TFCS
TFCS Identity	O			Downlink TFCS
TFC subset	O			for DCHs in uplink
Uplink transport channels				
Transport channel identity		0 to <MaxDelTr CH>		
Reconfigured TrCH information		0 to <MaxReconAddFFST rCH>		
Transport channel identity	M			
TFS	M			
DRAC information	C DRAC	1 to <MaxReconAddFFST rCH>		
Dynamic Control				
Transmission time validity				
Time duration before retry				
Silent period duration before release				
Downlink transport channels				
Transport channel identity		0 to <MaxDelTr CH>		
Reconfigured TrCH information		0 to <MaxReconAddTrCH >		Editor : this limit should probably also be MaxReconAddFFSTrCH
Transport channel identity	M			
TFS	M			
Physical Channel information elements				
Frequency info	O			
Maximum allowed UL TX power	O			
Uplink DPCH power control info	O			
Uplink radio resource information	O			
CHOICE mode				
FDD				
Gated Transmission Control	O, FFS			Note 3

info				
CPCH SET Info	O			UL/DL radio resource for CPCH control (Note2)
TDD				
Uplink Timing Advance	O			
CHOICE channel requirement	O			
Uplink DPCH info				
CHOICE <i>mode</i>				
FDD				
PRACH info (for FAUSCH)				
PRACH info (for RACH)				
Downlink radio resource information				
Downlink information		0 to <Max RLcount>		Send downlink information for each radio link to be set-up
Primary CCPCH info				
Downlink DPCH info				
Secondary CCPCH info				

Condition	Explanation
<i>RACH/FACH</i>	This information element is only sent when using RACH/FACH
<i>DRAC</i>	These information elements are only sent for transport channels which use the DRAC procedure

Range Bound	Explanation
<i>MaxRLcount</i>	Maximum number of radio links
<i>MaxDelRBcount</i>	Maximum number of RBs to be released/deleted
<i>MaxOtherRBcount</i>	Maximum number of Other RBs (ie RB's not being released) affected by the procedure
<i>MaxDelTrCHcount</i>	Maximum number of Transport CHannels to be removed
<i>MaxReconAddFFSTrCH</i>	Maximum number of transport channels to add (FFS) and reconfigure

CHOICE <i>channel requirement</i>	Condition under which the given <i>channel requirement</i> is chosen
Uplink DPCH info	
PRACH Info (for RACH)	
PRACH info (for FAUSCH)	

Note 2: How to map UL and DL radio resource in the message is FFS.

Note 3: The activation time should be present when the Gated Transmission control info is present in this message.

10.1.5.8 RADIO BEARER RELEASE COMPLETE

<Functional description of this message to be included here>

RLC-SAP: AM

Logical channel: DCCH

Direction: UE → UTRAN

Information Element	Presence	Range	IE type and reference	Semantics description
Message Type	M			

10.1.5.9 RADIO BEARER RELEASE FAILURE

<Functional description of this message to be included here>

RLC-SAP: AM

Logical channel: DCCH

Direction: UE→UTRAN

Information Element	Presence	Range	IE type and reference	Semantics description
Message Type	M			
UE information elements				
Failure cause	M			

10.1.5.10 RADIO BEARER SETUP

<Functional description of this message to be included here>

RLC-SAP: AM or UM

Logical channel: DCCH

Direction: UTRAN → UE

Information Element	Presence	Range	IE type and reference	Semantics description
Message Type	M			
CN information elements				
NAS binding info	M			
CN domain identity				
UE Information elements				
Activation time	O			
C-RNTI	C – RACH/FAC H			
UTRAN DRX cycle length	O			
DRX Indicator	O			
RB information elements				
Information for new RBs		1 to <MaxNew RBcount>		
RB identity	M			
RLC info	M			
RB mapping info	M			
Information for other RB's affected by this message		0 to <MaxOther RBcount>		
RB identity	M			
RB mapping info	M			
Transport Channel Information Elements				
TFCS	O			for uplink TFCS
TFCS	O			for downlink TFCS
CHOICE <i>mode</i>				
TDD				
TFCS Identity	O			Uplink TFCS
TFCS Identity	O			Downlink TFCS
TFC subset	O			for DCHs in uplink
Uplink transport channels				
Transport channel identity		0 to <MaxDelTr CH>		editor should this be FFS also?
Reconfigured TrCH information		0 to <MaxReco nAddTrCH >		
Transport channel identity	M			
TFS	M			
DRAC information	C DRAC	1 to <MaxReco nAddTrCH >		
Dynamic Control				
Transmission time validity				
Time duration before retry				
Silent period duration before release				
Downlink transport channels				
Transport channel identity		0 to <MaxDelTr CH>		FFS
Reconfigured TrCH information		0 to <MaxReco nAddTrCH >		
Transport channel identity	M			
TFS	M			
Physical Channel information elements				
Frequency info	O			
Maximum allowed UL TX power	O			

Uplink DPCH power control info	O			
Uplink radio resource information	O			
CHOICE <i>mode</i>				
FDD				
CPCH SET Info	O			UL/DL radio resource for CPCH control (Note2)
CHOICE channel requirement	O			
Uplink DPCH info				
PRACH Info (for RACH)				
CHOICE <i>mode</i>				
FDD				
PRACH info (for FAUSCH)				
Downlink radio resource information				
Downlink DPCH power control info	O			
CHOICE <i>mode</i>				
FDD				
Downlink DPCH compressed mode info	O			
Downlink information		0 to <Max RLcount>		Send downlink information for each radio link
Primary CCPCH info				
Downlink DPCH info				
Secondary CCPCH info				
CHOICE <i>mode</i>				
FDD				
SSDT indicator	O			FFS
SSDT Cell ID	C ifSSDT			FFS
Gated Transmission Control info	O			FFS
Default DPCH Offset Value	O			
TDD				
Uplink Timing Advance	O			

Condition	Explanation
<i>RACH/FACH</i>	This information element is only sent when using RACH/FACH
<i>IfSSDT</i>	This IE is only sent when SSDT is used and when a new DCH is being activated

Range Bound	Explanation
<i>MaxRLcount</i>	Maximum number of radio links
<i>MaxDelTrCHcount</i>	Maximum number of Transport CHannels to be removed
<i>MaxReconAddcount</i>	Maximum number of Transport CHannels reconfigured or added
<i>MaxNewRBcount</i>	Maximum number of RBs that could be setup with this message
<i>MaxOtherRBcount</i>	Maximum number of Other RBs (ie RB's not being released) affected by the procedure

CHOICE channel requirement	Condition under which the given channel requirement is chosen
Uplink DPCH info	
PRACH info (for FAUSCH)	
PRACH info (for RACH)	

Note 2: How to map UL and DL radio resource in the message is FFS.

Note 3: The activation time should be present when the Gated Transmission control info is present in this message.

10.1.5.11 RADIO BEARER SETUP COMPLETE

<Functional description of this message to be included here>

RLC-SAP: AM

Logical channel: DCCH

Direction: UE → UTRAN

Information Element	Presence	Range	IE type and reference	Semantics description
Message Type	M			
Phy CH information elements				
CHOICE <i>mode</i>				
FDD				
SSDT indicator	O			FFS

10.1.5.12 RADIO BEARER SETUP FAILURE

<Functional description of this message to be included here>

RLC-SAP: AM

Logical channel: DCCH

Direction: UE→UTRAN

Information Element	Presence	Range	IE type and reference	Semantics description
Message Type	M			
UE information elements				
Failure cause	M			

10.1.5.13 TRANSPORT CHANNEL RECONFIGURATION

This message is used by UTRAN to configure the transport channel of a UE. This also includes a possible reconfiguration of physical channels. The message can also be used to assign a TFC subset and reconfigure physical channel.

RLC-SAP: AM or UM

Logical channel: DCCH

Direction: UTRAN → UE

Information Element	Presence	Range	IE type and reference	Semantics description
Message Type	M			
UE Information elements				
Activation time	O			
C-RNTI	C - RACH/FACH			
UTRAN DRX cycle length	O			
DRX Indicator	O			
Transport Channel Information Elements				
TFCS	O			for uplink TFCS
TFCS	O			for downlink TFCS
CHOICE <i>mode</i>				
TDD				
TFCS Identity	O			Uplink TFCS
TFCS Identity	O			Downlink TFCS
TFC subset	O			for DCHs in uplink
Uplink transport channels				
Reconfigured TrCH information		0 to <MaxReconTrCH>		
Transport channel identity				
TFS				
DRAC information	C DRAC	1 to <MaxReconTrCHDRAC>		
Dynamic Control				
Transmission time validity				
Time duration before retry				
Silent period duration before release				
Downlink transport channels				
Reconfigured TrCH information		0 to <MaxReconTrCH>		
Transport channel identity				
TFS				
Physical Channel information elements				
Frequency info	O			
Maximum allowed UL TX power	O			
Uplink DPCH power control info	O			
Uplink radio resource information				
CPCH SET Info	O			UL/DL radio resource for CPCH control (Note2)
CHOICE channel requirement	O			
Uplink DPCH info				
CHOICE <i>mode</i>				
FDD				
PRACH info (for FAUSCH)				
PRACH info (for RACH)				
	O			
Downlink radio resource information				
Downlink DPCH power control info	O			
CHOICE <i>mode</i>				
FDD				
Downlink DPCH	O			

compressed mode info				
Downlink information		0 to <Max RLcount>		Send downlink information for each radio link
Primary CCPCH info				
Downlink DPCH info				
Secondary CCPCH info				
CHOICE <i>mode</i>				
FDD				
SSDT indicator	O			FFS
SSDT Cell ID	C ifSSDT			FFS
Gated Transmission Control info	O			FFS, Note 3
Default DPCH Offset Value	O			
TDD				
Uplink Timing Advance	O			

Condition	Explanation
<i>!SSDT</i>	This IE is only sent when SSDT is used and when a new DCH is being activated
<i>RACH/FACH</i>	This information element is only sent when using RACH/FACH

Range Bound	Explanation
<i>MaxRLcount</i>	Maximum number of radio links to be set up
<i>MaxReconcount</i>	Maximum number of Transport CHannels reconfigured
<i>MaxReconTrCHDRAC</i>	Maximum number of Transport CHannels which are controlled by DRAC and which are reconfigured

CHOICE <i>channel requirement</i>	Condition under which the given <i>channel requirement</i> is chosen
Uplink DPCH info	
PRACH info (for RACH)	
PRACH info (for FAUSCH)	

Note 2: How to map UL and DL radio resource in the message is FFS.

Note 3: The activation time should be present when the Gated Transmission control info is present in this message.

10.1.5.14 TRANSPORT CHANNEL RECONFIGURATION COMPLETE

This message is sent from the UE when a transport channel reconfiguration has been done.

RLC-SAP: AM

Logical channel: DCCH

Direction: UE → UTRAN

Information Element	Presence	Range	IE type and reference	Semantics description
Message Type	M			
Phy CH information elements				
CHOICE <i>mode</i>				
FDD				
SSDT indicator	O			FFS

Note: The usage of this message for indicating the cell the UE will select in the DCH->RACH/FACH case, is FFS.

10.1.5.15 TRANSPORT CHANNEL RECONFIGURATION FAILURE

<Functional description of this message to be included here>

RLC-SAP: AM

Logical channel: DCCH

Direction: UE→UTRAN

Information Element	Presence	Range	IE type and reference	Semantics description
Message Type	M			
UE information elements				
Failure cause	M			

10.1.5.16 TRANSPORT FORMAT COMBINATION CONTROL

<Functional description of this message to be included here>

RLC-SAP: TM, AM or UM

Logical channel: DCCH

Direction: UTRAN→UE

Information Element	Presence	Range	IE type and reference	Semantics description
Message Type	C-notTM			
TrCH information elements				
TFC subset	M			For uplink TFCS

Condition	Explanation
<i>NotTM</i>	The message type is not included when transmitting the message on the transparent mode signalling DCCH

10.1.5.17 DOWNLINK OUTER LOOP CONTROL

<Functional description of this message to be included here>

RLC-SAP: AM or UM

Logical channel: DCCH

Direction: UTRAN→UE

Information Element	Presence	Range	IE type and reference	Semantics description
Message Type	M			
PhyCH information elements				
Downlink Outer Loop Control	M			Indicates whether the UE is allowed or not to increase its Eb/No target value above its current value

10.1.5.18 PHYSICAL SHARED CHANNEL ALLOCATION (TDD only)

This message is used by UTRAN to assign physical resources to USCH/DSCH transport channels in TDD, for temporary usage by the UE.

RLC-SAP: TM or AM

Logical channel: SHCCH

Direction: UTRAN → UE

Information Element	Presence	Range	IE type and reference	Semantics description
Message Type	M			
UE Information elements				
C-RNTI	M			
PUSCH allocation pending	O			
Transport Channel information elements				
TFCS identity	O			
Physical Channel information elements				
PUSCH power control info	O			
Uplink timing advance info	O			
PUSCH info	O			
PDSCH info	O			

10.1.5.19 PUSCH CAPACITY REQUEST (TDD only)

This message is used by the UE for request of PUSCH resources to the UTRAN.

RLC-SAP: t.b.d.

Logical channel: SHCCH

Direction: UE → UTRAN

Information Element	Presence	Range	IE type and reference	Semantics description
Message Type	M			
UE information elements				
C-RNTI	M			
Measurement information elements				
Traffic amount information		1 to <RABCount>		Send traffic amount information for each Radio Access Bearer in the message
RB ID	M			
RLC buffer payload	M			
Measurement information		0 to <MeasRepCount>		Send Measurement information for each measurement report in the message
Measurement identity number	M			Refers to system information
Measured results	M			

Range Bound	Explanation
<i>RABCount</i>	Number of traffic amount informations in the message
<i>MeasRepCount</i>	Number of measurement reports in the message

10.1.6 System Information Messages

10.1.6.1 SYSTEM INFORMATION

Information Element	Presence	Range	IE type and reference	Semantics description
Message type	C channel			
CHOICE				
> First SIB Segment			First SIB Segment	
> Subsequent SIB Segment			Subsequent SIB Segment	
> Parts				
>> Last SIB Segment	C number		Last SIB Segment	
>> Complete SIB	C number	0..indefinite	Complete SIB	

Condition	Explanation
Channel	The message type is mandatory on the FACH, and absent on the BCH
Number	If 'parts' is present, then <ul style="list-style-type: none"> a) There shall be 0 or 1 'Last SIB segment; c) 'Parts' shall not be empty.

10.1.6.2 First SIB Segment

This segment type is used to transfer the first segment of a segmented system information block.

RLC_SAP: TM

Logical channel: BCCH

Direction: UTRAN -> UE

Information Element	Presence	Range	IE type and reference	Semantics description
Segment Type	M			
Other information elements				
SIB type	M			
SEG_COUNT	M			
SIB data	M			

10.1.6.3 Subsequent SIB Segment

This segment type is used to transfer a subsequent segment of a segmented system information block.

RLC_SAP: TM

Logical channel: BCCH

Direction: UTRAN -> UE

Information Element	Presence	Range	IE type and reference	Semantics description
Segment type	M			
Other information elements				
SIB type	M			
Segment index	M			
SIB data	M			

10.1.6.4 Last SIB Segment

This segment type is used to transfer the last segment of a segmented system information block.

RLC_SAP: TM

Logical channel: BCCH

Direction: UTRAN -> UE

Information Element	Presence	Range	IE type and reference	Semantics description
Segment type	M			
Other information elements				
SIB type	M			
Segment index	M			
SIB data	M			

10.1.6.4 Complete SIB

This segment type is used to transfer a non-segmented system information block.

RLC_SAP: TM

Logical channel: BCCH

Direction: UTRAN -> UE

Information Element	Presence	Range	IE type and reference	Semantics description
Segment type	M			
Other information elements				
SIB type	M			
SIB content	M			

10.1.6.4 System Information Blocks

10.1.6.4.1 SIB Content

SIB Segments are the result of the segmentation of a 'SIB Content' IE. The SIB content IE is developed hereafter :

Information Element	Presence	Range	IE type and reference	Semantics description
CHOICE SIB type	M			
> Master information block				
> System information block type 1				
> System information block type 2				
> System information block type 3				
> System information block type 4				
> System information block type 5				
> System information block type 6				
> System information block type 7				
> System information block type 8				
> System information block type 9				
> System information block type 10				
> System information block type 11				
> System information block type 12				
SI Padding	C filling			

Condition	Explanation
SIB Type	The common value of the 'SIB type' field in the segment(s).
filling	It is an acceptable constraint that, when the last segment of the SIB is the last IE of a System Information message, the padding is constrained to be such that it fills the transport block.

10.1.6.4.2 Master Information Block

Area scope: Cell

UE mode: Idle mode and connected mode

Information Element	Presence	Range	IE type and reference	Semantics description
Other information elements				
Value tag	M			
References to other system information blocks		1 .. <maxSysInfoBlockcount>		
Scheduling information	M			
CN information elements				
CN Type	M			
PLMN Identity	M			

Condition	Explanation

<i>Blocktype</i>	The presence of this IE depends on the value of the preceding SIB type. This IE is mandatory if the specification of the SIB of that SIB type includes as first IE a Value tag IE.
------------------	--

Range Bound	Explanation
<i>MaxSysInfoBlockcount</i>	Maximum number of references to other system information blocks.

10.1.6.4.3 System Information Block type 1

The system information block type 1 contains NAS system information as well as UE timers and counters to be used in idle mode.

Area scope: PLMN

UE mode: idle mode

Information Element	Presence	Range	IE type and reference	Semantics description
Other information elements				
Value tag	M			
CN information elements				
CN information		1 to <maxCNdo mains>		Send CN information for each CN domain.
CN domain identity	M			
NAS system information	M			
CN DRX cycle length	M			
UE information				
UE Timers and counters	M			<i>Note: Only timers and counters used in idle mode</i>
Capability update requirement	O			

Range Bound	Explanation
<i>MaxCNdomains</i>	Maximum number of CN domains

10.1.6.4.4 System Information Block type 2

The system information block type 2 contains the URA identity and information for periodic cell and URA update. It also includes the UE timers and counters to be used in connected mode.

Area scope: PLMN

UE mode: connected mode

Information Element	Presence	Range	IE type and reference	Semantics description
Other information elements				
Value tag	M			
UTRAN mobility information elements				
URA identity		1 ..<maxURAccount>		
Information for periodic cell and URA update	M			
UE information				
UE Timers and counters	M			<i>Note: Only timers and counters used in connected mode</i>

Range Bound	Explanation
<i>MaxURAccount</i>	Maximum number of URA's in a cell

10.1.6.4.5 System Information Block type 3

The system information block type 3 contains parameters for cell selection and re-selection. The block may also contain scheduling information for other system information blocks.

Area scope: cell

UE mode: idle mode (and connected mode)

Information Element	Presence	Range	IE type and reference	Semantics description
Other information elements				
Value tag	M			
References to other system information blocks		0 .. <maxSysInfoBlockcount>		
Scheduling information	M			
UTRAN mobility information elements				
Cell identity	M			The necessity and usage of cell identity is FFS.
Cell selection and re-selection info	M			

Range Bound	Explanation
<i>MaxSysInfoBlockcount</i>	Maximum number of references to other system information blocks.

10.1.6.4.6 System Information Block type 4

The system information block type 4 contains parameters for cell selection and re-selection to be used in connected mode. The block may also contain scheduling information for other system information blocks. The block is optional. When not sent, the MS shall apply in connected mode the values of the similar information indicated for idle mode.

Area scope: cell

UE mode: connected mode

Information Element	Presence	Range	IE type and reference	Semantics description
Other information elements				
Value tag	M			
References to other system information blocks		0 .. <maxSysInfoBlockcount>		
Scheduling information	M			
UTRAN mobility information elements				
Cell identity	M			The necessity and usage of cell identity is FFS.
Cell selection and re-selection info	M			

Range Bound	Explanation
<i>MaxSysInfoBlockcount</i>	Maximum number of references to other system information blocks.

10.1.6.4.7 System Information Block type 5

The system information block type 5 contains parameters for the configuration of the common physical channels in the cell. The block may also contain scheduling information for other system information blocks.

Area scope: cell

UE mode: idle mode (and connected mode)

Information Element	Presence	Range	IE type and reference	Semantics description
Other information elements				
Value tag	M			
References to other system information blocks		0 .. <maxSysInfoBlockcount>		
Scheduling information	M			
PhyCH information elements				
Frequency info	O			
Maximum allowed UL TX power	O			
CHOICE mode				
TDD				
PSCH Time slot				
FDD				
Secondary CPICH info	O			Note 2
Primary CCPCH info	O			Note 1
PRACH information		1 .. <maxPRACHcount>		
PRACH info	M			
TFS	M			
CHOICE mode				
FDD				
AICH info	M			
TDD				
ASC info	O			
Secondary CCPCH information		1 .. <maxSCCPCHcount>		
Secondary CCPCH info	M			
TFCS	M			For FACHs and PCH
FACH information		1 .. <maxFACHcount>		
TFS				For each FACHs and PCH
PICH info	C-Pich			
Maximum allowed UL TX power				
UE Information elements				
UTRAN_DRX_cycle length				

Note 1: DL scrambling code of the Primary CCPCH is the same as the one for Primary CPICH.

Note 2: This parameter is needed in case of using adaptive array antenna.

Condition	Explanation
<i>Pich</i>	PICH info is present only when PCH is multiplexed on Secondary CCPCH
Range Bound	
<i>MaxPRACHcount</i>	Maximum number of PRACHs
<i>MaxSCCPCHcount</i>	Maximum number of secondary CCPCHs
<i>MaxFACHcount</i>	Maximum number of FACH's mapped onto secondary CCPCH's
<i>MaxPCHcount</i>	Maximum number of PCH's mapped onto secondary CCPCH's
<i>MaxSysInfoBlockcount</i>	Maximum number of references to other system information blocks.

10.1.6.4.8 System Information Block type 6

The system information block type 6 contains parameters for the configuration of the common physical channels to be used in connected mode. The block may also contain scheduling information for other system information blocks. The block is optional. When not sent, the MS shall apply in connected mode the values of the similar information indicated for idle mode.

Area scope: cell

UE mode: connected mode

Information Element	Presence	Range	IE type and reference	Semantics description
Other information elements				
Value tag	M			
References to other system information blocks		0 .. <maxSysInfoBlockcount>		
Scheduling information	M			
PhyCH information elements				
Frequency info	O			
Maximum allowed UL TX power	O			
Primary CCPCH info	O			Note 1
CHOICE mode				
FDD				
Secondary CPICH info	O			Note 2
PRACH information		0 .. <maxPRACHcount>		
PRACH info	M			
TFS	M			
CHOICE mode				
FDD				
AICH info	M			
Secondary CCPCH information		0 .. <maxSCCPCHcount>		
Secondary CCPCH info	M			
TFCS	M			For FACHs and PCH
FACH information		1 .. <maxFACHcount>		
TFS				For each FACHs and PCH
PICH info	C-Pich			
Maximum allowed UL TX power				
UE Information elements				
UTRAN_DRX_cycle length				

Note 1: DL scrambling code of the Primary CCPCH is the same as the one for Primary CPICH.

Note 2: This parameter is needed in case of using adaptive array antenna.

Condition	Explanation
<i>Pich</i>	PICH info is present only when PCH is multiplexed on Secondary CCPCH

Range Bound	Explanation
<i>MaxPRACHcount</i>	Maximum number of PRACH's
<i>MaxSCCPCHcount</i>	Maximum number of secondary CCPCH's
<i>MaxFACHcount</i>	Maximum number of FACH's mapped onto secondary CCPCH's
<i>MaxPCHcount</i>	Maximum number of PCH's mapped onto secondary CCPCH's
<i>MaxSysInfoBlockcount</i>	Maximum number of references to other system information blocks.

10.1.6.4.9 System Information Block type 7

The system information block type 7 contains the uplink access control parameters and the PRACH power control information to be used in the cell.

Area scope: cell

UE mode: idle mode (and connected mode)

Information Element	Presence	Range	IE type and reference	Semantics description
Other information elements				
Expiration time	M			The expiration time specifies how long time the values of the information elements included this system information block are valid.
UE information				
Uplink access control info	M			
PhyCH information elements				
PRACH information		1 .. <maxPRA CHcount>		
PRACH power control inform.	M			

Range Bound	Explanation
<i>MaxPRACHcount</i>	Maximum number of PRACH's

10.1.6.4.10 System Information Block type 8

The system information block type 8 contains the uplink access control parameters and the PRACH power control information to be used in connected mode. The block is optional. When not sent, the MS shall apply in connected mode the values of the similar information indicated for idle mode.

Area scope: cell

UE mode: connected mode

Information Element	Presence	Range	IE type and reference	Semantics description
Other information elements				
Expiration time	M			The expiration time specifies how long time the values of the information elements included in this system information block are valid.
UE information				
Uplink access control info	O			
PhyCH information elements				
PRACH information		0 to <maxPRA CHcount>		
PRACH power control inform.	M			

Range Bound	Explanation
<i>MaxPRACHcount</i>	Maximum number of PRACH's

10.1.6.4.11 System Information Block type 9 (FDD)

The system information block type 9 contains CPCH information to be used in the cell.

Area scope: cell

UE mode: connected mode

Information Element	Presence	Range	IE type and reference	Semantics description
Other information elements				
Expiration time	M			The expiration time specifies how long time the values of the information elements included in this system information block are valid.
UE information				
CPCH parameters	M			
PhyCH information elements				
CPCH SET info	M			
CPCH set persistency value	M			

10.1.6.4.11 System Information Block type 10 (FDD)

The system information block type 10 contains information to be used by UEs having their DCH controlled by a DRAC procedure. The system information block is optional. That the SIB is not sent indicates that the DRAC procedures do not apply in this cell.

Area scope: cell

UE mode: connected mode

Information Element	Presence	Range	IE type and reference	Semantics description
Other information elements				
Expiration time	M			The expiration time specifies how long time the values of the information elements included in this system information block are valid.
UE information				
DRAC information		1 .. <maxDRA Cclasses>		DRAC information is sent for each class of terminal
Transmission probability	M			
Maximum bit rate	M			

Range Bound	Explanation
<i>MaxDRACclasses</i>	Maximum number of UE classes which would require different DRAC parameters

10.1.6.4.12 System Information Block type 11

The system information block type 11 contains measurement control information to be used in idle mode. The values may also be used in connected mode if the corresponding IEs are not specified in System information block type 12. The block may also contain scheduling information for other system information blocks.

Area scope: cell

UE mode: idle mode (and connected mode)

Information Element	Presence	Range	IE type and reference	Semantics description
Other information elements				
Value tag	M			
References to other system information blocks		0 .. <maxSysInfoBlockcount>		
Scheduling information	M			
Measurement information elements				
Measurement control information		1 .. <maxMeasurementTypecount>		
Measurement type	M			
CHOICE Measurement	C – Intrafreq			
Intra-frequency				
Intra-frequency cell info	M			
Intra-frequency Measurement quantity	M			
Intra-frequency reporting Quantity for RACH Reporting	M			
Maximum number of Reported cells on RACH	M			
Intra-frequency reporting criteria				
Intra-frequency reporting Quantity	O			
Inter-frequency	C – Interfreq			
Inter-frequency cell info	M			
Inter-frequency Measurement quantity	M			
Inter-system	C – Intersys			
Inter-system cell info	M			
Inter-system measurement Quantity	M			

Condition	Explanation
Measurement	The choice shall be consistent (same name) with the value of the 'Measurement type' IE
<i>Intersys</i>	Measurement type = Inter system measurement
<i>Interfreq</i>	Measurement type = Inter frequency measurement
<i>Intrafreq</i>	Measurement type = Intra frequency measurement
<i>Blocktype</i>	The presence of this IE depends on the definition of the system information block type.

Range Bound	Explanation
<i>MaxMeasTypeCount</i>	Maximum number of measurement types
<i>MaxSysInfoBlockcount</i>	Maximum number of references to other system information blocks.

10.1.6.4.14 System Information Block type 12

The system information block type 12 contains measurement control information to be used in connected mode.

Area scope: cell

UE mode: connected mode

Information Element	Presence	Range	IE type and reference	Semantics description
Other information elements				
Value tag	M			
References to other system information blocks		0 .. <maxSysInfoBlockcount>		
SIB type	M			
Value tag	C – Blocktype			
Scheduling information	M			
Measurement information elements				
Measurement control information		1 .. <maxMeasurementTypecount>		
Measurement Identity Number	M			
Measurement Type	M			
CHOICE Measurement				
Intra-frequency	C – Intrafreq			
Intra-frequency cell info	O			
Intra-frequency Measurement quantity	O			
Intra-frequency Reporting quantity for RACH reporting	O			
Maximum number of Reported cells on RACH	O			
Intra-frequency reporting Quantity	O			
Inter-frequency	C - Interfreq			
Inter-frequency cell Info	O			
Inter-frequency Measurement quantity	O			
Inter-system	C - Intersys			
Inter-system cell info	O			
Inter-system measurement quantity	O			
Traffic volume				
Traffic volume measurement objects	M			
Traffic volume measurement quantity	M			
UE Internal				
UE internal measurement quantity	M			

Condition	Explanation
Measurement	The choice shall be consistent (same name) with the value of the 'Measurement type' IE
<i>Intersys</i>	Measurement type = Inter system measurement
<i>Interfreq</i>	Measurement type = Inter frequency measurement
<i>Intrafreq</i>	Measurement type = Intra frequency measurement
<i>Blocktype</i>	The presence of this IE depends on the value of the preceding SIB type. This IE is mandatory if the specification of the SIB of that SIB type includes as

	first IE a Value tag IE.
Range Bound	Explanation
<i>MaxMeasTypeCount</i>	Maximum number of measurement types
<i>MaxSysInfoBlockcount</i>	Maximum number of references to other system information blocks.
Option	Default value
All optional elements	If not present, the value shall be assumed to be that indicated for in idle mode in SIB 11.

10.1.7 Other Messages

10.1.7.1 UE CAPABILITY INFORMATION

<Functional description of this message to be included here>

RLC-SAP: AM or UM

Logical channel: DCCH

Direction: UE → UTRAN

Information Element	Presence	Range	IE type and reference	Semantics description
Message Type	M			
CN information elements				
CN domain identifier	M			
NAS message	M			<u>Includes the CN capability information</u>
UE information elements				
Power control capability	M			
Code resource capability	M			
UE mode capability	M			
Transport CH support capability	O			
Ciphering capability	M			
Macro diversity capability	M			
FAUSCH usage support	O			Indicates true/false for "DCH allocation function;" "USCH capability request function."
Other information elements				
Inter-system message	O			<u>Includes inter-system classmark</u>

Note: The WG1 and WG4 discussion should be concluded before the contents of this message can be finalized.

10.1.7.2 UE CAPABILITY INFORMATION CONFIRM

<Functional description of this message to be included here>

RLC-SAP: UM

Logical channel: DCCH

Direction: UTRAN → UE

Information Element	Presence	Range	IE type and reference	Semantics description
Message Type	M			

10.1.7.3 UE CAPABILITY ENQUIRY

The UE CAPABILITY ENQUIRY is used by the UTRAN to enquire inter-system classmarks from the UE.

RLC-SAP: t.b.d.
 Logical channel: DCCH
 Direction: UTRAN → UE

Information Element	Presence	Range	IE type and reference	Semantics description
Message Type	M			
UE information elements				
System	M		Enumerated (GSM,..)	

10.1.7.4 DIRECT TRANSFER

<Functional description of this message to be included here>

RLC-SAP: AM
 Logical channel: DCCH
 Direction: both

Information Element	Presence	Range	IE type and reference	Semantics description
Message Type	M			
CN information elements				
CN domain identity	M			
NAS message	M			
Measurement information elements				
Measured results	O			

10.1.7.5 SECURITY MODE CONTROL COMMAND

RLC-SAP: AM
 Logical channel: DCCH
 Direction: UTRAN to UE

Information Element	Presence	Range	IE type and reference	Semantics description
Message Type	M			
CN Information elements				
CN domain identity	M			Indicates which cipher key is <u>Applicable</u>
RB Information elements				
Radio bearer identity		1 to <maxReco nRBs>		Radio bearer identity 0 indicates the signalling link and is always present
UE information elements				
Activation Time	M			<u>Start of the new ciphering configuration in uplink for all the radio bearers</u>

Range Bound	Explanation

<i>MaxReconRBs</i>	For each radio bearer that is reconfigured
--------------------	--

10.1.7.6 SECURITY MODE CONTROL COMPLETE

RLC-SAP: AM

Logical channel: DCCH

Direction: UE to UTRAN

Information Element	Presence	Range	IE type and reference	Semantics description
Message Type	M			
RB Information elements				
Radio bearer identity		1 to <maxReconRBs>		Radio bearer identity 0 indicates the signalling link and is always present
UE information elements				
Activation Time	M			<u>Start of the new ciphering configuration in uplink for all the radio bearers</u>

Range Bound	Explanation
<i>MaxReconRBs</i>	For each radio bearer that is reconfigured

10.2 Information element functional definitions

10.2.1 CN Information elements

10.2.1.1 CN domain identity

Points out the core network domain (e.g. IP or PSTN/ISDN CN domain).

10.2.1.2 NAS binding info

A field with non-access stratum information to bind a RB to the non-access stratum. This information is transparent to RRC.

10.2.1.3 NAS message

A non-access stratum message to be transferred transparently through UTRAN.

10.2.1.4 NAS system information

System information that belongs to the non-access stratum (e.g. LAC, RA code etc). This information is transparent to RRC.

10.2.1.5 PLMN identity

Information Element/Group name	Presence	Range	IE type and reference	Semantics description
MCC, Mobile Country Code	M			
MNC, Mobile Network Code	M			

10.2.1.6 CN DRX cycle length

Indicates the time interval between monitoring paging occasions to be used by a UE when attached to a specific Core Network.

10.2.1.7 CN Type

Information Element/Group name	Presence	Range	IE type and reference	Semantics description
CN Type	M		Enumerated (GSM-MAP, ANSI-41)	Identifies the type of core network. This IE shall be used to control the interpretation of network dependent messages and information elements in the RRC protocol.

10.2.2 UTRAN mobility Information elements

10.2.2.1 Cell identity

This information element identifies a cell unambiguously within a PLMN.

Information Element/Group name	Presence	Range	IE type and reference	Semantics description
Cell identity	M		Integer (0..268 435 455)	

10.2.2.2 Cell selection and re-selection info

Information Element/Group name	Presence	Range	IE type and reference	Semantics description
Standby allowed reception level (dBm)	M			The usage of these parameters needs clarification FFS.
Standby prohibited reception level (dBm)	M			
Threshold for Cell Re-selection (dB)	M			
Allowed reception SIR (dB)	M			
Radio link timeout				

10.2.2.3 Information for periodic cell and URA update

This information element indicates information to support mechanisms for periodical cell/URA update procedures. It is mapped on System Information message.

Information Element/Group name	Presence	Range	IE type and reference	Semantics description
T_periodical_cell_update	M		Enumerated (No updating, 1..1023)	Designate the time period between updating in minutes, or if no periodical updating should be done.
T_periodical_ura_update	M		Enumerated (No updating, 1..1023)	Designate the time period between updating in minutes, or if no periodical updating should be done.

10.2.2.4 URA identity

Gives the identity of the UTRAN Registration Area. It can be used to indicate to the UE which URA it shall use in case of overlapping URAs.

Information Element/Group name	Presence	Range	IE type and reference	Semantics description
URA identity			Enumerated (0..65 535)	

10.2.3 UE Information elements

10.2.3.1 Uplink access control info

Information Element/Group name	Presence	Range	IE type and reference	Semantics description
Access Service class	M	1 to 8		
PRACH partitioning	M			Mapping to a subset of the available access slots and signatures
Available signature Start Index			Integer(0..15)	
Available signature End Index			Integer(0..15)	
Available sub-channel Start Index			Integer(0..11)	
Available sub-channel End Index			Integer(0..11)	
Dynamic persistence level	M			FFS

PRACH partitioning:

The list of available signatures is renumbered from signature index 0 to signature index N-1, where N is the number of available signatures, starting with the lowest available signature number and continuing in sequence, in the order of increasing signature numbers.

- List of available signatures : 16 or less signatures are available.

Ex : only signatures 0, 5, 10 and 15 are available, then :

Signature 0 is : available signature index 0

Signature 5 is : available signature index 1

Signature 10 is : available signature index 2

Signature 15 is : available signature index 3

The list of available access-slot sub-channels is renumbered from access-slot sub-channel index 0 to access-slot sub-channel index M-1, where M is the number of available access-slot sub-channels, starting with the lowest available access-slot sub-channel number and continuing in sequence, in the order of increasing access-slot sub-channel numbers.

- List of available Access Slot channels : 12 or less sub-channels are available.

Ex : only sub-channels 0,1 ; 4,5 ; 8,9 are present, then :

Sub-channel 0 is : available sub-channel index 0

Sub-channel 1 is : available sub-channel index 1

Sub-channel 4 is : available sub-channel index 2

Sub-channel 5 is : available sub-channel index 3

Sub-channel 8 is : available sub-channel index 4

Sub-channel 9 is : available sub-channel index 5

One ASC has access to all the access-slot sub-channels between the Available sub-channel Start Index and the Available sub-channel End Index, and to all the signatures between the Available signature Start Index and the Available signature End Index.

<Editor's Note: The above text may eventually be moved to a more appropriate location>

10.2.3.2 C-RNTI

The cell RNTI (C-RNTI) identifies an UE having a RRC connection within a cell.

Information Element/Group name	Presence	Range	IE type and reference	Semantics description
C-RNTI			Integer(0..65535)	

10.2.3.3 U-RNTI

The U-RNTI (UTRAN Radio Network Temporary Identity) is allocated to an UE having a RRC connection and identifies the UE within UTRAN.

Information Element/Group name	Presence	Range	IE type and reference	Semantics description
SRNC identity	M		Integer(0..4095)	
S-RNTI	M		Integer(0..1048575)	

10.2.3.4 Initial UE identity

This information element identifies the UE at a request of an RRC connection.

Information Element/Group name	Presence	Range	IE type and reference	Semantics description
CHOICE UE id type	M			
IMSI			TS 24.008	
TMSI			TS 24.008	
P-TMSI			TS 24.008	
IMEI			TS 24.008	
LAI	C newLA		TS 24.008	
RAI	C newRA		TS 24.008	

CHOICE UE Id Type	Condition under which the given UE Id Type is used
IMSI	See section 8.5.1
TMSI	See section 8.5.1
P-TMSI	See section 8.5.1
IMEI	See section 8.5.1

Condition	Explanation
<i>NewLA</i>	See section 8.5.1
<i>NewRA</i>	See section 8.5.1

10.2.3.5 Activation time

Activation Time defines the CFN (Connection Frame Number) in which the operation/changes caused by the related message should be executed.

Information Element/Group name	Presence	Range	IE type and reference	Semantics description
Activation time			Integer(0..255)	

10.2.3.6 Wait time

Wait time defines the time period the UE has to wait before repeating the rejected procedure.

Information Element/Group name	Presence	Range	IE type and reference	Semantics description
Wait time			Integer(1..16)	Wait time in seconds

10.2.3.7 Paging record

Information Element/Group name	Presence	Range	IE type and reference	Semantics description
Paging originator	M		Enumerated (UTRAN, CN)	
Paging cause	C isCN			
CN domain identity	C isCN			
CHOICE CN Identity	C idleMode			
IMSI			TS 24.008	
TMSI			TS 24.008	
P-TMSI			TS 24.008	
U-RNTI	C connected Mode			

Condition	Explanation
<i>IsCN</i>	This information element is included where the page is originated from the CN.
IdleMode	This IE is included for UE not having RRC Connection.
ConnectedMode	This IE is included for UE having RRC Connection.
CHOICE CN Identity	Condition under which the given Identity is chosen
IMSI	For idle mode pages
TMSI	For idle mode pages
P-TMSI	For idle mode pages

10.2.3.8 Establishment cause

Cause for an RRC connection establishment request.

Information Element/Group name	Presence	Range	IE type and reference	Semantics description
Establishment cause	M		Enumerated (Originating Speech Call, Originating CS Data Call, Originating PS Data Call, Terminating Speech Call, Terminating CS Data Call, Terminating PS Data Call, Emergency Call, Inter-system cell re-selection, Location Update (LAU & RAU), IMSI Detach, SMS, Other)	

Note: These causes shall be aligned with causes received from higher layers.

10.2.3.9 Release cause

Cause for release of RRC connection.

10.2.3.10 Rejection cause

Cause for rejection of RRC connection establishment request.

10.2.3.11 Paging cause

Cause for a CN originated page.

Information Element/Group name	Presence	Range	IE type and reference	Semantics description
Paging cause	M		Enumerated(Terminating Speech Call, Terminating CS Data Call, Terminating PS Data Call, SMS, Other)	

Note: These causes shall be aligned with causes received from higher layers.

10.2.3.12 Initial UE capability

This is the UE capability information given in the RRC connection request message. The exact type of information is FFS.

Information Element/Group name	Presence	Range	IE type and reference	Semantics description
Support for Transport CH	O			Indicates which transport channels are supported

10.2.3.13 Power control capability

Information Element/Group name	Presence	Range	IE type and reference	Semantics description
Transmission power capability	M			

Note: The WG1 and WG4 discussion should be concluded before the contents of this IE can be finalized.

10.2.3.14 Code resource capability

Information Element/Group name	Presence	Range	IE type and reference	Semantics description
DL multi-code capability				
UL multi-code capability				
DL Spreading factor capability				
UL Spreading factor capability				

Note: The WG1 and WG4 discussion should be concluded before the contents of this IE can be finalized.

10.2.3.15 UE mode capability

Information Element/Group name	Presence	Range	IE type and reference	Semantics description
System capability		0 to <maxSystemCount>	Enumerated (UMTS, GSM, Others)	
UMTS capability		0 to <maxModeCount>	Enumerated (TDD, FDD)	
Chip rate capability				
Radio Frequency capability				
Variable duplex distance capability				

Range Bound	Explanation
<i>MaxSystemCount</i>	Maximum number of Systems supported by the UE
<i>MaxModeCount</i>	Maximum number of UMTS modes supported by the UE

Note: The WG1 and WG4 discussion should be concluded before the contents of this IE can be finalized.

10.2.3.16 Transport channel support capability

Information Element/Group name	Presence	Range	IE type and reference	Semantics description
Maximum number of DCHs			Integer	
Support for Transport CH				

Note: The WG1 and WG4 discussion should be concluded before the contents of this IE can be finalized.

10.2.3.17 Ciphering capability

Information Element/Group name	Presence	Range	IE type and reference	Semantics description
Ciphering Algorithm capability	M		Enumerated	

Note: The WG1 and WG4 discussion should be concluded before the contents of this IE can be finalized.

10.2.3.18 Macro diversity capability

Information Element/Group name	Presence	Range	IE type and reference	Semantics description
Maximum number of RLs	M		Integer	

Parameters	REFERENCE	TYPE	NOTE
Maximum number of RLs		M	

Note: The WG1 and WG4 discussion should be concluded before the contents of this IE can be finalized.

10.2.3.19 Cell update cause

Indicates the cause for s cell update. Examples of causes are cell reselection and periodic cell update.

10.2.3.20 URA update cause

Indicates the cause for s URA update. Examples of causes are change of URA and periodic URA update.

10.2.3.21 Number of RRC Message Transmissions

This IE indicates how many times the receiver of a message containing this IE shall transmit the RRC response message.

Information Element/Group name	Presence	Range	IE type and reference	Semantics description
Number of RRC Message Transmissions			Integer(1..8)	

10.2.3.22 Inter-system handover failure cause

The purpose of this IE is to provide a reason for the failure of the Inter-system handover.

10.2.3.23 Transmission probability

Indicates the probability for a mobile to be allowed to transmit on a DCH controlled by DRAC procedure.

10.2.3.24 Maximum bit rate

Indicates the maximum user bit rate allowed on a DCH controlled by DRAC procedure for the transmission period (Transmission time validity).

10.2.3.25 Capability Update Requirement

This IE indicates to the UE, which is capable of inter-system handover, whether it should send a complete update of its capabilities in the given system (e.g. GSM) immediately after having established an RRC connection.

Information Element/Group name	Presence	Range	IE type and reference	Semantics description
System	M		Enumerated (GSM,..)	
Early Capability Update	M		Boolean	

10.2.3.26 CPCH Parameters

These parameters are used by any UE using any CPCH set allocated to the Node B which is broadcasting this system information.

Information Element/Group name	Presence	Range	IE type and reference	Semantics description
NS_IP	M			Number of slots for initial delay for given priority level
Priority level	M			
Backoff control parameters				
N_ap_retrans_max	M			Max number of AP transmissions without AP-AICH response (access cycle), a PHY parameter.
N_access_fails	M			Max number of access cycles without AP-AICH response for link failure, a MAC parameter.
NS_bo_no_aich	M			Max number of slots for UE backoff after N_ap_retrans_max unsuccessful AP access attempts, a MAC parameter.
NF_bo_busy	M			Max number of frames for UE backoff after access attempt to busy CPCH, a MAC parameter.
NF_bo_all_busy	M			Max number of frames for UE backoff after access attempt to last busy CPCH, a MAC parameter.
NF_bo_collision	M			Max number of frames for UE backoff after collision on CPCH, a MAC parameter.
T_CPCH	M			CPCH channel timing -Number of slots used to determine Tau values for CPCH channel timing

Note: The WG1 and WG2 discussion should be concluded before the contents of these IEs can be finalized. All of the IEs may be considered optional (O) if the UE is programmed with default values for each IE.

10.2.3.27 UE Timers and Counters

This information element indicates timers and maximum values of each counter used in UE.

Information Element/Group name	Presence	Range	IE type and reference	Semantics description
T300	M			
N300	M			
T307	M			
T302	M			
T303	M			
N303	M			
N303	M			

10.2.3.28 AM_RLC error indication

Indicates AM_RLC unrecoverable error occurred on c-plane in the UE.

10.2.3.29 RLC re-configuration indicator

This IE is used to re-configure AM RLC on c-plane.

10.2.3.30 Failure cause

Cause for failure to perform the requested procedure.

Information Element/Group name	Presence	Range	IE type and reference	Semantics description
Failure cause			Enumerated (Configuration unacceptable, physical channel failure)	

10.2.3.31 UTRAN DRX cycle length

Indicates the time interval between monitoring paging occasions to be used by a specific UE in UTRAN Connected mode.

10.2.3.32 DRX Indicator

Indicates to a UE if DRX shall be used with Cell updating or URA updating or if no DRX at all shall be used.

10.2.4 Radio Bearer Information elements

10.2.4.1 RB identity

An identification number for the RB affected by a certain message.

10.2.4.2 RLC info

Information Element/Group name	Presence	Range	IE type and reference	Semantics description
Uplink RLC info				
RLC mode	M		enumerated (Acknowledged, Non Acknowledged, Transparent)	Note 1
PU size	O		Integer	
Transmission RLC discard	C- <i>NonTrOp</i>			
Transmission window size	C- <i>ACK</i>		Integer(1,8,16,32,128,256,512,768,1024,1536,2048,2560,3072,3584,4096)	Maximum number of RLC PUs sent without getting them acknowledged. This parameter is needed if acknowledged mode is used.
Polling info	C- <i>ACKOp</i>			
Downlink RLC info				
RLC mode	M		enumerated (Acknowledged, Non Acknowledged, Transparent)	Indicates if Acknowledged, Unacknowledged or Transparent mode RLC should be used. Note 1
In-sequence delivery	M		Boolean	Indication if RLC should preserve the order of higher layer PDUs when these are delivered.
PU Size)		Integer	Indicates the size of RLC Payload Units.
Reception RLC discard timer	C- <i>timer</i>			Elapsed time before a SDU is discarded. Only present if timer based discard mode without explicit signalling is chosen.
Receiving window size (FFS – Note 2)	C- <i>ACK</i>		Integer(1,8,16,32,128,256,512,768,1024,1536,2048,2560,3072,3584,4096)	Maximum number of RLC PUs allowed to be received. This parameter is needed if acknowledged mode is used.(Necessity is FFS.)
Downlink RLC status Info	C- <i>ACKOp</i>			

Condition	Explanation
<i>Timer</i>	This IE is only sent if timer based discard is used without explicit signalling
<i>NonTrOp</i>	This IE is optional for UTRAN to send if IE RLC mode is acknowledged or non-acknowledged
<i>AckOp</i>	This IE is optional for UTRAN to send if IE RLC mode is acknowledged
<i>Ack</i>	This IE is only present if IE RLC mode is acknowledged mode

Note 1: It is FFS if this IE always includes the same parameter values for both uplink and downlink RLC.

Note 2: It is FFS whether "Receiving window size" is necessary or not.

10.2.4.2.1 Transmission RLC Discard

Information Element/Group name	Presence	Range	IE type and reference	Semantics description
SDU Discard Mode	M		Enumerated(Timer based explicit, Timer based no explicit, Max_DAT retransmissions)	Different modes for discharge the RLC buffer on the transmitter side; Timer based with explicit signalling, Timer based without explicit signalling or Discard after Max_DAT retransmissions. For unacknowledged mode only Timer based without explicit signalling is applicable.
Timer_discard	C-timer			Elapsed time before a SDU is discarded.
Max_DAT	C-discard			Number of retransmissions of a PU before a SDU is discarded.

Condition	Explanation
<i>Timer</i>	This IE is only sent if timer based discard is used without explicit signalling
<i>Discard</i>	This IE is only sent when the SDU discard technique is to discard SDU's after a given number of PU re-transmissions

10.2.4.2.2 Polling info

Information Element/Group name	Presence	Range	IE type and reference	Semantics description
Timer_poll_prohibit	O			Minimum time between polls
Timer_poll	O			Started when poll is transmitted. New poll when timer expires and no STATUS received.
Poll_PU	O		Enumerated(1,2,4,8,16,32,64,128)	Poll at every Poll_PU PU
Poll_SDU	O		Enumerated(1,4,16,64)	Poll at every Poll_SDU SDU
Last transmission PU poll	M		Boolean	Indicates if poll at last PU in transmission buffer
Last retransmission PU poll	M		Boolean	Indicates if poll at last PU in retransmission buffer
Poll_Window	O		Enumerated(50,60,70,80,85,90,95,100)	Poll at Poll_Window % of transmission window
Timer_poll_periodic	O			Timer for periodic polling

Note: At least one or more parameters are necessary when polling info is sent.

10.2.4.2.3 Downlink RLC STATUS info

Information Element/Group name	Presence	Range	IE type and reference	Semantics description
Timer_Status_Prohibit	O			Minimum time between STATUS reports
Timer_EPC	O			Timer for EPC
Missing PU Indicator	M		Boolean	Indicates if UE should send a STATUS report for each missing PU that is detected
Timer_STAUS_periodic	O			Timer for periodic STATUS reports

10.2.4.3 Signalling link type

The purpose of the Signalling Link Type information element is to indicate the RLC parameters needed for the signalling link.

Each possible value of Signalling Link Type information element refers to a predefined set of parameters. Details FFS.

10.2.4.4 RB mapping info

A multiplexing option for each possible transport channel this RB can be multiplexed on.

Information Element/Group name	Presence	Range	IE type and reference	Semantics description
Information for each multiplexing option		1 to <maxMuxOptionsCount>		
Number of RLC logical channels		1 to 2		1 or 2 logical channels per RLC entity or radio bearer
Uplink transport channel type	M		Enumerated(DCH,RACH, CPCH,USCH)	CPCH is FDD only USCH is TDD only
Transport channel identity	M		Integer(0..maxTrChNum)	This is the ID of a transport channel that this RB could be mapped onto.
Logical channel identity	O		Integer(1..16)	This parameter is used to distinguish logical channels multiplexed by MAC on a transport channel.
MAC logical channel priority	O			This includes both priority between different users traffic when using a common or shared channel, and between different RBs (or logical channels) traffic for a certain user. Different priorities for one users RBs are mapped (through the MAC's T and C/T MUXes) to the TFC selection algorithm. [Note: Usage and precise meaning of this is FFS.]
Number of RLC logical channels		1 to 2		1 or 2 logical channels per RLC entity or radio bearer
Downlink transport channel type			Enumerated(DCH,FACH, DSCH)	
Transport channel identity	O		Integer(0..maxTrChNum)	
Logical channel identity	O		Integer(1..16)	

Range Bound	Explanation
<i>MaxMuxOptionsCount</i>	Maximum number of allowed multiplexing options that can be sent

Note: The necessity of dividing RB multiplexing into in uplink and downlink is FFS.

10.2.5 Transport CH Information elements

10.2.5.1 Transport Format Combination Set

Indicates the allowed combinations of already defined Transport formats.

Information Element/Group name	Presence	Range	IE type and reference	Semantics description
Transport format combination		1 to 1024		The first instance of the parameter <i>Transport format combination</i> correspond to Transport format combination 0, the second to transport format combination 1 and so on.
CTFC			Integer(0..MaxCTFC-1)	Integer number calculated according to clause 14.

Range Bound	Explanation
<i>MaxCTFC</i>	Maximum number of the CTFC value is calculated according to the following: $\sum_{i=1}^I (L_i - 1)P_i$ with the notation according to clause 14.

10.2.5.2 Transport Format Combination Subset

Indicates which Transport format combinations in the already defined Transport format combination set that are allowed.

Information Element/Group name	Presence	Range	IE type and reference	Semantics description
CHOICE Subset representation	M			
Minimum allowed Transport format combination number			Integer(0..MaxTFCValue-1)	The integer number is a reference to the <i>Transport format combination</i> , that arrived at that position in the <i>Transport Format Combination Set</i> .
Transport format combination		1 to <maxTFCcount>	Integer(0..MaxTFCValue-1)	The integer number(s) is a reference to the <i>Transport format combination</i> , that arrived at that position in the <i>Transport Format Combination Set</i> .

Range Bound	Explanation
<i>MaxTFCcount</i>	Maximum number of Transport Format Combinations that could be sent as the limited set that the UE is allowed to use.
<i>MaxTFCValue</i>	The max value of the Transport Format Combinations that currently is defined for this UE.

10.2.5.3 Transport channel identity

This information element is used to distinguish transport channels (both common and dedicated transport channels).

10.2.5.4 Transport Format Set (TFS)

Information Element/Group name	Presence	Range	IE type and reference	Semantics description
Dynamic Transport Format Information		1 to maxTFcount		The first instance of the parameter <i>Dynamic transport format information</i> correspond to Transport format 0 for this transport channel, the second to transport format 1 and so on.
Number of Transport blocks	M		Integer(0..4095)	
Transport Block Size			Integer(1..128), Integer(160..2040), Integer(2120..80..5000)	
Semi-static Transport Format Information				
Transmission time interval			Enumerated(10, 20, 40, 80)	
Type of channel coding			Enumerated(No coding, Convolutional, Turbo)	
Coding Rate	C-Coding		Enumerated(1/2, 1/3)	
Rate matching attribute			Integer(1..maxRM)	
CRC size	M		Enumerated(0, 8, 16, 24)	

Condition	Explanation
<i>Blocks</i>	This IE is only present if IE Number of Transport Blocks' is greater than 0.
<i>Coding</i>	This IE is only present if IE Type of channel coding' is Convolutional' or Turbo'

Range Bound	Explanation
<i>MaxTFcount</i>	Maximum number of different transport formats that can be included in the Transport format set for one transport channel is 32.
<i>MaxRM</i>	Maximum number that could be set as rate matching attribute for a transport channel.

<Note: The parameter 'rate matching attribute' is in line with the RAN WG1 specifications. However, it is not currently in line with the description in 25.302.>

10.2.5.5 Dynamic Control

Indicates if this transport channel is controlled by DRAC procedure or not.

10.2.5.6 Transmission time validity

Indicates the duration for which permission is granted on a DCH controlled by DRAC procedure.

10.2.5.7 Time duration before retry

Indicates the time duration before retrying to get the transmission permission on a DCH controlled by DRAC procedure, in case permission has not been granted.

10.2.5.8 Silent period duration before release

Indicates the maximum silent period duration before releasing the resource. This parameter may be merged with the Fkp-b parameter defined in the 'Transmission stop and resumption control' procedure defined in [1].

(Note: [1] RAN/WG1 S1.14 document)

10.2.5.9 Transport Format Combination Set Identity

Indicates the identity of every TFCS within a UE (TDD only)

10.5.2.10 Transparent mode signalling info

This information element points out a transport channel that is used for transparent mode signalling, and which type of message that is sent on the DCCH mapped on that channel.

Information Element	Presence	Range	IE type and reference	Semantics description
Transport channel identity				Transport channel used for transparent mode signalling DCCH
Message type			Enumerated (TRANSPORT FORMAT COMBINATION CONTROL)	Indicates which type of message sent on the transparent mode signalling DCCH

10.2.6 Physical CH Information elements

10.2.6.1 Frequency info

Information Element/Group name	Presence	Range	IE type and reference	Semantics description
UTRA RF Channel Number	M			A unique identifier for the channel raster and its associated parameters (as described by the other parameters within this info element)
Raster Position	O			Provided to enable the definition of permitted carrier frequency associated to the specific UTRA RF Channel Number parameter
CHOICE <i>mode</i>				
FDD				
Duplex distance	O			
Chip rate	O			
RF Channel Type	O	enumerated (TDD, FDD)		Identifies whether the UTRA RF Channel Number corresponds to FDD/ TDD/ uplink/ downlink only

10.2.6.2 Primary CPICH info (FDD only)

Information Element/Group name	Presence	Range	IE type and reference	Semantics description
Primary scrambling code	M		Integer(0..511)	

10.2.6.3 Secondary CPICH info (FDD only)

Information Element/Group name	Presence	Range	IE type and reference	Semantics description
DL scrambling code	C- <i>PrimCPICH</i>			
Channelization code	M			

Condition	Explanation
<i>PrimCPICH</i>	This IE is only included if the DL scrambling code is different to that of the primary CPICH

10.2.6.4 Primary CCPCH info

Information Element/Group name	Presence	Range	IE type and reference	Semantics description
CHOICE <i>mode</i>				
FDD				
STTD indicator	O			
TDD				
Timeslot	M			The PSCH timeslot (the value k)
Midamble type	O			Long or short midamble
Cell parameters ID	M			For the cell parameter table
Sync case	M			Case 1,2, or 3

10.2.6.5 Secondary CCPCH info

Information Element/Group name	Presence	Range	IE type and reference	Semantics description
CHOICE <i>mode</i>				
FDD				
Secondary scrambling code	O		Integer (0..14)	
STTD indicator	O			
Spreading factor	M		Enumerated(4, 16, 32, 64, 128, 256)	
Code number	M		Integer(0..maxCodeNum)	
Pilot symbol existence	M		Boolean	
TFCI existence	M		Boolean	
Fixed or Flexible Position	M		Enumerated (Fixed, Flexible)	
Timing Offset	O			Time difference between PCCPCH
TDD				
Channelization code	M			
Time slot	M			Timeslot of the Secondary CCPCH
Midamble type	O			Long or short midamble for each time slot
Midamble shift	M			Midamble shift of Secondary CCPCH for each timeslot
Superframe offset	M			Offset of the first CCPCH transmission in a 72 superframe
Repetition period	M			Repetition period of the CCPCH in the 72 superframe
Repetition length	M			Length of the allocation for each repetition

Condition	Explanation

Range Bound	Explanation
<i>MaxCodeNum</i>	Maximum number of codes for one spreading factor (SF) is equal to SF-1.

10.2.6.6 PRACH info (for RACH)

Information Element/Group name	Presence	Range	IE type and reference	Semantics description
CHOICE <i>mode</i>				
FDD				
Available Signature		1 to <maxSigNum>		
Signature	M		Enumerated (0,1,2.....15)	
Available SF		1 to <maxSf>		
SF	M		Enumerated (32,64,128,256 chip/sym)	
Scrambling code word number	M		Enumerated (0,1,2.....255)	
Puncturing Limit	M			
Available Sub Channel number		1 to <maxSubChNum >		
Sub Channel number	M		Enumerated (0,1,2.....11)	
Persistence factor N	M		ffs	0-1 step ffs
TDD				
Spreading factor	M			Spreading factor 8 or 16 are possible
Timeslot	M			
Channelisation code	M			1:1 mapping between spreading code and midamble shift
Midamble	O			Basic midamble code for PRACH (two different codes possible)

Range Bound	Explanation
<i>MaxSubChNum</i>	Maximum number of available sub channels
<i>MaxSigNum</i>	Maximum number of available signatures
<i>MaxSf</i>	Maximum number of available SF

10.2.6.7 PRACH power control info

Information Element/Group name	Presence	Range	IE type and reference	Semantics description
CHOICE <i>mode</i>				
FDD				
Primary CPICH DL TX power	M			
UL interference	M			
Constant value	M			
Power offset P_0	M			Power step when no acquisition indicator is received
Power offset P_1	M			Power step when negative acquisition is received
Power offset P_{p-m}	M			Power offset between preamble and the message part
TDD				

NOTE: The usage of these parameters needs clarification and are also dependent on the WG1 RACH discussions.

10.2.6.8 Uplink DPCH info

Information Element/Group name	Presence	Range	IE type and reference	Semantics description
CHOICE <i>mode</i>				
FDD				
UL scrambling code				What short or long uplink scrambling code a certain UE should use
Scrambling code type	M		Enumerated(short, long)	
Scrambling code number	M		Integer(0..16 777215)	(24 bits)
Number of DPDCH	M		Integer(1.. maxDPDCH count)	
DPDCH channelization code	<i>C-Single</i>		Enumerated(4, 8, 16, 32, 64, 128, 256)	SF of the channelization code for data part
TFCI existence	M	Boolean		
Number of FBI bits	O		Enumerated(1, 2 bits)	If neither SSST nor FB Mode Transmit Diversity Signalling is supported, this parameter is not needed and the number of FBI bits is set to "0".
Puncturing Limit	M			
TDD				
Scrambling code type	M		Enumerated(short, long)	
Scrambling code number	M		Integer(0..16 777215)	(24 bits)
DPCH Activation Time	O			Frame number start of allocation period (the Superframe offset can be derived)
Duration	O			Total number of frames
Repetition period	O			Repetition period of the DPCH in the 72 Superframe
Repetition length	O			Length of the allocation for each repetition
TFCI presence	O			Coding for a TFCI field in a DPCH
DPCH channelisation code	M			SF of the channelisation code of the data part for each DPCH
Timeslot	M			Timeslot of DPCH for each DPCH
Midamble type	O			Short or long, for each time slot, for each DPCH
Midamble shift	M			Midamble shift for each timeslot for each DPCH
DPCH activation time	O			Frame number start of allocation (the Superframe OFFset can be derived) for each timeslot for each DPCH

Condition	Explanation
<i>Single</i>	This IE is included if IE Number of DPDCH is '1'

Range Bound	Explanation
<i>MaxDPDCHcount</i>	Maximum number of DPDCH's

10.2.6.9 Uplink DPCH power control info

Parameters used by UE to set DPCH initial output power and to use for closed-loop power control.

Information Element/Group name	Presence	Range	IE type and reference	Semantics description
CHOICE <i>mode</i>				
FDD				
Constant value				Necessity is ffs
UL interference				Necessity is ffs
TPC step size	M		Enumerated (1dB, 2dB)	
TDD				
UL target SIR	M			

10.2.6.10 Downlink DPCH info

Information Element/Group name	Presence	Range	IE type and reference	Semantics description
CHOICE <i>mode</i>				
FDD				
Secondary scrambling code	O		Integer (0..14)	
DL channelization code		1 to <maxChan count>		Channelization codes to be used in the downlink for DPCH
Spreading factor	M		Enumerated(4, 16, 32, 64, 128, 256, 512)	
Code number	M		Integer(0..maxCodeNum)	
Fixed or Flexible Position	M		Enumerated (Fixed, Flexible)	
TFCI existence	M		Boolean	
Number of bits for Pilot bits	C-SF		Enumerated (2,4,8 bits)	
STTD Indicator	C-STTD			
TDD				
DPCH Activation Time	O			Frame number start of allocation period (the Superframe offset can be derived)
Duration	O			Total number of frames
Repetition period	O			Repetition period of the DPCH in the 72 Superframe
Repetition length	O			Length of the allocation for each repetition
TFCI presence	O			Coding for a TFCI field in a DPCH
DPCH channelisation code	M			SF of the channelisation code of the data part for each DPCH
Timeslot	M			Timeslot of DPCH for each DPCH
Midamble type	O			Short or long, for each time slot, for each DPCH
Midamble shift	M			Midamble shift for each timeslot for each DPCH
DPCH activation time	O			Frame number start of allocation (the Superframe OFFset can be derived) for each timeslot for each DPCH

Condition	Explanation
<i>STTD</i>	This IE is only sent if STTD is applied
<i>SF</i>	This IE is only sent if SF=128 or 256 is applied. If SF=256, value is 2,4 or 8 If SF=128, value is 4 or 8

Range Bound	Explanation
<i>MaxChanCount</i>	Maximum number of channelization codes used for DL DPCH
<i>MaxCodeNum</i>	Maximum number of codes for one spreading factor

	(SF) is equal to SF-1.
--	------------------------

10.2.6.11 FB Mode Transmit Diversity signalling indicator

Information Element/Group name	Presence	Range	IE type and reference	Semantics description
Mode	M		Enumerated (mode1, mode2)	Associated with DL DPCH info (but not for each RL)

Note: These parameters shall be set optionally associated with DL DPCH info but not for each RL.

10.2.6.12 SSdT indicator (FDD only)

This information element indicates the status (e.g. initiated/terminated) of the Site Selection

Diversity Transmit power control (SSdT). In the direction UTRAN to UE it is used to change the SSdT status. In the direction UE to UTRAN it is used to confirm the SSdT status by the UE. The parameter 'code word set' indicates how cell identities are coded (using many bits or few, values are long, medium, or short).

Information Element/Group name	Presence	Range	IE type and reference	Semantics description
D field	M		Enumerated (1, 2 bits)	
Code Word Set	M		Enumerated (long, medium, short, SSdT off)	

Note: These parameters shall be set optionally associated with DL DPCH info but not for each RL.

10.2.6.13 SSdT cell identity (FDD only)

This IE is used to associate a cell identity with a given radio link

Information Element/Group name	Presence	Range	IE type and reference	Semantics description
Temporary id	M			

10.2.6.14 Gated Transmission Control info (FFS) (FDD only)

Information Element/Group name	Presence	Range	IE type and reference	Semantics description
Gating pattern	M		Enumerated (periodic, random-(FFS))	
Gating rate	M		Enumerated (Full rate, 1/3, 1/5 or 0)	Indicates gated transmission rate

10.2.6.15 Default DPCH Offset Value (FDD only)

Indicates the default offset value within interleaving size at a resolution of 512chip (1/5 slot) to offset CFN in the UE. This is used to distribute discontinuous transmission periods in time and also to distribute NodeB-RNC transmission traffics in time. Even though the CFN is offset by DOFF, the start timing of the interleaving will be the timing that $CFN \bmod (\text{interleaving size}) \neq 0$ (e.g. interleaving size: 2,4,8) in both UE and SRNC.

10.2.6.16 RF channel number priority

Information Element/Group name	Presence	Range	IE type and reference	Semantics description
RF channel number priority	M			Enable the setting of priority of the UTRA RF Channel Number parameter, to facilitate efficient system/ cell/ channel identification and selection processes

[Editor's note: a Liaison has been sent to determine whether this IE is necessary]

10.2.6.17 AICH Info (FDD only)

Information Element/Group name	Presence	Range	IE type and reference	Semantics description
Secondary scrambling code	O		Integer(0..14)	
Channelization code	M		Integer(0..255)	SF is fixed and equal to 256
STTD indicator	O			
AICH transmission timing	M		Enumerated (0, 1)	

<i>primCPICH</i>	
------------------	--

10.2.6.18 PICH Info

Information Element/Group name	Presence	Range	IE type and reference	Semantics description
CHOICE <i>mode</i>				
FDD				
Secondary scrambling code	O		Integer(0..14)	
Channelisation code	M		Integer(0..255)	SF is fixed and equal to 256
Number of PI per frame	M		Enumerated (18, 36 72 144)	
STTD indicator	O			
TDD				
Channelisation code	M			
Timeslot	M			
Midamble type	O			
Midamble shift	M			
Superframe offset	M			
Repetition period	M			
PICH repetition cycle	M			
M	FFS			

10.2.6.19 PRACH info (for FAUSCH) (FDD only)

Information Element/Group name	Presence	Range	IE type and reference	Semantics description
Fast access slot		1 to <maxAS>		
Preamble spreading code		1 to <maxPreambleSC>		
Preamble signature		1 to <maxPreambleSigs>		
FAUSCH usage				Indicates true/false for "use for DCH allocation", "use for USCH capability request".

Range Bound	Explanation
<i>MaxAS</i>	Number of access slots for the preambles (Every 16 chips)
<i>MaxPreambleSC</i>	Number of preamble spreading codes
<i>MaxPreambleSigs</i>	Number of allowed preamble signatures

10.2.6.20 CPCH set info (FDD only)

This IE may be broadcast in the System Information message or assigned by SRNC. It is pseudo-static in a cell.

Information Element/Group name	Presence	Range	IE type and reference	Semantics description
CPCH set ID	C			Indicates the ID number for a particular CPCH set allocated to a cell. Necessity is FFS.
AP preamble code	O			256 chip preamble code for AP in UL
AP-AICH channelisation code	O			256 chip channelisation code for AP-AICH in DL
CD preamble code	O			256 chip preamble code for CD in UL
CD-AICH channelisation code	O			256 chip channelisation code for CD-AICH in DL
Signature code N	O			Signature code for CPCH channel selection in UL. 16 signatures, 16 bits each, N from 1-16.
CPCH channel info		0 to <maxCPC Hs>		
UL scrambling code	O			
UL channelisation code	O			
DL channelisation code	O			
NF_max (Max packet length in frames)	O			
Signature pointer (maps to set of signatures for this channel)	O			

Range Bound	Explanation
<i>MaxCPC Hs</i>	Maximum number of CPCH channels in a CPCH set (max=16 with 1 signature per channel)

Note: Whether several CPCH Set Info with different QoS can be set in a cell is FFS.

10.2.6.21 CPCH persistency values (FDD only)

This IE is dynamic and is used by RNC for load balancing and congestion control. This is broadcast often in the system information message.

Information Element/Group name	Presence	Range	IE type and reference	Semantics description
CPCH set ID	M			Identifier for CPCH set info.
PV_CPCHn	M			Persistency value for CPCHn. One PV for each CPCH channel in this CPCH set.

10.2.6.22 Downlink DPCH compressed mode info (FDD only)

This information element indicates the parameters of the downlink compressed mode to be used by the UE in order to perform inter-frequency measurements.

Information Element/Group name	Presence	Range	IE type and reference	Semantics description
TGL	M			Transmission Gap length expressed in number of slots
CFN	M			Connection Frame Number when the first compressed frame starts
SN	M			Slot number when the transmission gap starts (within the CFN)
TGP	M			Transmission Gap Period indicates the number of frames between two sets of consecutive compressed frames containing up to 2 transmission gaps
TGD	M			Transmission Gap distance indicates the number of frames between two consecutive transmission gaps within a transmission gap period.
PD	M			Total number of TGPs
PCM	M			Power control mode during the frame after the compressed frame. Indicates whether normal PC mode or compressed PC mode is applied
DeltaEb/No	M			Delta in DL Eb/No target value to be set in the UE during the compressed frames (Note 1)
DeltaEb/Noafter	M			Delta in DL Eb/No target value to be set in the UE one frame after the compressed frames (Note 1)

[Editors Note 1: The current assumptions is that the delta will be zero or positive]

10.2.6.23 Downlink DPCH power control information

This information element indicates the range of Eb/No target values and the initial Eb/No target value to be set in the UE on this physical, channel for the downlink closed loop power control.

Information Element/Group name	Presence	Range	IE type and reference	Semantics description
DPC Mode	M		Enumerated (mode0, mode1)	
Initial Eb/No target value	M			Initial Eb/No value to be used for the DL closed loop power control.
Min Eb/No target value	M			Minimum Eb/No value that can be set by the DL closed loop power control.
Max Eb/No target value	M			Maximum Eb/No value that can be set by the DL closed loop power control.

10.2.6.24 Downlink Outer Loop Control

This information element indicates whether the UE is allowed or not to increase its downlink Eb/No target value above the current value.

10.2.6.25 Timing Advance (TDD only)

Information Element/Group name	Presence	Range	IE type and reference	Semantics description
UL Timing Advance	M			

10.2.6.26 PSCH Timeslot (TDD only)

Information Element/Group name	Presence	Range	IE type and reference	Semantics description
PSCH information	M			

10.2.6.27 ASC Info (TDD only)

Information Element/Group name	Presence	Range	IE type and reference	Semantics description
Access Service Class 1 Support	O			Each PRACH info IE in System Information is associated with an ASC info IE. Any one RACH can support multiple ASCs.
Access Service Class 2 Support	O			
Access Service Class 3 Support	O			

10.2.6.28 PUSCH info (TDD only)

Information Element/Group name	Presence	Range	IE type and reference	Semantics description
UL scrambling code	M			What short or long uplink scrambling code a certain UE should use
PUSCH activation time	M			Frame number start of allocation period (the Superframe Offset can be derived)
Duration	M			Total number of frames
Repetition Period	O			Repetition period of the PUSCH in the 72 Superframe
Repetition length	O			Length of the allocation for each repetition
TFCI presence	O			List of timeslots in which a TFCI field is coded
Individual PUSCH info		1 to <maxPUSCHcount>		Different for each PUSCH
PDCH channelization code	M			SF of the channelization code
Timeslot	M			Timeslot number
Midamble Type	O			Short or long midamble
Midamble Shift	M			Midamble shift of the PUSCH

Range Bound	Explanation
<i>MaxPUSCHcount</i>	Maximum number of PUSCHs

10.2.6.29 PDSCH info (TDD only)

Information Element/Group name	Presence	Range	IE type and reference	Semantics description
PDSCH activation time	M			Frame number start of allocation period (the Superframe Offset can be derived)
Duration	M			Total number of frames
Repetition Period	O			Repetition period of the DDSCH in the 72 Superframe
Repetition length	O			Length of the allocation for each repetition
TFCI presence	O			List of timeslots in which a TFCI field is coded
Individual PDSCH info		1 to <maxPDSCHcount>		Different for each PDSCH
PDCH channelization codes	M			List of channelization codes used in the downlink for PUSCH
Timeslot	M			Timeslot number
Midamble Type	O			Short or long midamble
Midamble Shift	M			Midamble shift of the PUSCH

Range Bound	Explanation
<i>MaxPDSCHcount</i>	Maximum number of PDSCHs

10.2.6.30 PUSCH power control info (TDD only)

Interference level measured for a frequency at the UTRAN access point used by UE to set PUSCH output power.

Information Element/Group name	Presence	Range	IE type and reference	Semantics description
UL target SIR	M			

10.2.6.31 Maximum allowed UL TX power

This information element indicates the maximum allowed uplink transmit power.

Information Element	Presence	Range	IE type and reference	Semantics description
Maximum allowed UL TX power				

10.2.7 Measurement Information elements

10.2.7.1 Measurement Identity Number

A reference number that is used by the UTRAN at modification and release of the measurement, and by the UE in the measurement report.

10.2.7.2 Measurement Command

One out of three different measurement commands

- Setup: Setup a new measurement.
- Modify: Modify a previously specified measurement, e.g. change the reporting criteria.

- Release: Stop a measurement and clear all information in the UE that are related to that measurement.

10.2.7.3 Measurement Type

One of the types from a predefined list where each type describes what the UE shall measure. The types are:

- Intra-frequency measurements
- Inter-frequency measurements
- Inter-system measurements
- Traffic volume measurements
- Quality measurements
- UE internal measurement

10.2.7.4 Reference time difference to cell

The reference time difference to cell indicates the time difference between the primary CCPCH of the current cell and the primary CCPCH of a neighbouring cell. It is notified to UE by System Information or Measurement Control message.

In case of macro-diversity the reference is the primary CCPCH of one the cells used in the active set.

Editors note: Exactly how the reference cell is pointed out in this case in the messages is FFS.

10.2.7.5 Measured time difference to UTRA cell

For FDD: The measured time difference to cell indicates the time difference which is measured by UE between CFN in the UE and the SFN of the target neighbouring cell. It is notified to SRNC by Measurement Report message or Measurement Information Element in other RRC messages.

For TDD: This is the relative time difference in the frame timing between the serving and the target cell measured at the UE.

10.2.7.6 Measured time difference to GSM cell

(Note: Only the section is made.)

10.2.7.7 Measurement reporting mode

Contains the type of Measurement Report transfer mode and the indication of periodical/event trigger.

Information Element/Group name	Presence	Range	IE type and reference	Semantics description
Measurement Report Transfer Mode	M		enumerated (Acknowledged / Unacknowledged)	
Periodical Reporting / Event Trigger Reporting Mode	M		enumerated (Periodical reporting / Event trigger)	

10.2.7.8 Intra-frequency cell info

Contains the measurement object information for an intra-frequency measurement.

Information Element/Group name	Presence	Range	IE type and reference	Semantics description
Primary CCPCH info	M			
Primary CCPCH DL TX power	O			
UL load	O			FFS
SFN Measurement Indicator	M			
DL CCTrCH info	O			List of TFCS ID's to measure
DL Timeslot info	O			List of timeslots to measure

10.2.7.9 Inter-frequency cell info

Contains the measurement object information for an inter-frequency measurement.

Information Element/Group name	Presence	Range	IE type and reference	Semantics description
Frequency info	M			
Primary CCPCH info	M			
Primary CCPCH DL TX power	O			FFS
UL load	O			FFS
Reference time difference to cell	O			FFS

10.2.7.10 Inter-system cell info

Contains the measurement object information for an inter-system measurement.

Information Element/Group name	Presence	Range	IE type and reference	Semantics description
System type	M		enumerated (GSM,..)	
System specific measurement info			enumerated (frequency, timeslot, colour code, output power.)	

10.2.7.11 Traffic volume measurement object

Contains the measurement object information for a traffic volume measurement.

Information Element/Group name	Presence	Range	IE type and reference	Semantics description
Target Transport CH ID	M			

10.2.7.12 Quality measurement object (FFS)

(Note: Only the section is made.)

10.2.7.13 Intra-frequency measurement quantity

The quantity the UE shall measure in case of intra-frequency measurement. It also includes the filtering of the measurements.

Information Element/Group name	Presence	Range	IE type and reference	Semantics description
Primary CCPCH RX E_c/I_0	O			One of these is mandatory
Primary CCPCH RX SIR (RSCP/ISCP)	O FFS			
Primary CCPCH RX power (RSCP)	O FFS			
Path loss	O FFS			
Path loss plus UL load	O FFS			
CHOICE mode				
TDD				
DL CCTrCH SIR	O			
DL Timeslot ISCP	O			

(Note: Above measurements except for E_c/I_0 are not concluded in WG1)

10.2.7.14 Inter-frequency measurement quantity (FFS)

The quantity the UE shall measure in case of inter-frequency measurement. It also includes the filtering of the measurements.

Information Element/Group name	Presence	Range	IE type and reference	Semantics description
E_c/I_0	O FFS			One of these is mandatory
DL Path loss	O FFS			
SIR	O FFS			
DL path loss plus UL interference	O FFS			
Received signal code power (RSCP)	O FFS			

10.2.7.15 Inter-system measurement quantity (FFS)

The quantity the UE shall measure in case of inter-system measurement. It also includes the filtering of the measurements.

Information Element/Group name	Presence	Range	IE type and reference	Semantics description
E_c/I_0	O FFS			One of these is mandatory
Signal strength	O			
Path loss	O FFS			
Colour code	C - GSM			

Condition	Explanation
GSM	This information element is only sent when the system being measured is a GSM system

10.2.7.16 Traffic volume measurement quantity

Contains the measurement quantity information for a traffic volume measurement.

Information Element/Group name	Presence	Range	IE type and reference	Semantics description
RLC buffer payload	M			
Average RLC buffer payload	O			
Variance of RLC buffer payload	O			

(Note: If there is no other measurement quantity, this parameter can be removed since it can be implicitly known by UE.)

10.2.7.17 UE internal measurement quantity

The quantity the UE shall measure in case of UE internal measurement.

Information Element/Group name	Presence	Range	IE type and reference	Semantics description
UE Tx power	O			One of these is mandatory
UE RSSI	O			

10.2.7.18 Quality measurement quantity (FFS)

(Note: Only the section is made.)

10.2.7.19 Intra-frequency reporting quantity

Contains the reporting quantity information for an intra-frequency measurement.

Information Element/Group name	Presence	Range	IE type and reference	Semantics description
Primary CCPCH RX E_c/I_0	O			
Primary CCPCH RX SIR (RSCP/ISCP)	O			FFS
Primary CCPCH RX power (RSCP)	O			FFS
Path loss plus UL load	O			FFS
Measured time difference to cell	O			
DL Transport CH BLER	O			
DL Transport CH BER	O			FFS
UE Transmission Power	O			
UE Position	O			
Cell ID	O			FFS
CHOICE mode				
TDD				
DL CCTrCH SIR				
DL Timeslot ISCP				

(Note: It is FFS whether the reporting quantity parameters used in different measurement types can be used commonly for all types of reporting quantity. If they can, only "Reporting Quantity" is enough instead of specifying 5 types of reporting quantity.)

10.2.7.20 Intra-frequency reporting quantity for RACH reporting

Contains the reporting quantity information for an intra-frequency measurement report, which is sent on the RACH.

Information Element/Group name	Presence	Range	IE type and reference	Semantics description
Primary CCPCH RX E_c/I_0	O			
Primary CCPCH RX SIR (RSCP/ISCP)	O			FFS
Primary CCPCH RX power (RSCP)	O			FFS
Path loss plus UL load	O			FFS
Measured time difference to cell	O			
DL Transport CH BLER	O			FFS
DL Transport CH BER	O			FFS
UE Transmission Power	O			FFS
UE Position	O			FFS
Cell ID	O			FFS
CHOICE mode				
TDD				
DL Timeslot ISCP				

10.2.7.21 Inter-frequency reporting quantity (FFS)

Information Element/Group name	Presence	Range	IE type and reference	Semantics description
Measured time difference to cell	O			
Primary CCPCH R_x RSCP	O			
E_c/N_0 of Primary CCPCH	O			

10.2.7.22 Inter-system reporting quantity (FFS)

Information Element/Group name	Presence	Range	IE type and reference	Semantics description
Observed time difference to GSM cell				
RSS I on BCCH carrier				

10.2.7.23 Traffic volume reporting quantity

Contains the reporting quantity information for a traffic volume measurement.

Information Element/Group name	Presence	Range	IE type and reference	Semantics description
RLC buffer payload for each RB	O			
Average RLC buffer payload for each RAB	O			
Variance of RLC buffer payload for each RAB	O			
Event type on each Transport channel	O			Indicates overflow or underflow
DL Transport CH BLER	O			
DL Transport CH BER	O			FFS
UE Transmission Power	O			
UE Position	O			
Cell ID	O			FFS

(Note: It is FFS whether the reporting quantity parameters used in different measurement types can be used commonly for all types of reporting quantity. If they can, only "Reporting Quantity" is enough instead of specifying 5 types of reporting quantity.

10.2.7.24 Quality reporting quantity (FFS)

(Note: Only the section is made.)

10.2.7.25 Intra-frequency measurement reporting criteria

The triggering of the event-triggered reporting for an intra-frequency measurement. All events concerning intra-frequency measurements are labeled 1x where x is a, b, c...

Event 1a: A Primary CPICH enters the Reporting Range [Note1](FDD only)

Event 1b: A Primary CPICH leaves the Reporting Range [Note2] (FDD only)

Event 1c: A Non-active Primary CPICH becomes better than an active Primary CPICH [Note3](FDD only)

Event 1d: Change of best cell [Note4, 5] (FDD only)

Event 1e: Other types of ranking of Primary CPICHs (FFS) (FDD only)

Event 1f: A Primary CCPCH becomes worse than an absolute threshold (FDD only)

Event 1g: Change of best cell in TDD

Event 1h: DL CCTrCH below a certain threshold (TDD only)

Event 1i: DL Timeslot ISCP below a certain threshold (TDD only)

Event 1j: DL Timeslot ISCP above a certain threshold (TDD only)

Information Element/Group name	Presence	Range	IE type and reference	Semantics description
Max number of reporting cells	O			Common parameter for all events
RACH measurement reporting parameters				Group name
Maximum number of reported cells on RACH	O			
Parameters required for each event		0 to <maxEvent count>		
Event ID	M			1a, 1b, 1c, 1d, 1e, 1f, 1g, 1h, 1i, 1j
Triggering condition	C - clause 0		enumerated	Indicates whether event shall be triggered by: -Active set cells only -Monitored set cells only -Both active set cells and monitored set cells
Reporting Range	C - clause 1			In event 1a,1b
S	C - clause 1			In event 1a,1b
Hysteresis	C & O - clause 2			In event 1a, 1b, 1c,1d, 1g, 1h, 1i or 1j
Reporting deactivation threshold	C - clause 3			In event 1a Indicates the maximum number of cells allowed in the active set in order for event 1a to occur. Value 0 indicates "not applicable".
Replacement activation threshold	C - clause 4			In event 1c Indicates the minimum number of cells allowed in the active set in order for event 1c to occur. Value 0 indicates "not applicable".
Time to trigger	M			Indicates the period of time between the timing of event detection and the timing of sending Measurement Report.
Amount of reporting	M			Measurement for the indicated Transport CH ID is "released" after the indicated amount of reporting from the UE itself. FFS
Reporting interval	M			Indicates the interval of periodical reporting when such reporting is triggered by an event. A zero value indicates that event triggered periodical reporting shall not be applied.

Condition	Explanation
Clause 0	This parameter is only sent in event 1a,1b, 1e, 1f
Clause 1	This parameter is only sent in event 1a,1b
Clause 2	This parameter is only sent in event 1a,1b, 1c,1d, 1g, 1h, 1i, 1j
Clause 3	This parameter is only sent in event 1a
Clause 4	This parameter is only sent in event 1c

[Note1: whether or not PCCPCH can be active is FFS]

[Note2: whether or not PCCPCH can be non-active is FFS]

[Note3: Details are FFS: It has been suggested to divide this event into two cases; I) a non-active PCCPCH exceeds the weakest active PCCPCH, II) a non-active PCCPCH exceeds the strongest active PCCPCH]

[Note4: When best PCCPCH in active set changes, all active cells are reported.]

[Note5: Whether this event can result in the reporting of non-active cells in addition to active cells is FFS.]

10.2.7.26 Inter-frequency measurement reporting criteria (FFS)

The triggering of the measurement report, e.g. periodical, event-triggered or immediate reporting for an inter-frequency measurement. Here is also specified if the measurement report should be transmitted using either acknowledged or unacknowledged data transfer on the DCCH.

Information Element/Group name	Presence	Range	IE type and reference	Semantics description

10.2.7.27 Inter-system measurement reporting criteria (FFS)

The triggering of the measurement report, e.g. periodical, event-triggered or immediate reporting for an inter-system measurement. Here is also specified if the measurement report should be transmitted using either acknowledged or unacknowledged data transfer on the DCCH.

10.2.7.28 Traffic volume measurement reporting criteria

Contains the measurement reporting criteria information for a traffic volume measurement.

Information Element/Group name	Presence	Range	IE type and reference	Semantics description
Parameters sent for each transport channel		1 to <maxTrCH count>		
Transport CH ID	M			
Upper Threshold	M			
Lower Threshold	O			
Time to trigger	M			Indicates the period of time between the timing of event detection and the timing of sending Measurement Report.
Pending time after trigger	M			Indicates the period of time during which it is forbidden to send any new measurement reports with the same measurement ID even if the triggering condition is fulfilled again.
Tx interruption after trigger	M			Indicates whether or not the UE shall block DTCH transmissions on the RACH after a measurement report is triggered.
Amount of reporting	M			Measurement for the indicated Transport CH ID is 'released' after the indicated amount of reporting from the UE itself. FFS
Reporting interval	M			Indicates the interval of periodical report during the event is in the detected state FFS

Range Bound	Explanation
<i>MaxTrCHcount</i>	Maximum number of transport channels

10.2.7.29 Quality measurement reporting criteria (FFS)

(Note: Only the section is made.)

10.2.7.30 UE internal measurement reporting criteria

The triggering of the event-triggered reporting for a UE internal measurement. All events concerning UE internal measurements are labelled 6x where x is a, b, c.... In TDD, the events 6a - 6d are measured and reported on timeslot basis.

Event 6a: The UE Tx power becomes larger than an absolute threshold

Event 6b: The UE Tx power becomes less than an absolute threshold

Event 6c: The UE Tx power reaches its minimum value

Event 6d: The UE Tx power reaches its maximum value

Event 6e: The UE RSSI reaches the UE's dynamic receiver range

Information Element/Group name	Presence	Range	IE type and reference	Semantics description
Parameters sent for each UE internal measurement event		1 to <maxEvent count>		
Event ID	M			6a, 6b, 6c, 6d or 6e
Time-to-trigger	M			Indicates the period of time between the timing of event detection and the timing of sending Measurement Report.
Tx power threshold	C - clause 1			In event 6a, 6b

Parameters		REFERENCE	TYPE	NOTE
For each event	Event ID		M	6a, 6b, 6c, 6d or 6e
	Time-to-trigger		M	Indicates the period of time between the timing of event detection and the timing of sending Measurement Report.
	Tx power threshold		C	In event 6a, 6b

Condition	Explanation
<i>Clause 1</i>	This parameter is only sent in event 6a,6b

10.2.7.31 Periodical reporting criteria

Contains the periodical reporting criteria information. It is necessary only in the periodical reporting mode.

Information Element/Group name	Presence	Range	IE type and reference	Semantics description
Max number of reporting cells	O			Indicates the maximum number of cells to report.
Amount of reporting	O			Measurement is "released" after the indicated amount of reporting from the UE itself
Reporting interval	O			Indicates the interval of periodical report.

10.2.7.32 Intra-frequency measurement event results

This IE contains the measurement event results that are reported to UTRAN for intra-frequency measurements.

Information Element/Group name	Presence	Range	IE type and reference	Semantics description
Event ID	M			
Primary CCPCH info	O			
CHOICE <i>mode</i>				
TDD				
DL CCTrCH SIR	O			
DL Timeslot ISCP	O			

10.2.7.33 Inter-frequency measurement event results (FFS)

This IE contains the measurement event results that are reported to UTRAN for inter-frequency measurements. The further division of this IE into parameters is FFS.

10.2.7.34 Inter-system measurement event results (FFS)

This IE contains the measurement event results that are reported to UTRAN for inter-system measurements. The further division of this IE into parameters is FFS.

10.2.7.35 Traffic volume measurement event results

Contains the event result for a traffic volume measurement.

Information Element/Group name	Presence	Range	IE type and reference	Semantics description
Transport CH ID	M			

10.2.7.36 Quality measurement event results (FFS)

(Note: Only the section is made.)

10.2.7.37 Measured results

Contains the measured results of the quantity indicated optionally by Reporting Quantity in Measurement Control. "Measured results" can be used for both event trigger mode and periodical reporting mode.

Information Element/Group name	Presence	Range	IE type and reference	Semantics description
RB ID + RLC buffers payload	O			
PCCPCH Info + Primary CCPCH RX E_c/I_0	O			
PCCPCH Info + Primary CCPCH RX SIR (RSCP/ISCP)	O			FFS
PCCPCH Info + Primary CCPCH RX power (RSCP)	O			FFS
PCCPCH Info + Path loss	O			FFS
PCCPCH Info + Path loss plus UL load	O			FFS
PCCPCH Info + Measured time difference to cell	O			
DL Transport CH BLER	O			
DL Transport CH BER	O			FFS
UE Transmission Power	O			UE transmission power (FDD)
T_x Power	O	0 to <maxUsed UplTScout >		UE transmission power for each used timeslot (TDD)
UE Position	O			
Cell ID	O			FFS
GSM Cell ID + measured time difference to cell	O			
GSM Cell ID + RSSI on BCCH carrier				
CHOICE <i>mode</i>				
TDD				
DL CCTrCH SIR		0 to <maxCCTr CHcount>		SIR measurements for each DL CCTrCH
Timeslot		0 to <maxTS perCCTrCH count		All timeslots on which the CCTrCH is mapped on
R_x ISCP	O			
R_x RSCP	O			
DL Timeslot ISCP		0 to <maxTS toMEASUR E count>		ISCP measurements for each timeslot indicated by the UTRAN
R_x ISCP	O			

Range Bound	Explanation
<i>MaxCCTrCHcount</i>	Maximum number of DL CCTrCH allocated to an UE
<i>MaxTSperCCTrCHcount</i>	Maximum number of TS on which a single DL CCTrCH is mapped on
<i>maxTStoMEASUREcount</i>	Maximum number of TS on which the UE has to measure
<i>maxUsedUplTScout</i>	Maximum number of TS used for UL transmissions

10.2.7.38 SFN Measurement Indicator

Indicates whether the UE should read cell SFN of the target neighbour cell or not.

10.2.7.39 Maximum number of reported cells on RACH

Information Element/Group name	Presence	Range	IE type and reference	Semantics description
Number of reported cells	M		Enumerated (no report, current cell, current cell + best neighbour, current cell+2 best neighbours, ..., current cell+6 best neighbours)	

10.2.7.40 Inter-frequency SET UPDATE (FDD only)

Contains the changes of the active set associated with a non-used frequency. This information makes it possible to use events defined for Intra-frequency measurement within the same non-used frequency for Inter-frequency measurement reporting criteria.

Information Element/group name	Presence	Range	IE type and reference	Semantics description
Radio link addition information		0 to <MaxAddRLcount>		Radio link addition information required for each RL to add
CPICH info	M			Note 1
Radio link removal information		0 to <MaxDelRLcount>		Radio link removal information required for each RL to remove
CPICH info	M			Note 1

Range bound	Explanation
<i>MaxAddRLcount</i>	Maximum number of radio links which can be added
<i>MaxDelRLcount</i>	Maximum number of radio links which can be removed/deleted

Note 1: If it is assumed that CPICH downlink scrambling code is always allocated with sufficient reuse distances, CPICH downlink scrambling code will be enough for designating the different radio links.

10.2.8 Other Information elements

10.2.8.1 BCCH modification info

Indicates modification of the System Information on BCCH.

Information Element/Group name	Presence	Range	IE type and reference	Semantics description
MIB Value tag	M		Value tag	

10.2.8.2 Inter-system message

This Information Element contains one or several messages that are structured and coded according to the specification used for the system type indicated by the first parameter.

Information Element/Group name	Presence	Range	IE type and reference	Semantics description
System type	M		Enumerated (GSM,1..15)	
Message(s)	M	1..<maxInterSysMessages>	Bitstring (1..512)	Formatted and coded according to specification for the indicated system type.

Range Bound	Explanation
<i>MaxInterSysMessages(=4)</i>	Maximum number of Inter System Messages to send

10.2.8.3 Segment index

Each system information segment has an individual segment index.

Information Element/Group name	Presence	Range	IE type and reference	Semantics description
Segment index	M		Integer (0..31)	Segments of a system information block are numbered starting with 0 for the first part.

10.2.8.4 SIB data

Contains the result of the IE 'SIB Content' after segmentation.

Information Element/Group name	Presence	Range	IE type and reference	Semantics description
SIB data	M		Bit string (size (1..MaxLength))	

It is an acceptable constraint that the 'SIB data' fills always the transport block when appearing as the last IE in a transport block.

10.2.8.5 SI Padding

Information Element/Group name	Presence	Range	IE type and reference	Semantics description
Padding	M		Bit string (size (1..MaxLength))	

All the bits of the 'SI Padding' IE shall be set to a fixed value in emission. However, it is not an error for the receiver to receive any other value for those bits.

10.2.8.6 SIB type

The SIB type identifies a specific system information block.

Information Element/Group name	Presence	Range	IE type and reference	Semantics description
SIB type	M		Enumerated	

The list of value to encode are :

Master information block,
 System Information Type 1,
 System Information Type 2,
 System Information Type 3,
 System Information Type 4,
 System Information Type 5,
 System Information Type 6,
 System Information Type 7
 System Information Type 8,
 System Information Type 9,
 System Information Type 10,
 System Information Type 11,
 System Information Type 12

10.2.8.7 Value tag

Information Element/Group name	Presence	Range	IE type and reference	Semantics description
Value tag	M		Enumerated (1..256)	

10.2.8.8 Expiration time

Information Element/Group name	Presence	Range	IE type and reference	Semantics description
Expiration time	M		Integer (0..31)	The time is expressed in seconds. Expiration time of zero means the UE has to re-read the information upon each usage occasion.

10.2.8.9 Scheduling information

Information Element/Group name	Presence	Range	IE type and reference	Semantics description
SIB type	M			
Value tag	C - Blocktype			The value of the 'value tag' IE in the 'scheduling information' IE indicates the value of the 'value tag' IE of the next occurrence of the SIB of SIB type the value of the 'SIB type' IE within the area scope of that SIB.
Scheduling	O			
> SEG_COUNT	O		SEG_COUNT	
> SIB_REP	M		Integer (16, 32, 64, 128, .. 2048)	Repetition period for the SIB in frames
> SIB_POS	M		Integer (0...Rep-1)	Position of the first segment
> SIB_POS offset info	O			
>> SIB_OFF	M	Segcount-1	Integer (1..32)	Offset of subsequent segments

Condition	Explanation
<i>Blocktype</i>	The presence of this IE depends on the value of the preceding SIB type. This IE is mandatory if the specification of the SIB of that SIB type includes as first IE a Value tag IE.

Option	Default value
SIB_POS offset info	If the SIB_POS offset info is not present, the receiver shall understand that all segments are consecutive, i.e., that the SIB_OFF would have been 0, 1, 2, ...
SEG_COUNT	If not present, the number of segments is one.
Scheduling	If not present, the SIB is not sent in the area scope.

Range Bound	Explanation
Segcount	The value of the SEG_COUNT IE
Rep	The value of the SIB_REP IE

10.2.8.10 SEG COUNT

SEG_COUNT	M		Integer (1..32)	Number of segments in the system information block
-----------	---	--	-----------------	--

11 Message and Information element abstract syntax (with ASN.1)

This chapter contains definitions for RRC PDUs and IEs using a subset of ASN.1 as specified in I2.01. PDU and IE definitions are grouped into separate ASN.1 modules.

Note that the proposal is to keep both chapter 10 and 11 (at least until all messages and information elements are fully discussed and agreed by 3GPP RAN WG2). Chapter 10 is intended to give an abstract description (in English) of the messages and information elements whereas chapter 11 should contain the exact normative definitions with all necessary details.

12 Message transfer syntax

Transfer syntax for RRC PDUs is derived from their abstract syntax definitions by use of encoding rules.

13 Protocol timers, counters and other parameters

13.1 Timers for UE

Timer	Value Range (seconds)	Relations	Start	Stop	At expiry
T300			Transmission of RRC CONNECTION REQUEST	Reception of RRC CONNECTION SETUP	Retransmit RRC CONNECTION REQUEST if $V300 \leq N300$, else go to Idle mode
T301			Transmission of RRC CONNECTION REESTABLISHMENT REQUEST	Reception of RRC CONNECTION REESTABLISHMENT	Retransmit RRC CONNECTION REESTABLISHMENT REQUEST if $V301 \leq N301$, else go to Idle mode
T302			Transmission of CELL UPDATE	Reception of CELL UPDATE CONFIRM	Retransmit CELL UPDATE if $V302 \leq N302$, else, go to Idle mode
T303			Transmission of URA UPDATE	Reception of URA UPDATE CONFIRM	Retransmit URA UPDATE if $V303 \leq N303$, else go to Idle mode
T304			Transmission of UE CAPABILITY INFORMATION	Reception of UE CAPABILITY INFORMATION CONFIRM	Retransmit UE CAPABILITY INFORMATION if $V304 \leq N304$, else initiate RRC connection reestablishment
T305			Entering CELL_FACH or CELL_PCH state. Reception of CELL UPDATE CONFIRM.	Entering another state.	Transmit CELL UPDATE.

Timer	Value Range (seconds)	Relations	Start	Stop	At expiry
T306			Entering URA_PCH state. Reception of URA UPDATE CONFIRM.	Entering another state.	Transmit URA UPDATE.
T307			When the timer T305 or T306 has expired and the UE detects that it is out of service area.	When the UE detects that it is no longer out of service area. Initiate cell update or URA update procedure depending on state	Transit to idle mode
T308			Transmission of RRC CONNECTION RELEASE COMPLETE	Not stopped	Transmit RRC CONNECTION RELEASE COMPLETE if $V308 \leq N308$, else go to idle mode.
T309			Upon reselection of a cell belonging to another radio access system from connected mode	Successful establishment of a connection in the new cell	Resume the connection to UTRAN
T310			Transmission of PUSCH CAPACITY REQUEST	Reception of PHYSICAL SHARED CHANNEL ALLOCATION	Transmit PUSCH CAPACITY REQUEST if $V310 \leq N310$, else procedure stops.
T311			Reception of PHYSICAL SHARED CHANNEL ALLOCATION message with the parameter PUSCH Allocation Pending'set to pending''	Reception of PHYSICAL SHARED CHANNEL ALLOCATION message with parameter PUSCH Allocation Pending'set to not pending''	UE may initiate a PUSCH capacity request procedure.

13.2 Timers for UTRAN

Timer	Value range (seconds)	Relations	Start	Stop	At expiry
T350		SIB_REP ¹ Activation time ²	Transmission of RRC CONNECTION SETUP	Reception of RRC CONNECTION SETUP COMPLETE	Release UE context if no RRC CONNECTION RE-ESTABLISHMENT REQUEST received
T352		SIB_REP Activation time	Transmission of RRC CONNECTION RE-ESTABLISHMENT	Reception of RRC CONNECTION RE-ESTABLISHMENT COMPLETE	Release UE context
T353		SIB_REP Activation time	Transmission of RADIO BEARER SETUP	Reception of RADIO BEARER SETUP COMPLETE or RADIO BEARER SETUP FAILURE	Release UE context if no RRC CONNECTION RE-ESTABLISHMENT REQUEST received
T354		SIB_REP Activation time	Transmission of RADIO BEARER RELEASE	Reception of RADIO BEARER RELEASE COMPLETE or RADIO BEARER RELEASE FAILURE	Release UE context if no RRC CONNECTION RE-ESTABLISHMENT REQUEST received
T355		SIB_REP Activation time	Transmission of RADIO BEARER RECONFIGURATION	Received RADIO BEARER RECONFIGURATION COMPLETE or RADIO BEARER RECONFIGURATION FAILURE	Release UE context if no RRC CONNECTION RE-ESTABLISHMENT REQUEST received
T356		SIB_REP Activation time	Sent TRANSPORT CHANNEL RECONFIGURATION	Received TRANSPORT CHANNEL RECONFIGURATION COMPLETE or TRANSPORT CHANNEL RECONFIGURATION FAILURE	Release UE context if no RRC CONNECTION RE-ESTABLISHMENT REQUEST received
T357		SIB_REP Activation time	Sent PHYSICAL CHANNEL RECONFIGURATION	Received PHYSICAL CHANNEL RECONFIGURATION COMPLETE or PHYSICAL CHANNEL RECONFIGURATION FAILURE	Release UE context if no RRC CONNECTION RE-ESTABLISHMENT REQUEST received

¹ SIB_REP is the repetition of a System Information Block (SIB)). If a specific SIB has to be read prior to transmission of a COMPLETE message from the UE this timer should be set to at least SIB_REP to ensure the UE can read the SIB.

² This timer should be set to value so it expires after the used activation time for this procedure, if any

Timer	Value range (seconds)	Relations	Start	Stop	At expiry
T358		Activation time	Sent HANDOVER COMMAND	Received HANDOVER COMPLETE or HANDOVER FAILURE	Release UE context if no RRC CONNECTION RE-ESTABLISHMENT REQUEST received
T359			Sent INTER-SYSTEM HANDOVER COMMAND	Successful handover to other radio access system or received INTER-SYSTEM HANDOVER FAILURE	Release UE context if no RRC CONNECTION RE-ESTABLISHMENT REQUEST received

13.3 Counters for UE

Counter	Reset	Incremented	When reaching max value
V300	When initiating the procedure RRC connection establishment	Upon expiry of T300.	When $V300 > N300$, the UE enters idle mode.
V301	When initiating the procedure RRC connection reestablishment	Upon expiry of T301.	When $V301 > N301$, the UE enters idle mode.
V302	When initiating the procedure Cell update	Upon expiry of T302	When $V302 > N302$ the UE enters idle mode.
V303	When initiating the procedure URA update	Upon expiry of T303	When $V302 > N303$ the UE enters idle mode.
V304	When sending the first UE CAPABILITY INFORMATION message.	Upon expiry of T304	When $V304 > N304$ the UE initiates the RRC connection re-establishment procedure

Counter	Reset	Decrementd	When reaching zero
V308	When sending the first RRC CONNECTION RELEASE COMPLETE message in a RRC connection release procedure.	Upon expiry of T308	When $V308 = 0$ the UE stops re-transmitting the RRC CONNECTION RELEASE COMPLETE message.

Counter	Reset	Incremented	When reaching max value
---------	-------	-------------	-------------------------

V310	When sending the first PUSCH CAPACITY REQUEST message in a PUSCH capacity request procedure	Upon expiry of T310	When $V310 > N310$ the UE stops re-transmitting the PUSCH CAPACITY REQUEST message.
------	---	---------------------	---

13.4 Counters for UTRAN

Counter	Reset	Incremented	When reaching max value

13.5 UE constants and parameters

Constant	Value	Usage
N300		Maximum number of retransmissions of the RRC CONNECTION REQUEST message
N301		Maximum number of retransmissions of the RRC CONNECTION REESTABLISHMENT REQUEST message
N302		Maximum number of retransmissions of the CELL UPDATE message
N303		Maximum number of retransmissions of the URA UPDATE message
N304		Maximum number of retransmissions of the UE CAPABILITY INFORMATION message
N310		Maximum number of retransmission of the PUSCH CAPACITY REQUEST message

13.6 UTRAN constants and parameters

Constant	Value	Usage

14 Specific functions

14.1 Intra-frequency measurements

14.1.1 Intra-frequency measurement quantities

1. Downlink E_c/I_0 (chip energy per total received channel power density)

2. Downlink path loss. (FFS)
3. Downlink received signal code power (RSCP) after despreading. (FFS)
4. Downlink signal-to-interference ratio (SIR) after despreading on a specific DL physical channel (RSCP/ISCP).(FFS)
5. Averaged signal-to-interference ratio (SIR) for all DL codes belonging to one TS and to one CCTrCH
6. ISCP measured on Timeslot basis

14.1.2 Intra-frequency reporting events for FDD

Within the measurement reporting criteria field in the Measurement Control message the UTRAN notifies the UE which events should trigger a measurement report. Examples of intra-frequency reporting events that would be useful for intra-frequency handover evaluation are given below. Note that normally the UEs do not need to report all these events. The listed events are the toolbox from which the UTRAN can choose the reporting events that are needed for the implemented handover evaluation function, or other radio network functions.

All the illustrated events are measured with respect to any of the measurement quantities given in section 14.1.1. The measurement objects are the monitored primary common pilot channels (CPICH). The reporting events are marked with vertical arrows in the figures below.

[Note: The events below are numbered 1A, 1B, 1C,... since all intra-frequency reporting events would be labeled 1X, inter-frequency reporting events would be labeled 2X, and so on for the other measurement types.]

14.1.2.1 Reporting event 1A: A Primary CPICH enters the reporting range

When event 1A is ordered by UTRAN in a measurement control message, the UE shall send a measurement report when a primary CPICH enters the reporting range as defined by the following formula:

$$10 \cdot \text{Log}M_{New} \geq S \cdot 10 \cdot \text{Log} \left(\sum_{i=1}^{N_A} M_i \right) + (1-S) \cdot 10 \cdot \text{Log}M_{Best} - (R + H_{1a}),$$

The variables in the formula are defined as follows:

M_{New} is the measurement result of the cell entering the reporting range.

M_i is a measurement result of a cell in the active set.

N_A is the number of cells in the current active set.

M_{Best} is the measurement result of the strongest cell in the active set.

S is a parameter sent from UTRAN to UE.

R is the reporting range

H_{1a} is the hysteresis parameter for the event 1a.

The addition window of cells in event 1A is configured with the **reporting range** parameter (R) common to many reporting events and an optional **hysteresis** parameter (H_{1a}), which can be used to distinguish the addition window from reporting windows related to other measurement events.

The occurrence of event 1A is conditional on a **report deactivation threshold** parameter. This parameter indicates the maximum number of cells allowed in the active set for measurement reports to be triggered by event 1A to be transmitted.

Event 1A may be enhanced with an addition timer, which is configured with the **time-to-trigger** parameter (see section 14.1.4.2). If a time-to-trigger value is used, a cell must continuously stay within the reporting range for the given time period, before the UE shall send a measurement report.

[Note: It is FFS, whether the cells triggering event 1A may be in the active set.]

14.1.2.2 Reporting event 1B: A primary CPICH leaves the reporting range

When this event is ordered by UTRAN in a measurement control message, the UE shall send a measurement report when a primary CPICH leaves the reporting range as defined by the following formula:

$$10 \cdot \text{Log}M_{Old} \leq S \cdot 10 \cdot \text{Log} \left(\sum_{i=1}^{N_A} M_i \right) + (1-S) \cdot 10 \cdot \text{Log}M_{Best} - (R + H_{1b}),$$

The variables in the formula are defined as follows:

M_{Old} is the measurement result of the cell leaving the reporting range.

M_i is a measurement result of a cell in the active set.

N_A is the number of cells in the current active set.

M_{Best} is the measurement result of the strongest cell in the active set.

S is a parameter sent from UTRAN to UE.

R is the reporting range

H_{1b} is the hysteresis parameter for the event 1b.

The drop window of cells in event 1B is configured with the **reporting range** parameter (R) common to many reporting events and an optional **hysteresis** parameter (H_{1b}), which can be used to distinguish the drop window from reporting windows related to other measurement events.

Event 1B may be enhanced with a drop timer, which is configured with the **time-to-trigger** parameter. If the timer is used, the weakening cell must continuously stay below the reporting range for the given time period before the UE may send a measurement report.

[Note: It is FFS whether cells triggering event 1B may belong to the monitored set cells, which are currently not in the active set]

14.1.2.3 Reporting event 1C: A non-active primary CPICH becomes better than an active primary CPICH

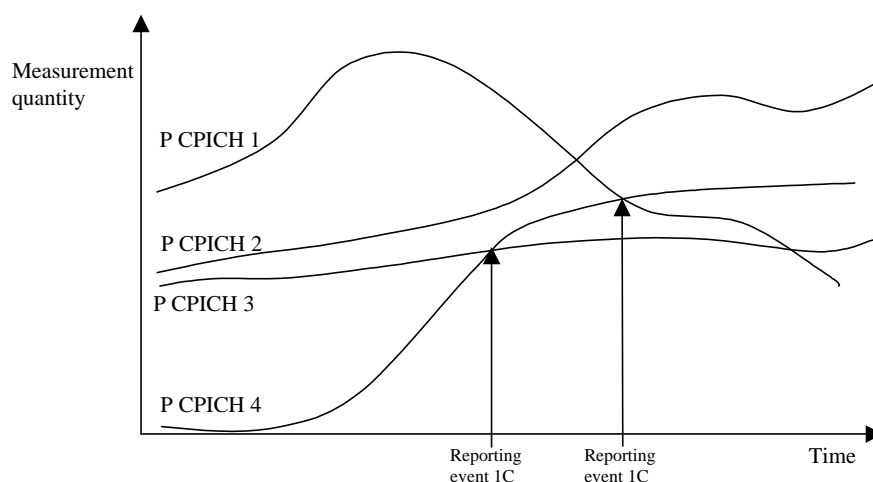

Figure 5287 A primary CPICH that is not included in the active set becomes better than a primary CPICH that is in the active set.

In this example the cells belonging to primary CPICH 1, 2 and 3 are supposed to be in the active set, but the cell transmitting primary CPICH 4 is not (yet) in the active set.

If a primary CPICH that is not included in the active set becomes better than a primary CPICH that is in the active set,

and event 1C has been ordered by UTRAN, this event shall trigger a report to be sent from the UE.

This event may be used for replacing cells in the active set. It is activated if the number of active cells is equal to or greater than a **replacement activation threshold** parameter that UTRAN signals to the UE in the MEASUREMENT CONTROL message. This parameter indicates the minimum number of cells required in the active set for measurement reports triggered by event 1C to be transmitted.

14.1.2.4 Reporting event 1D: Change of best cell

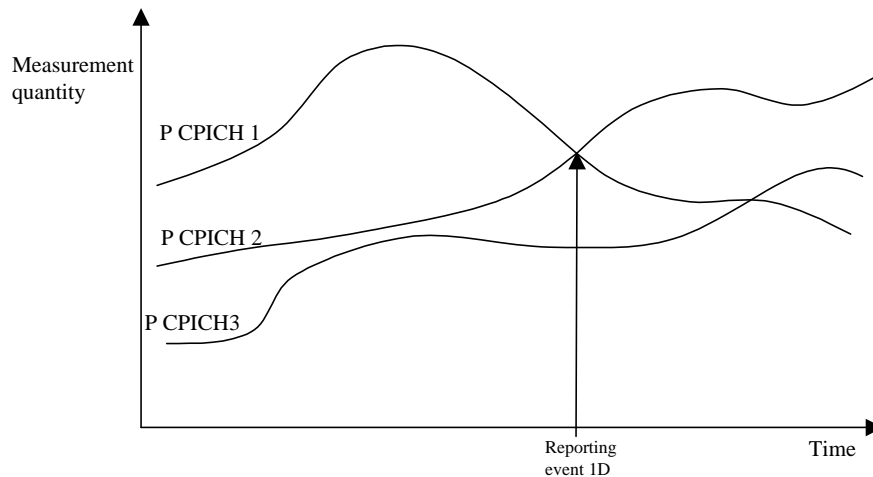

Figure 5388 A primary CPICH becomes better than the previously best primary CPICH.

If any of the primary CPICHs within the reporting range becomes better than the previously best primary CPICH, and event 1D has been ordered by UTRAN then this event shall trigger a report to be sent from the UE. The corresponding report contains (at least) the new best primary CPICH.

14.1.2.5 Reporting event 1E: A Primary CPICH becomes better than an absolute threshold

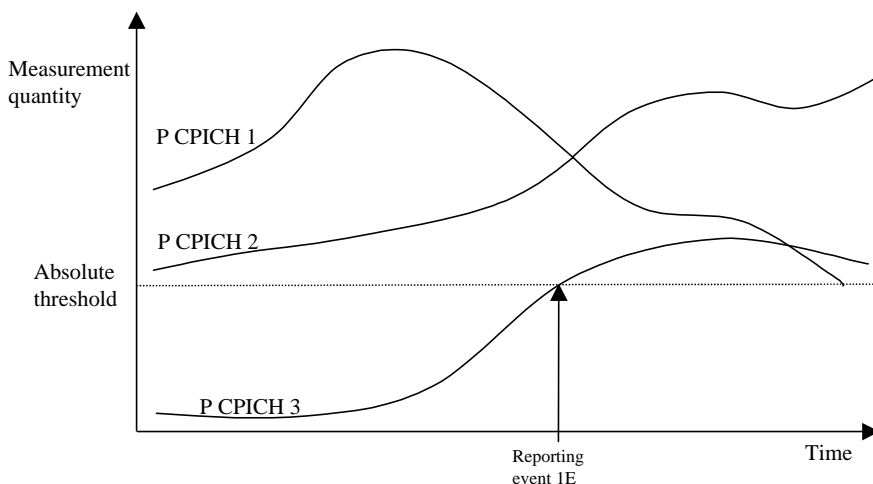

Figure 5489 Event-triggered report when a Primary CPICH becomes better than an absolute threshold.

When this event is ordered by UTRAN in a measurement control message the UE shall send a report when the Measurement quantity of a Primary CPICH becomes better than an absolute threshold. The corresponding report contains (at least) the involved Primary CPICH.

14.1.2.6 Reporting event 1F: A Primary CPICH becomes worse than an absolute threshold

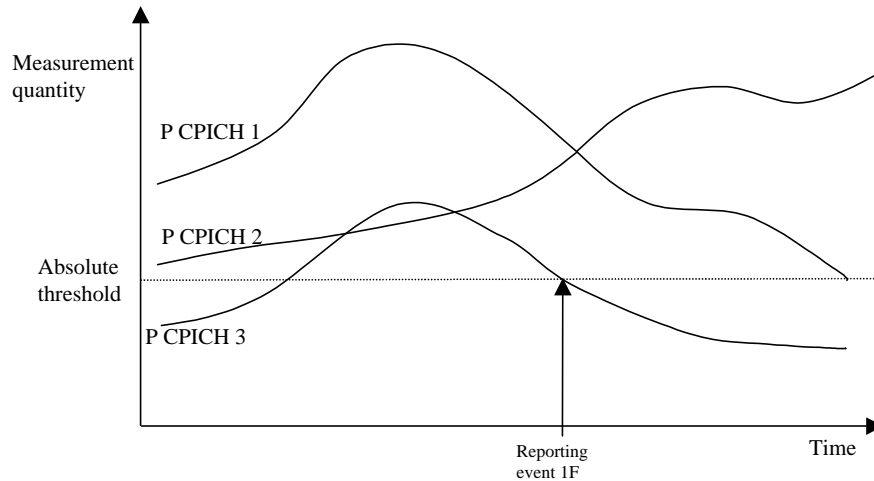

Figure 5590 Event-triggered report when a Primary CPICH becomes worse than an absolute threshold.

When this event is ordered by the UTRAN in a measurement control message the UE shall send a report when a primary CPICH becomes worse than an absolute threshold. The corresponding report contains (at least) the involved Primary CPICH.

14.1.3 Intra-frequency reporting events for TDD

14.1.3.1 Change of best cell

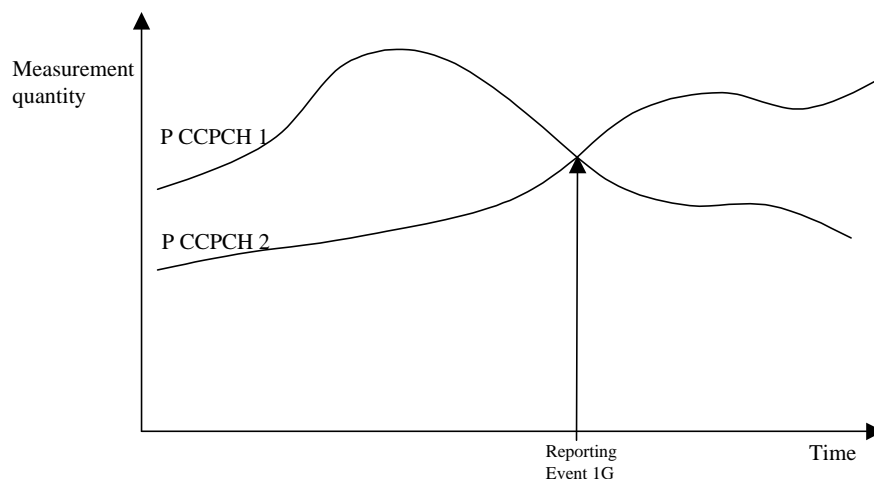

Figure 5691 A primary CCPCH becomes better than the previous best primary CCPCH

If any of the primary CCPCHs becomes better than the previously best primary CCPCH, and event 1G has been ordered by UTRAN then this event shall trigger a report to be sent from the UE. The corresponding report contains (at least) the new best primary CCPCH.

14.1.3.2 DL CCTrCH SIR below a certain threshold

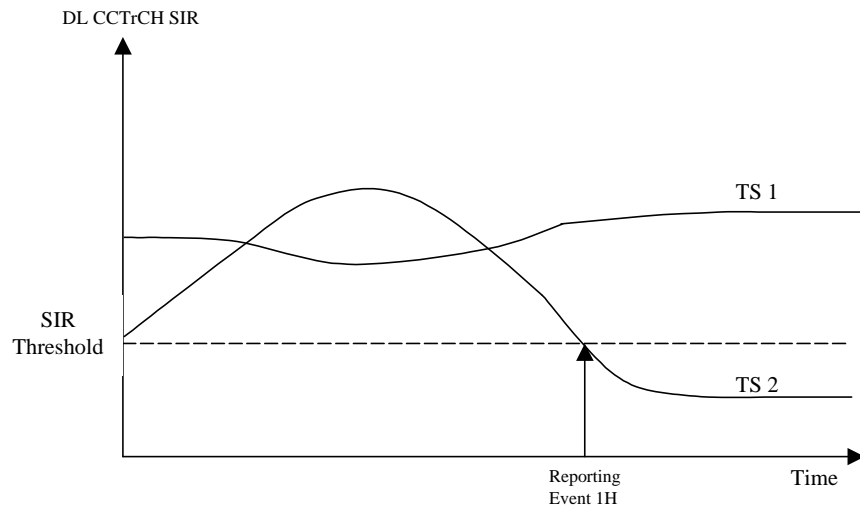

Figure 5792 A SIR value of a timeslot becomes worse than an absolute threshold

14.1.3.3 DL Timeslot ISCP below a certain threshold

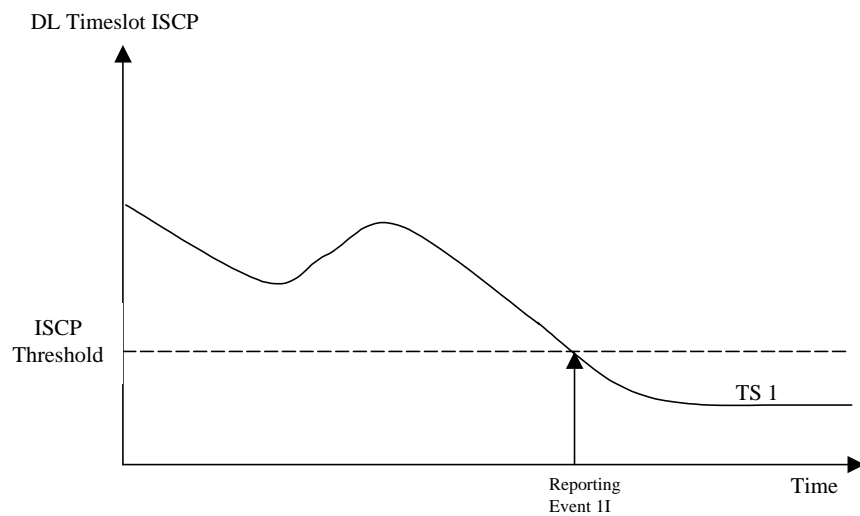

Figure 5893 A ISCP value of a timeslot becomes worse than an absolute threshold

14.1.3.4 DL Timeslot ISCP above a certain threshold

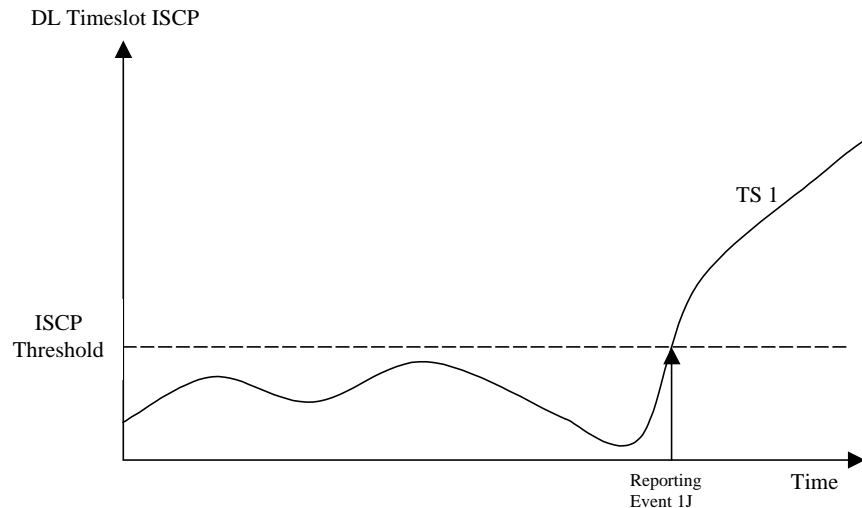

Figure 5994 A ISCP value of a timeslot becomes better than a certain threshold

14.1.4 Event-triggered periodic intra-frequency measurement reports

14.1.4.1 Cell addition failure (FDD only)

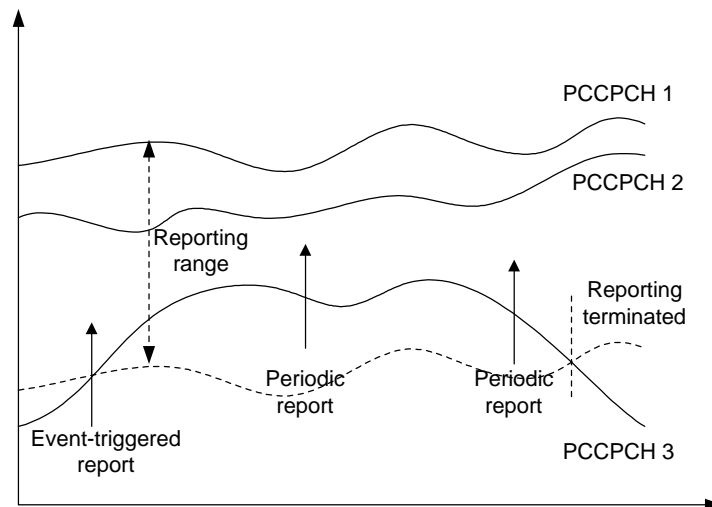

Figure 6095 Periodic reporting triggered by event 1A

When a cell enters the reporting range and triggers event 1A, the UE shall transmit a MEASUREMENT REPORT to the UTRAN and typically this may result in an update of the active set. However, in some situations the UTRAN may be unable to add a strong cell to the active set typically due to capacity shortage for example.

The UE shall continue reporting after the initial report by reverting to periodical measurement reporting if the reported cell is not added to the active set. This is illustrated in Figure 6095. During periodic reporting the UE shall transmit MEASUREMENT REPORT messages to the UTRAN at predefined intervals. The reports shall include reporting information of the cells in the current active set and of the monitored cell(s) in the reporting range.

Event-triggered periodic measurement reporting shall be terminated either when there are no longer any monitored cell(s) within the reporting range or when the UTRAN has added cells to the active set so that it includes the maximum number of cells (defined by the **reporting deactivation threshold** parameter), which are allowed for event 1A to be triggered.

The reporting period is assigned by the UTRAN. If the reporting period is set to zero event-triggered measurement reporting shall not be applied.

<Editors note: The figure should be updated to reflect that the measurements are made on the CPICH rather than PCCPCH>

14.1.4.2 Cell replacement failure (FDD only)

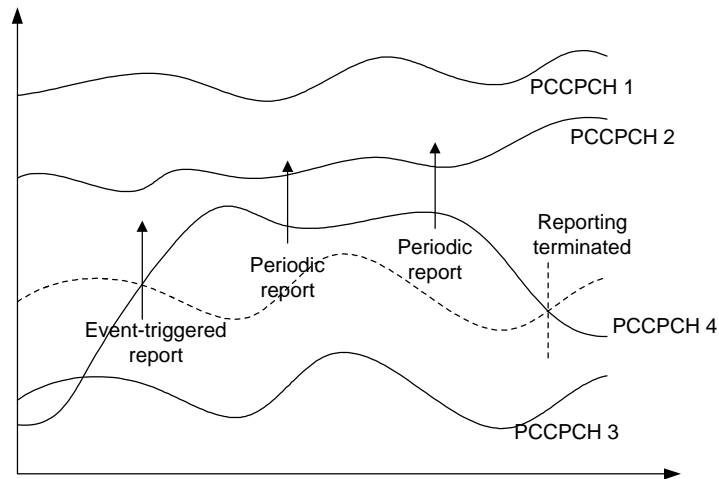

Figure 6196 Periodic reporting triggered by event 1C

When a cell enters the replacement range and triggers event 1C, the UE shall transmit a MEASUREMENT REPORT to the UTRAN and typically this may result in the replacement of the weakest active cell. If the UTRAN is unable to replace the cell due to for example capacity shortage, it is beneficial to receive continuous reports in this case as well.

The UE shall revert to periodical measurement reporting if the UTRAN does not update the active set after the transmission of the measurement report. This is illustrated in Figure 61 Figure 96. During periodic reporting the UE shall transmit MEASUREMENT REPORT messages to the UTRAN at predefined intervals. The reports shall include reporting information of the cells in the current active set and of the monitored cell(s) in the replacement range.

Event-triggered periodic measurement reporting shall be terminated either when there are no longer any monitored cell(s) within the replacement range or when the UTRAN has removed cells from the active set so that there are no longer the minimum amount of active cells for event 1C to be triggered (as defined by the **replacement activation threshold** parameter).

The reporting period is assigned by the UTRAN. If the reporting period is set to zero, event-triggered measurement reporting shall not be applied.

<Editors note: The figure should be updated to reflect that the measurements are made on the CPICH rather than PCCPCH>

14.1.4.3 Timeslot replacement failure (TDD only)

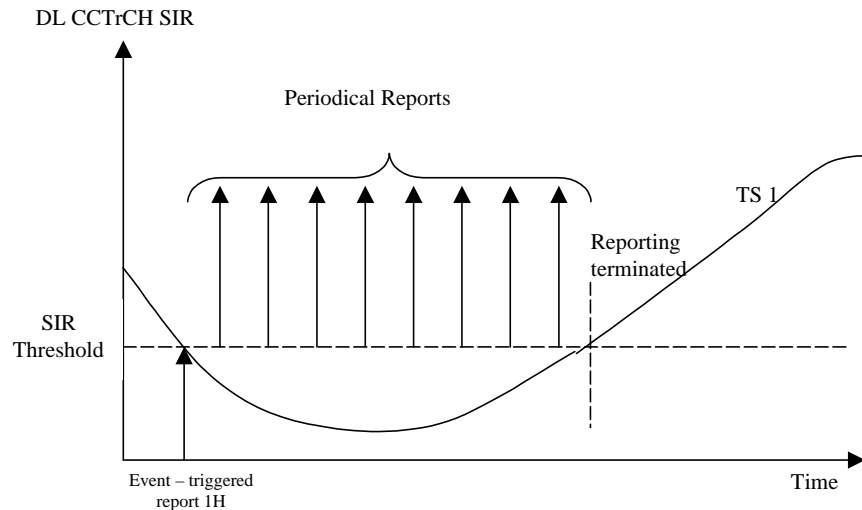

Figure 6297 Periodic reporting triggered by event 1H

When the averaged SIR value of one timeslot belonging to a DL CCTrCH triggers event 1H, the UE shall transmit a MEASUREMENT REPORT to the UTRAN and typically this may result to a change of the used downlink timeslots. However, in some situations the DCA algorithm in the UTRAN can not change the timeslots due to capacity shortage for example.

The UE shall continue reporting after the initial report by reverting to periodical measurements reporting, see Figure 5. During periodic reporting the UE shall transmit MEASUREMENT REPORT messages to UTRAN at predefined intervals. The report shall include interference measurements of selected downlink timeslots of the current cell to support the DCA algorithm.

The event-triggered periodic measurement reporting shall be terminated either when the DCA algorithm has replaced the worse downlink timeslot or when the reason for the event 1H, which has triggered the periodical measurement reporting, are not given anymore.

The reporting period is assigned by the UTRAN. IF the reporting period is set to zero event-triggered periodic measurements reporting shall not be applied.

14.1.5 Mechanisms available for modifying intra-frequency measurement reporting behaviour

14.1.5.1 Hysteresis

To limit the amount of event-triggered reports, a hysteresis parameter may be connected with each reporting event given above. The value of the hysteresis is given to the UE in the Reporting criteria field of the Measurement Control message.

In the example in [Figure 63](#)~~Figure 98~~, the hysteresis ensures that the event 1D (FDD) or IG(TDD) (primary CPICH(FDD)/CCPCH(TDD) 2 becomes the best cell) is not reported until the difference is equal to the hysteresis value. The fact that primary CPICH(FDD)/CCPCH(TDD) 1 becomes best afterwards is not reported at all in the example since the primary CPICH(FDD)/CCPCH(TDD) 1 does not become sufficiently better than the primary CPICH(FDD)/CCPCH(TDD) 2.

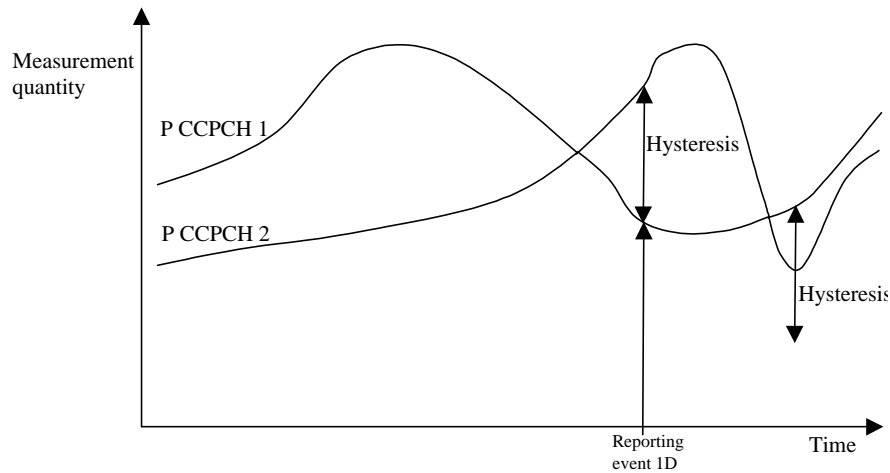

Figure 6398 Hysteresis limits the amount of measurement reports.

14.1.5.2 Time-to-trigger

To limit the measurement signalling load, a time-to-trigger parameter could be connected with each reporting event given above. The value of the time-to-trigger is given to the UE in the Reporting criteria field of the Measurement Control message.

The effect of the time-to-trigger is that the report is triggered only after the conditions for the event have existed for the specified time-to-trigger. In the following FDD example in Figure 6599, the use of time-to-trigger means that the event (primary CPICH 3 enters the reporting range) is not reported until it has been within the range for the time given by the time-to-trigger parameter.

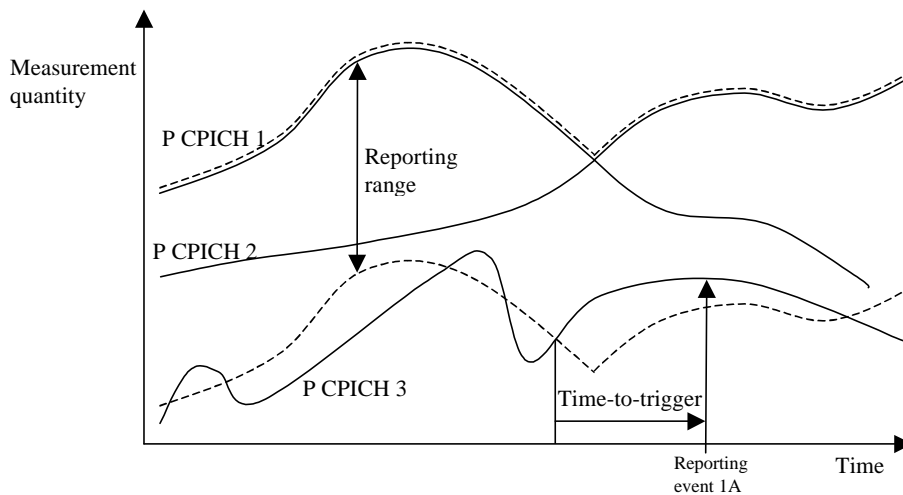

Figure 6599 Time-to-trigger limits the amount of measurement reports.

In the following TDD example in Figure 67100, the use of time-to-trigger means that the event (DL Timeslot ISCP upon certain threshold) is not reported until it has been upon the threshold for the time given by the time-to trigger parameter.

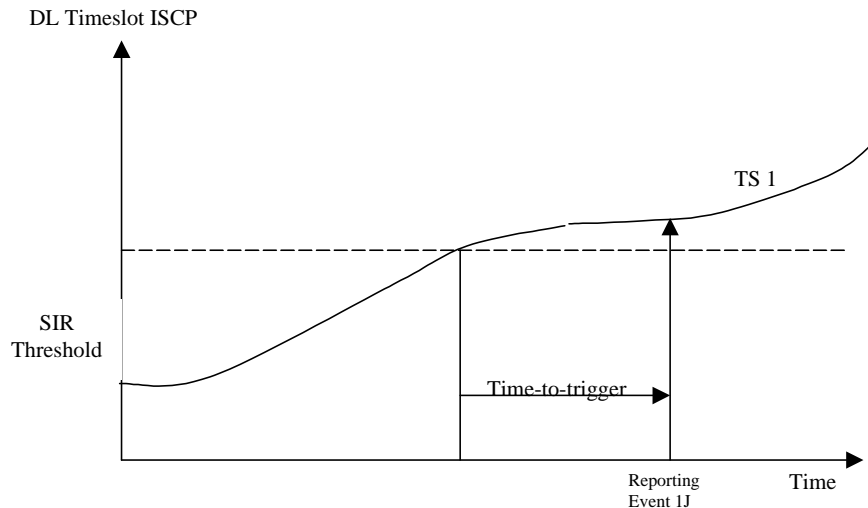

Figure 67100 Time-to-trigger limits the amount of measurement reports.

Note that the time-to-trigger could be combined with hysteresis, i.e. a hysteresis value is added to the measurement quantity before evaluating if the time-to-trigger timer should be started.

14.1.5.3 Cell individual offsets

For each cell that is monitored, an offset can be assigned with inband signalling. The offset can be either positive or negative. The offset is added to the measurement quantity before the UE evaluates if an event has occurred. The UE receives the cell individual offsets for each primary CPICH(FDD)/CCPCH(TDD) in the measurement object field of the MEASUREMENT CONTROL message.

For the FDD example, in [Figure 69Figure 101](#), since an offset is added to primary CPICH 3, it is the dotted curve that is used to evaluate if an event occurs. Hence, this means that measurement reports from UE to UTRAN are triggered when primary CPICH plus the corresponding offset, i.e. the dotted curve, leaves and enters the reporting range and when it gets better than primary CPICH 1 (if these events have been ordered by UTRAN). This offset mechanism provides the network with an efficient tool to change the reporting of an individual primary CPICH.

By applying a positive offset, as in [Figure 69Figure 101](#), the UE will send measurement reports as if the primary CPICH is offset x dB better than what it really is. This could be useful if the operator knows that a specific cell is interesting to monitor more carefully, even though it is not so good for the moment. In the example in [Figure 69Figure 101](#), the operator might know by experience that in this area primary CPICH 3 can become good very quickly (e.g. due to street corners) and therefore that it is worth reporting more intensively. Depending on the implemented handover evaluation algorithm, this may result in the cell with primary CPICH 3 being included in the active set earlier than would have been the case without the positive offset.

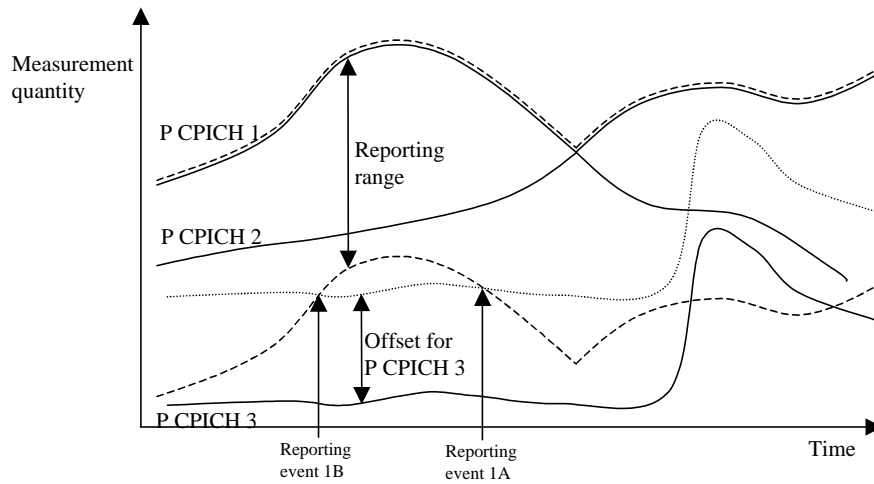

Figure 69101 A positive offset is applied to primary CPICH 3 before event evaluation in the UE.

For the TDD example, in [Figure 71102](#), an offset is added to primary CCPCH2, it is the dotted curve that is used to evaluate if the primary CCPCH2 becomes better than primary CCPCH1 (ordered by the UTRAN).

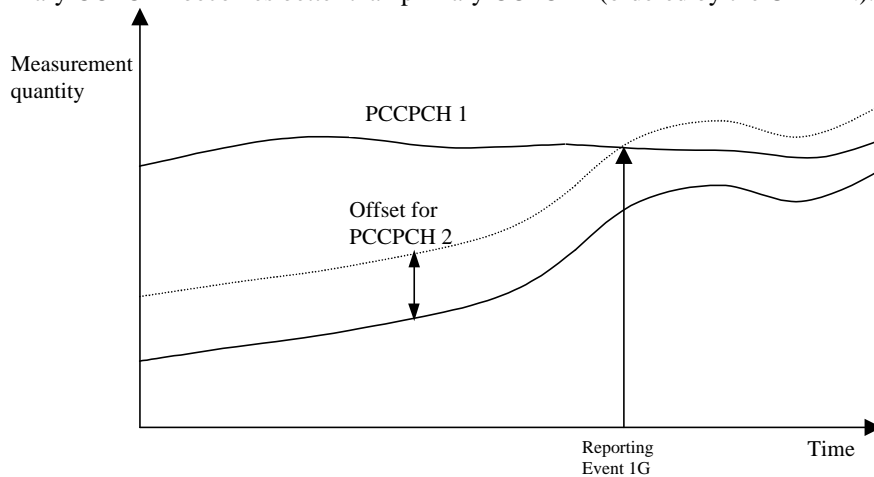

Figure 71102 A positive offset is applied to primary CCPCH 2.

Correspondingly, the operator can choose to apply a negative offset to a primary CCPCH. Then the reporting on that primary CCPCH is limited and the corresponding cell may be, at least temporarily excluded from the active set or as a target cell for handover.

The cell individual offset can be seen as a tool to move the cell border. It is important to note that the offset is added before triggering events, i.e. the offset is added by the UE before evaluating if a measurement report should be sent as opposed to offsets that are applied in the network and used for the actual handover evaluation.

14.1.5.4 Forbid a Primary CPICH to affect the reporting range (FDD only)

The reporting range affects the reporting events 1A and 1B presented above. The reporting range is defined relative to the best Primary CPICH. However, there could be cases where it is good to forbid a specific Primary CPICH to affect the reporting range. For example in [Figure 73103](#) the network has requested the UE to not let Primary CPICH 3 affect the reporting range. This mechanism could be effective if the operator knows by experience that the quality of Primary CPICH 3 is very unstable in a specific area and therefore should not affect the reporting of the other Primary CPICHs.

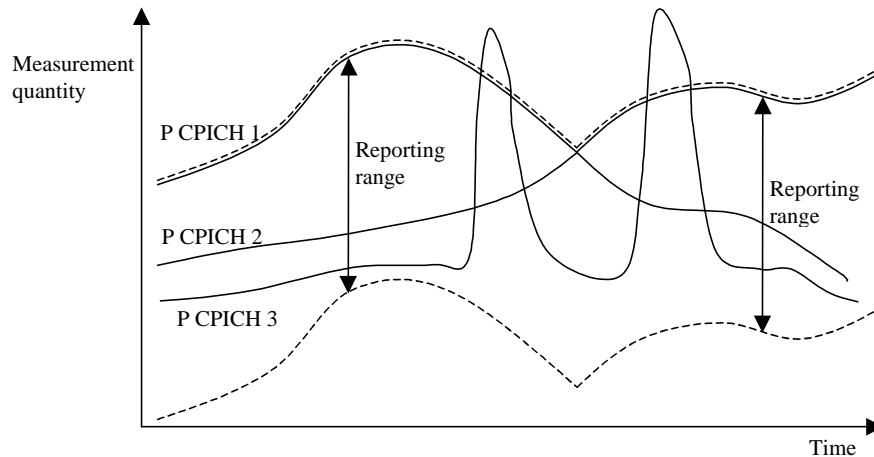

Figure 73103 Primary CPICH 3 is forbidden to affect the reporting range.

14.1.6 Report quantities

In the event-triggered measurement reports, mandatory information connected to the events is always reported. For instance, at the event 'primary CPICH(FDD)/CCPCH(TDD) enters the reporting range' the corresponding report identifies the primary CPICH(FDD)/CCPCH(TDD) that entered the range.

However, besides this mandatory information, UTRAN should be able to optionally require additional measurement information in the report to support the radio network functions in UTRAN. Furthermore, it will allow the UTRAN to use the UE as a general tool for radio network optimisation if necessary.

Examples of report quantities that may be appended to the measurement reports are:

[Note: This list is general and does also apply for reports of other measurement types than the intra-frequency type. The list is not final.]

- Downlink transport channel block error rate
- Downlink transport channel bit error rate
- Downlink E_b/I_0 on primary CPICH(FDD)/CCPCH(TDD) (e.g. used for initial DL power setting on new radio links.)
- Time difference between the received primary CPICH(FDD)/CCPCH(TDD) frame-timing from the target cell and the earliest received existing DPCH path. [Note: This measurement is identified in 25.211 [2] (denoted T_m in chapter 7)]
- UE transmit power
- UE position (FFS)
- Downlink SIR (RSCP/ISCP) on the traffic channels after RAKE combining (FFS)
- Downlink SIR (RSCP/ISCP) on primary CPICH(FDD)/CCPCH(TDD) (e.g. used for initial DL power setting on new radio links.)(FFS)

14.2 Traffic Volume Measurements

14.2.1 Traffic Volume Measurement Quantity

For traffic volume measurements in the UE only one quantity is measured. This quantity is RLC buffer payload in number of bytes. In order to support a large variation of bit rates and RLC buffer size capabilities, a non-linear scale should be used [Note: details are FFS]. Since, the expected traffic includes both new and retransmitted RLC payload

units all these should be included in the payload measure. It should also be noted that traffic volume measurements are only applicable for acknowledged and unacknowledged mode.

According to what is stated in the Measurement Control message, the UE should support measuring of buffer payload for a specific RB, RBs multiplexed onto the same Transport channel and the total UE buffer payload (the same as one transport channel for a UE that uses RACH).

14.2.2 Traffic Volume reporting events

Traffic volume can be reported in two different ways, periodical and event triggered. For periodical reporting the UE simply measures the number of bytes for the transport channel (i.e. the RLC buffers of the RBs multiplexed onto that transport channel) stated in the measurement control message and reports the traffic volume at the given time instants. Event triggered reporting is performed when a threshold is exceeded.

The reporting quantities which should be included in the report is stated in the measurement control message. This could for example be which RBs or RLC buffers to include when sending the payload to the network.

14.2.2.1 Reporting event 4 A: RLC buffer payload exceeds an absolute threshold

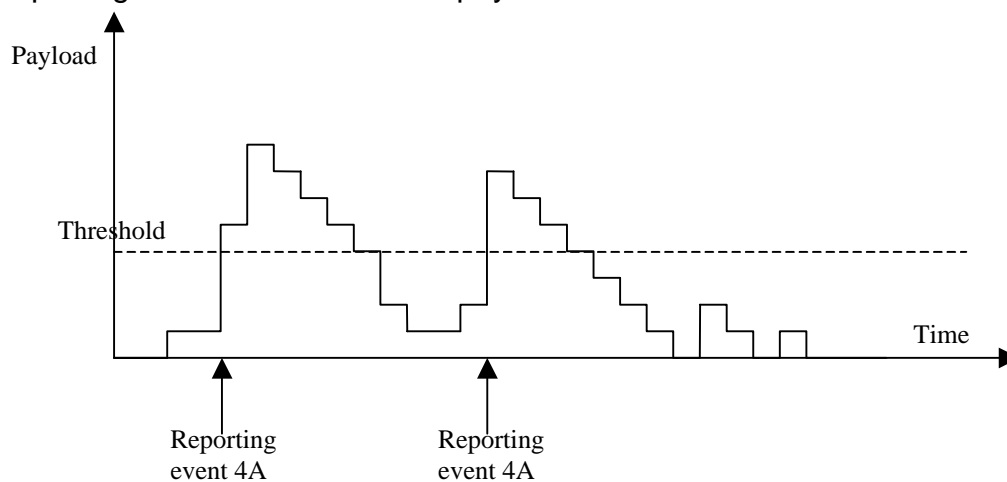

Figure 75104 Event triggered report when RLC buffer payload exceeds a certain threshold.

If the monitored payload exceeds an absolute threshold, this is an event that could trigger a report. The corresponding report contains at least which transport channel triggered the report.

14.2.3 Traffic volume reporting mechanisms

Traffic volume measurement triggering could be associated with both a *time-to-trigger* and a *pending time after trigger*. The time-to-trigger is used to get time domain hysteresis, i.e. the condition must be fulfilled during the time-to-trigger time before a report is sent. Pending time after trigger is used to limit consecutive reports when one traffic volume measurement report already has been sent. This is described in detail below.

14.2.3.1 Pending time after trigger

This timer is started in the UE when a measurement report has been triggered. The UE is then forbidden to send any new measurement reports with the same measurement ID during this time period even when the triggering condition is fulfilled again. Instead the UE waits until the timer has suspended. If the payload is still above the threshold when the timer has expired the UE sends a new measurement report. Otherwise it waits for a new triggering.

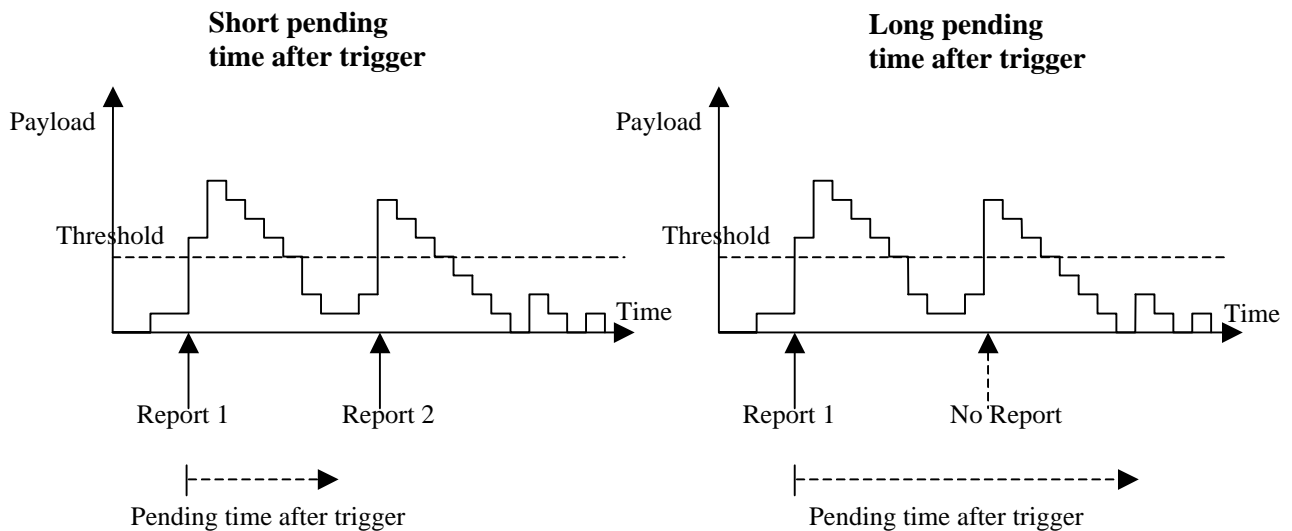

Figure 76105 Pending time after trigger limits the amount of consecutive measurement reports.

Figure 76105 shows that by increasing the pending time after trigger a triggered second event does not result in a measurement report.

14.2.4 Interruption of user data transmission

A UE in CELL_FACH substate may be instructed by the UTRAN to cease transmission of user data on the RACH after a measurement report has been triggered. Before resuming transmission of user data,

- the UE shall receive from the UTRAN either a message allocating a dedicated physical channel, and make a transition to CELL_DCH state, OR
- the UE shall receive an individually assigned measurement control message indicating that interruption of user data transmission is not be applied.

The transmission of signalling messages on the signalling bearer shall not be interrupted.

14.3 UE internal measurements

14.3.1 UE internal measurement quantities

For UE internal measurements the following measurement quantities exist:

1. UE transmission (Tx) power, for TDD measured on a timeslot basis.
2. UE received signal strength power (RSSI)

14.3.2 UE internal measurement reporting events

In the Measurement reporting criteria field in the Measurement Control messages, the UTRAN notifies the UE of which events should trigger a measurement report. UE internal measurement reporting events that can trigger a report are given below. The reporting events are marked with vertical arrows in the figures below. All events can be combined with time-to-trigger. In that case, the measurement report is only sent if the condition for the event has been fulfilled for the time given by the time-to-trigger parameter

[Note: The reporting events are numbered 6A, 6B, 6C,.. where 6 denotes that the event belongs to the type UE internal measurements.]

14.3.2.1 Reporting event 6A: The UE Tx power becomes larger than an absolute threshold

When this event is ordered by UTRAN in a measurement control message, the UE shall send a measurement report when the UE transmission power (for TDD within a single TS) becomes larger than a predefined threshold. The corresponding report identifies the threshold that was exceeded.

14.3.2.2 Reporting event 6B: The UE Tx power becomes less than an absolute threshold

When this event is ordered by UTRAN in a measurement control message, the UE shall send a measurement report when the UE transmission power (for TDD within a single TS) becomes less than a predefined threshold. The corresponding report identifies the threshold that the UE Tx power went below.

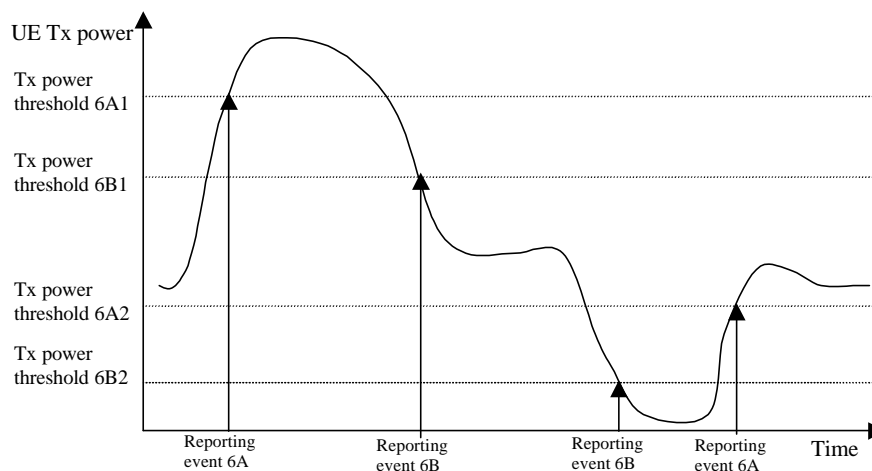

Figure 77106 Event-triggered measurement reports when the UE Tx power becomes larger or less than absolute thresholds.

14.3.2.3 Reporting event 6C: The UE Tx power reaches its minimum value

When this event is ordered by UTRAN in a measurement control message, the UE shall send a measurement report when the UE Tx power reaches its minimum value, for TDD its minimum value on a single timeslot.

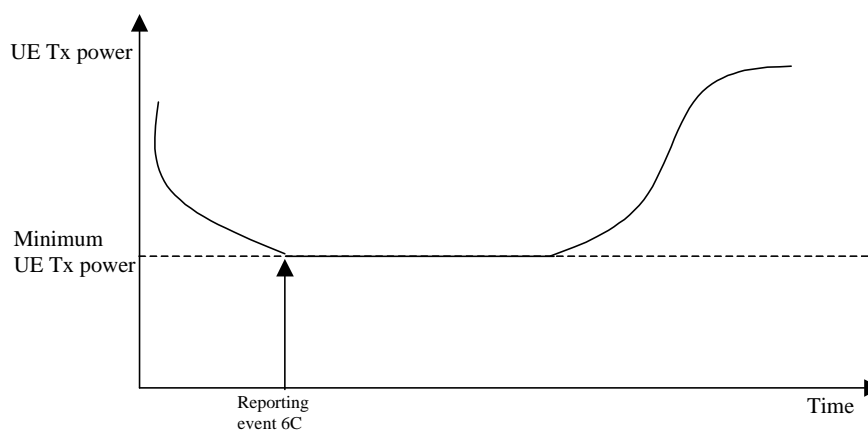

Figure 78107 Event-triggered measurement report when the UE Tx power reaches its minimum value.

14.3.2.4 Reporting event 6D: The UE Tx power reaches its maximum value

When this event is ordered by UTRAN in a measurement control message, the UE shall send a measurement report when the UE Tx power reaches its maximum value, for TDD its maximum value on a single timeslot.

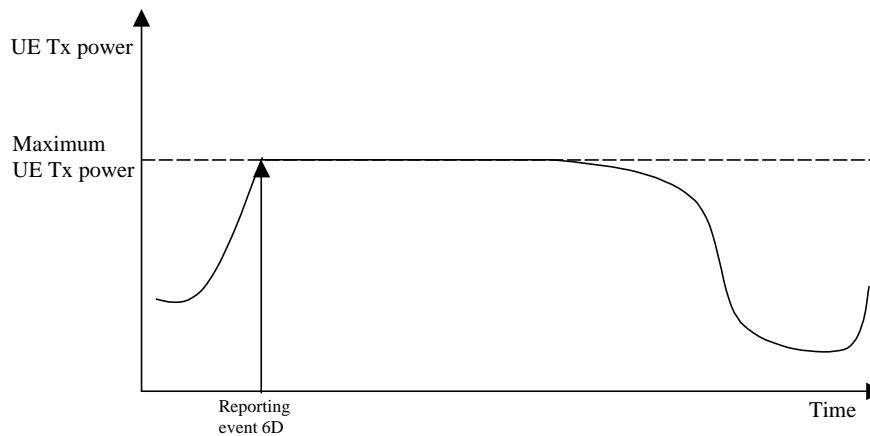

Figure 79108 Event-triggered report when the UE Tx power reaches its maximum value.

14.3.2.5 Reporting event 6E: The UE RSSI reaches the UE's dynamic receiver range

When this event is ordered by UTRAN in a measurement control message, the UE shall send a measurement report when the UE RSSI reaches the UE's dynamic receiver range.

14.4 Dynamic Resource Allocation Control of Uplink DCH (FDD only)

The network uses this procedure to dynamically control the allocation of resources on an uplink DCH, this is achieved by sending transmission probability and maximum data rate information elements.

This procedure is initiated with a SYSTEM INFORMATION message from the NW RRC and applies to all UEs having uplink DCH's that are dynamically controlled by this procedure. Such uplink DCH's could be established through RB establishment procedure, RB reconfiguration procedure, RB release procedure or Transport Channel Reconfiguration procedure by using a Dynamic Control'parameter to indicate that the DCH is controlled by the DRAC procedure.

This function is launched by UE upon reception of a SYSTEM INFORMATION message comprising DRAC parameters (ptr, Max. bit rate).

1. The UE randomly selects $p \in [0,1]$.
2. The UE then checks its permission: if $p < p_{tr}$ the permission is granted for $T_{validity}$ frames, otherwise the UE waits for T_{retry} frames before re-attempting access.
3. A new subset of TFCS is sent to MAC, according to the permission result and to maximum bit rate granted. This subset of TFCS shall only affect DCH that are controlled by this procedure.

Transmission time validity, Time duration before retry and Silent period duration before release are indicated to the UE together with the Dynamic Control'parameter (i.e. at the establishment of a DCH controlled by this procedure) and may eventually be changed through RB reconfiguration.

When the UE is in soft handover, the UE may have to listen to the CCCH system information of 1 or several cells in the Active Set in order to react to the most stringent parameters, e.g. the lowest product $ptr * \text{max bit rate}$. In case of conflict in the reception of multiple FACH, the UE shall listen to the FACH with a priority order corresponding to the rank of cells in its Active Set (i.e. the FACH of the best received cells should be listened to first).

Whether the support for DRAC function is dependent on the UE capability or UE service capability is FFS

14.5 Downlink outer loop power control

This function is implemented in the UE in order to set the Eb/No target value used for the downlink closed loop power control. This Eb/No value is set according to some quality measurements performed in the UE, in order to maintain the quality requirements (FER or BER).

The UE shall set the Eb/No within the range allocated by the RNC when the physical channel has been set up or reconfigured. It shall not increase the Eb/No target value before the closed loop power control has converged on the current value. The UE may estimate whether the closed loop power control has converged on the current value, by comparing the averaged measured Eb/No to the Eb/No target value.

If the UE has received a DL outer loop control message from UTRAN indicating that the Eb/No target value shall not be increased above the current value, it shall record the current value as the maximum allowed value for the outer loop power control function, until it receives a new DL outer loop control message from UTRAN indicating that the restriction is removed.

14.6 Calculated Transport Format Combination

The Calculated Transport Format Combination (CTFC) is a tool for efficient signalling of transport format combinations.

Let I be the number of transport channels that are included in the transport format combination. Each transport channel TrCH_i , $i = 1, 2, \dots, I$, has L_i transport formats, i.e. the transport format indicator TFI_i can take L_i values,

$$\text{TFI}_i \in \{0, 1, 2, \dots, L_i - 1\}.$$

Define $P_i = \prod_{j=0}^{i-1} L_j$, where $i = 1, 2, \dots, I$, and $L_0 = 1$.

Let $\text{TFC}(\text{TFI}_1, \text{TFI}_2, \dots, \text{TFI}_I)$ be the transport format combination for which TrCH_1 has transport format TFI_1 , TrCH_2 has transport format TFI_2 , etc. The corresponding $\text{CTFC}(\text{TFI}_1, \text{TFI}_2, \dots, \text{TFI}_I)$ is then computed as:

$$\text{CTFC}(\text{TFI}_1, \text{TFI}_2, \dots, \text{TFI}_I) = \sum_{i=1}^I \text{TFI}_i \cdot P_i.$$

14.7 Provision and reception of RRC Initialisation Information between RNCs

When relocation of SRNS is decided to be executed, the RRC shall build the state information, which contains the RRC, RLC and MAC related RRC message information elements, which currently specify the state of the RRC. This RRC INITIALISATION INFORMATION shall be sent by the source RNC to the target RNC to enable transparent relocation of the RRC and lower layer protocols. Correspondingly, the RRC in the target RNC shall receive the RRC INITIALISATION INFORMATION and update its state parameters accordingly to facilitate a transparent relocation of SRNS for the UE.

14.7.1 RRC Initialisation Information

Information Element	Presence	Range	IE type and reference	Semantics description
UE Information elements				
U-RNTI				
C-RNTI				
Power Control Capability				
Code Resource Capability				
UE Mode Capability				
Transport CH support capability				
Ciphering Capability				
Macro Diversity Capability				
FAUSCH usage support				
Inter System message (inter system classmark)				
UTRAN Mobility Information elements				
URA Identifier				
CN Information Elements				
CN Domain Identity				
NAS System Info				

Measurement Related Information elements				
For each ongoing measurement reporting				
Measurement Identity Number				
Measurement Command				
Measurement Type				
Measurement Reporting Mode				
CHOICE Measurement				
Intra-frequency				
Intra-frequency cell info				
Intra-frequency measurement quantity				
Intra-frequency measurement reporting quantity				
CHOICE report criteria				
Intra-frequency measurement reporting criteria				
Periodical reporting				
Inter-frequency				
Inter-frequency cell info				
Inter-frequency measurement quantity				
Inter-frequency measurement reporting quantity				
CHOICE report criteria				
Inter-frequency measurement reporting criteria				
Periodical reporting				
Inter-system				
Inter-system cell info				
Inter-system measurement quantity				
Inter-system measurement reporting quantity				
CHOICE report criteria				
Inter-system measurement reporting criteria				
Periodical reporting				
Traffic Volume				
Traffic volume measurement Object				
Traffic volume measurement quantity				
Traffic volume measurement reporting quantity				
CHOICE report criteria				
Traffic volume measurement reporting criteria				
Periodical reporting				
Quality				
Quality measurement Object				
Quality measurement quantity				
Quality measurement reporting quantity				
CHOICE report criteria				
Quality measurement reporting criteria				
Periodical reporting				
UE internal				
UE internal measurement quantity				
UE internal measurement				

reporting quantity				
CHOICE report criteria				
UE internal measurement reporting criteria				
Periodical reporting				
Radio Bearer Information Elements				
For each Radio Bearer				
RB Identity				
RLC Info				
RB mapping info				
Transport Channel Information Elements				
TFCS (UL DCHs)				
TFCS (DL DCHs)				
TFC subset (UL DCHs)				
For each uplink transport channel				
Transport channel identity				
TFS				
DRAC Information				
Dynamic Control				
Transmission Time validity				
Time duration before retry				
Silent Period duration before release				
For each downlink transport channel				
Transport channel identity				
TFS				
Physical Channel Information Elements				
Frequency info				
Uplink DPCH power control info				
SSDT Indicator				FFS
CPCH SET info				
Gated Transmission Control info				FFS
Default DPCH Offset value				
Uplink radio resource information				
Choice channel requirement				
Uplink DPCH info				
PRACH info (for RACH)				
PRACH info (for FAUSCH)				
Uplink Timeslot info				
Downlink Radio Resource Information				
Downlink DPCH power control info				
Downlink DPCH compressed mode info				
Downlink Information				
Primary CCPCH Info				
Downlink DPCH info				
Secondary CCPCH info				
Downlink Timeslot info				

15 Primitives between RRC and upper layers

16 Handling of unknown, unforeseen and erroneous protocol data

This section specifies procedures for the handling of unknown, unforeseen, and erroneous protocol data by the receiving entity. These procedures are called "error handling procedures".

17 SDL

This section describes the functionality of the protocol in descriptive SDL.

18 Appendices: Examples of operation

19 History

Document history		
Date	Version	Comment
January 1999	0.0.1	<p>Created following the first 3GPP WG2 meeting . Text from two documents were merged. These documents were:</p> <p>ETSI SMG2 UMTS L23 EG document: 'Description of the RRC protocol, YY.31, v0.2.0, ETSI L23EG Tdoc 065/99, January 19, 1999.</p> <p>and</p> <p>TTC/ARIB document: 'Draft UE-UTRAN L3 RRC signalling protocol', Vol. 9, Ver 1.0.0, January 14, 1999, ETSI L23 EG Tdoc 010/99</p> <p>The ETSI document was taken as the baseline document and change marks are given in v 0.0.1 of S2.31 with respect to the ETSI document.</p>
March 1999	0.0.2	Updated according to 3GPP template. There were no changes to S2.31 agreed at the January 1999 meeting
April 1999	0.1.0	Updated to include new message and information element functional descriptions as described in TSGR2#3(99)220 (report of RRC email ad-hoc). New chapter headings 10-17 have been added and Annex 1 removed. Text updated to reflect new definitions for paging messages.
April 1999	TS 25.331 V1.0.0	Noted by TSG-RAN as TS 25.331V1.0.0
May 1999	V1.0.1	Tables in Section 10 edited so that they read correctly when opened from WORD 6.0
June 1999	V1.1.0	Edited following May 1999 RAN2meeting. Includes modifications to RRC procedures agreed in RRC procedures email ad-hoc (and mostly captured in Tdoc 376). Note that new procedures on RNTI re-allocation and RRC status added. Also includes a large number of modifications to RRC parameters and information elements most of which were captured in Tdoc 380. Updated to WORD 97.
July 1999	V1.2.0	Edited following the RAN2 meeting held in July 1999. Includes changes agreed in an email discussion, these changes were in the main captured in Tdoc 525. Also includes changes agreed at the RRC ad-hoc which was held during the meeting (See Tdoc 680). A number of other changes were also agreed - see meeting minutes.

August 1999	V1.2.1	Minor editing performed prior to RAN2 meeting #6. Some alignment between 25.303 and 25.331 performed.
August 1999	V1.3.0	First draft edits performed following RAN2 meeting #6 (August 1999, Sophia Antipolis).
September 1999	V1.3.1	Includes a few minor editorials based on comments received by email
September 1999	V1.4.0	Minor edit following presentation of V1.3.1 at RAN2#7
September 1999	V1.4.1	Edited during RAN2#7 to implement the proposal contained in tdoc A51 (section 8 (RRC procedures) updated in line with new structure for procedure descriptions, section 9 (Timers, etc) replaced with substantially revised section 9 from A51, and section 13 (RRC states) moved to section 9)
September 1999	V1.4.2	Major edit following RAN2#7
September 1999	V1.4.3	Many minor edit following email comments received on V1.4.2
September 1999	V1.4.4	Changes to the traffic volume measurement quantity, reporting quantity, and reporting criteria IEs as contained in tdoc 906. Tdoc 906 was approved at WG2#6 but not incorporated into 25.331 between meeting 6 and 7.
October 1999	V1.5.0	Change bars removed and raised to version 1.5.0 for presenting to RAN#5 in Korea (as tdoc RP-99468) .

Rapporteur for TS 25.331 is:

Richard Burbidge
Motorola, UK

Tel: +44 1256 790663

Fax: +44 1256 790190

Email: Richard.Burbidge@motorola.com

This document is written using Microsoft Word 97.