

Technical Specification Group, Radio Access Network
Meeting #2, Fort Lauderdale, 2-4 March 1999

TSGR#2(99)078

Source: Editor
Title: S3.01 RAN Overall Description
Document for: Decision
Agenda Item: 7

TS S3.01 V0.0.3 (1999-02)

Technical Specification

**3rd Generation Partnership Project (3GPP);
Technical Specification Group (TSG) <name>;
RAN Overall Description
[UMTS <spec>]**

3GPP

Reference

<Workitem> (<Shortfilename>.PDF)

Keywords

<keyword[, keyword]>

3GPP

Postal address

Office address

Internet

secretariat@3gpp.org
Individual copies of this deliverable
can be downloaded from
<http://www.3gpp.org>

Copyright Notification

No part may be reproduced except as authorized by written permission.
The copyright and the foregoing restriction extend to reproduction in all media.

©
All rights reserved.

Contents

Intellectual Property Rights	8
Foreword	8
1 Scope.....	8
2 References	8
3 Definitions, symbols and abbreviations.....	8
3.1 Definitions	8
3.2 Abbreviations.....	9
3.3 Notation	10
4 General principles.....	10
5 UMTS General architecture	10
5.1 Overview.....	10
5.2 General protocols architecture	11
5.2.1 User plane	11
5.2.2 Control plane.....	12
6 UTRAN Architecture	12
7 UTRAN Functions description	13
7.1 List of functions.....	13
7.2 Functions description	14
7.2.1 Functions related to overall system access control.....	14
7.2.1.1 Admission Control.....	14
7.2.1.2 Congestion Control.....	14
7.2.1.3 System information broadcasting.....	14
7.2.2 Functions related to security and privacy	15
7.2.2.1 Use of Temporary Identifier	15
7.2.2.2 Radio channel ciphering	15
7.2.2.3 Radio channel deciphering	15
7.2.3 Functions related to handover	15
7.2.3.1 Radio environment survey.....	15
7.2.3.2 Handover decision.....	15
7.2.3.3 Macro-diversity control	16
7.2.3.4 Handover Control	16
7.2.3.5 Handover execution.....	16
7.2.3.6 Handover completion	16
7.2.3.7 SRNS Relocation.....	16
7.2.3.8 Inter-System handover	16
7.2.3.8.1 Handover from UMTS to GSM	16
7.2.3.8.2 Handover from GSM to UMTS	17
7.2.4 Functions related to radio resource management and control	17
7.2.4.1 Radio bearer connection set-up and release (Radio Bearer Control).....	17
7.2.4.2 Reservation and release of physical radio channels.....	17
7.2.4.3 Allocation and deallocation of physical radio channels.....	17
7.2.4.4 Packet data transfer over radio function	18
7.2.4.5 RF power control.....	18
7.2.4.5.1 UL OUTER LOOP POWER CONTROL.....	18
7.2.4.5.2 DL OUTER LOOP POWER CONTROL.....	18
7.2.4.5.3 UL INNER LOOP POWER CONTROL	18
7.2.4.5.4 DL INNER LOOP POWER CONTROL	18
7.2.4.5.5 UL OPEN LOOP POWER CONTROL.....	19
7.2.4.5.6 DL OPEN LOOP POWER CONTROL.....	19
7.2.4.6 Radio channel coding	19
7.2.4.7 Radio channel decoding.....	19

7.2.4.8	Channel coding control.....	19
7.2.4.9	Initial (random) access detection and handling.....	19
7.2.4.10	CN Distribution function for Non Access Stratum messages	19
8	Mobility Management	19
8.1	Dedicated Connection.....	20
8.2	Consequences for Mobility Handling	20
8.3	Radio Network Temporary Identity.....	20
8.3.1	Usage of RNTI.....	20
9	Synchronisation	21
9.1	SYNCHRONISATION MODEL	21
9.1.1	Time Alignment handling.....	21
9.1.2	[FDD — Frame synchronisation	21
9.1.3	Radio Interface Synchronisation	22
9.1.4	Ciphering handling.....	22
9.1.5	Time-of-day handling.....	22
9.2	Network Synchronisation.....	22
9.3	Radio interface synchronisation.....	22
9.4	[FDD — Frame Synchronisation]	24
9.4.1	General principles for frame synchronisation.....	24
9.4.2	UE Frame Number definition.....	25
9.4.3	CFN-CELL FN Offset.....	25
9.4.4	Use of frame numbers in uplink and downlink transmission.....	26
9.4.5	Timing adjustment in Iub/Iur interfaces	27
9.4.6	Initial synchronisation of the first dedicated branch.....	27
9.4.7	Initial synchronisation of a additional soft handover branches.....	27
9.4.8	Maintaining offset	27
9.4.9	Synchronisation of L1 configuration changes	28
9.5	Node Synchronisation.....	28
10	UTRAN OA&M Requirements	28
10.1	OA&M of Node B	28
10.1.1	Physical O&M.....	29
10.1.2	Logical O&M.....	29
11	UTRAN Interfaces.....	29
11.1	External Interfaces	29
11.1.1	Uu Interface.....	29
11.1.2	Iu Interface	29
11.1.2.1	Iu Overview	29
11.1.3	Streamlining functions.....	30
11.1.3.1	Access Network Triggered Streamlining.....	30
11.1.3.2	Core Network Triggered Streamlining	30
11.1.3.3	Iu Protocols	30
11.1.3.3.1	Radio Application Protocol.....	30
11.1.3.3.2	ALCAP Protocol.....	31
11.2	Internal Interfaces	31
11.2.1	Iur Interface.....	31
11.2.1.1	Iur Overview.....	31
11.2.1.2	Functional split over Iur	32
11.2.1.2.1	Macro-diversity Combining/Splitting	32
11.2.1.2.2	Control of Macro-diversity Combining/Splitting Topology.....	32
11.2.1.2.3	Handling of DRNS Hardware Resources.....	32
11.2.1.2.4	Allocation of Downlink Channelisation Codes	32
11.2.1.2.5	UpLink Power Control.....	32
11.2.1.2.6	Down-Link Power Control.....	32
11.2.1.2.7	Admission Control	32
11.2.1.3	DRNS logical Model over Iur	32
11.2.1.3.1	Overview.....	32
11.2.1.3.2	Logical Model Elements	33
11.2.1.3.2.1	Radio Link.....	33

11.2.1.3.2.2	Cell	33
11.2.1.3.2.3	Iur Data Stream	33
11.2.1.3.2.4	Iur User Port	33
11.2.1.3.2.5	Iur Control Port	34
11.2.1.4	Iur Protocols	34
11.2.2	Iub Interface	34
11.2.2.1	Iub Overview	34
11.2.2.2	Functional split over Iub	35
11.2.2.2.1	Traffic management	35
11.2.2.2.1.1	Management of dedicated resources	35
11.2.2.2.1.2	Management of common radio channels	35
11.2.2.2.1.3	Control of traffic flows	35
11.2.2.2.2	Macro-diversity Combining of Radio Frames	35
11.2.2.2.3	Control of Macro-diversity Combining/Splitting Topology	35
11.2.2.2.4	Soft Handover Decision	36
11.2.2.2.5	Handling of Node B Hardware Resources	36
11.2.2.2.6	Allocation of Downlink Channelisation Codes	36
11.2.2.2.7	UpLink Power Control	36
11.2.2.2.8	Down-Link Power Control	36
11.2.2.2.9	Admission Control	36
11.2.2.3	Node B logical Model over Iub	36
11.2.2.3.1	Elements of the logical model	37
11.2.2.3.1.1	Radio Network Logical resources	37
11.2.2.3.1.2	Transport network logical resources	37
11.2.2.3.1.3	Node B Communication Contexts for Dedicated Channels	37
11.2.2.3.1.4	Common Channels	38
11.2.2.4	Iub Protocols	38
11.3	Protocol Model (Informative)	38
11.3.1	RACH Transport Channel	38
11.3.2	FACH Transport Channel	39
11.3.3	DCH Transport Channel	39
12	UTRAN Transport bearers	39
12.1	Iu Transport bearers	39
12.1.1	Radio Application Control Plane Transport bearers	39
12.1.2	Transport Network Control Plane Transport bearers	40
12.1.3	User Plane Transport bearers	40
12.2	Iur Transport bearers	40
12.2.1	Radio Application Control Plane Transport bearers	40
12.2.1.1	Addressing of RNSs over the Iur Interface	40
12.2.2	Transport Network Control Plane Transport bearers	40
12.2.3	User Plane Transport bearers	41
12.3	Iub Transport bearers	41
12.3.1	Radio Application Control Plane Transport bearers	41
12.3.2	Transport Network Control Plane Transport bearers	41
12.3.3	User Plane Transport bearers	41
13	UTRAN Performance Requirements	41
13.1	Delay Requirements	41
13.1.1	UTRAN delay requirements	41
	History	41

Intellectual Property Rights

Foreword

This Technical Specification has been produced by the 3rd Generation Partnership Project, Technical Specification Group <TSG name>.

The contents of this TS may be subject to continuing work within the 3GPP and may change following formal TSG approval. Should the TSG modify the contents of this TS, it will be re-released with an identifying change of release date and an increase in version number as follows:

Version m.t.e

where:

- m indicates [major version number]
- x the second digit is incremented for all changes of substance, i.e. technical enhancements, corrections, updates, etc.
- y the third digit is incremented when editorial only changes have been incorporated into the specification.

Scope

This document describes the overall architecture of the UTRAN, including internal interfaces and assumptions on the radio and Iu interfaces.

References

This text block applies to ALL deliverables. The sub-division below applies optionally to TSs.

The following documents contain provisions which, through reference in this text, constitute provisions of the present document.

- References are either specific (identified by date of publication, edition number, version number, etc.) or non-specific.
- For a specific reference, subsequent revisions do not apply.
- For a non-specific reference, the latest version applies.
- A non-specific reference to an ETS shall also be taken to refer to later versions published as an EN with the same number.

[1] Merged UTRAN Architecture Description V0.0.2

Editor's Note : [1] is a temporary reference only to ease the definition of what should be in the different sections of this document.

Definitions, symbols and abbreviations

Definitions

Editor's Note : Cleaned version of section 5.1 from [1] with a reference to a more general vocabulary document

Cell A cell is defined by a cell identity broadcasted on one physical channel.

A Cell is either FDD or TDD mode.

Iu Interconnection point between the RNS and the Core Network. It is also considered as a reference point.

Iub Interface between the RNC and the Node B.

Iur A logical interface between two RNS. Whilst logically representing a point to point link between RNSs, the physical realisation may not be a point to point link.

Logical Model A Logical Model defines an abstract view of a network or network element by means of information objects representing network element, aggregations of network elements, the topological relationship between the elements, endpoints of

connections (termination points), and transport entities (such as connections) that transport information between two or more termination points.

The information objects defined in the Logical Model are used, among others, by connection management functions. In this way, a physical implementation independent management is achieved.

Node B A logical node responsible for radio transmission/reception in one or more cells to/from the UE. Terminates the Iub interface towards the RNC.

Radio Network Controller This equipment in the RNS is in charge of controlling the use and the integrity of the radio resources.

Controlling RNC A role an RNC can take with respect to a specific set of Node B's. There is only one Controlling RNC for any Node B. The Controlling RNC has the overall control of the logical resources of its node B's.

Radio Network Subsystem Either a full network or only the access part of a UMTS network offering the allocation and the release of specific radio resources to establish means of connection in between an UE and the UTRAN.

A Radio Network Subsystem is responsible for the resources and transmission/reception in a set of cells.

Serving RNS A role an RNS can take with respect to a specific connection between an UE and UTRAN. There is one Serving RNS for each UE that has a connection to UTRAN. The Serving RNS is in charge of the radio connection between a UE and the UTRAN. The Serving RNS terminates the Iu for this UE.

Drift RNS The role an RNS can take with respect to a specific connection between an UE and UTRAN. An RNS that supports the Serving RNS with radio resources when the connection between the UTRAN and the UE need to use cell(s) controlled by this RNS is referred to as Drift RNS

Radio Access Network Application Part Radio Network Signalling over the Iu.

Radio Network Subsystem Application Part Radio Network Signalling over the Iur.

RRC Connection A point-to-point bi-directional connection between RRC peer entities on the UE and the UTRAN sides, respectively. An UE has either zero or one RRC connection. See [6].

User Equipment A Mobile Equipment with one or several UMTS Subscriber Identity Module(s).

UMTS Terrestrial Radio Access Network UTRAN is a conceptual term identifying that part of the network which consists of RNCs and Node Bs between Iu and Uu. The concept of UTRAN instantiation is currently undefined.

Radio Link The set of (radio) physical channels comprised in a transmission path between a UE to one UTRAN access point. See [6].

Abbreviations

Editor's Note : Cleaned version of section 5.2 from [1]

<u>CN</u>	<u>Core Network</u>
<u>DRNS</u>	<u>Drift RNS</u>
<u>RANAP</u>	<u>Radio Access Network Application Part</u>
<u>RNC</u>	<u>Radio Network Controller</u>
<u>RNS</u>	<u>Radio Network Subsystem</u>
<u>RNSAP</u>	<u>Radio Network Subsystem Application Part</u>
<u>SRNS</u>	<u>Serving RNS</u>

<u>UE</u>	<u>User Equipment</u>
<u>UMTS</u>	<u>Universal Mobile Telecommunication System</u>
<u>USIM</u>	<u>UMTS Subscriber Identity Module</u>
<u>UTRAN</u>	<u>UMTS Terrestrial Radio Access Network</u>

Notation

Editor's Note : Section 5.4 from [1]

Parts of the document apply only to one mode, FDD or TDD. Any such area will be tagged by [FDD — xxxxxxxxx] and [TDD — yyyyyyyyyyy] respectively. The tag applies to the text until the closing bracket.

General principles

Editor's Note : This section will list the fundamental principles guiding the work on architecture definition. The content of section 7 of [1] will be put there. Section 12.5.2.1 of [1] "Iub General principles" should also be put in this section after revisiting it for more generality.

The general principles guiding the definition of UTRAN Architecture as well as the UTRAN interfaces are the following :

- Logical separation of signalling and data transport networks
- UTRAN and CN functions are fully separated from transports functions. Addressing scheme used in UTRAN and CN shall not be tied to the addressing schemes of Transport functions. The fact that some UTRAN or CN function resides in the same equipment as some transport functions does not make the transport functions part of the UTRAN or the CN.
- Macro diversity is fully handled in the UTRAN
- Mobility for RRC connection is fully controlled by the UTRAN.

Note : Handover to other Access Networks is FFS.

Editor's Note : the following part is an editorial proposal for section 12.5.2.1 of [1] revisited for more generality

When defining the UTRAN interfaces the following principles were followed :

- The functional division across the interfaces shall have as few options as possible.
- Interfaces should be based on a logical model of the entity controlled through this interface

Editor's Note : The following part is an editorial proposal extracted from section 13.1 of [1] and made more general.

Transport Network Control Plane is a functional plane in the interfaces protocol structure that is used for the transport bearer management. The actual signalling protocol that is in use within the Transport Network Control Plane depends on the underlying transport layer technology. The intention is not to specify a new UTRAN specific Application Part for the Transport Network Control Plane but to use signalling protocols standardised in other groups (if needed) for the applied transport layer technology.

UMTS General architecture

Overview

Editor's Note : This section will place the UTRAN within its context and interfaces. Content of section 6 of [1] will be put there.

Figure 1. shows a simplified UMTS architecture with the external reference points and interfaces to the UTRAN. The architecture is based on document [1].

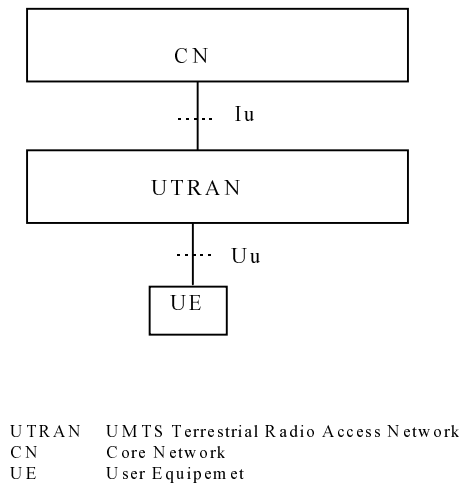

Figure 1. UMTS Architecture

General protocols architecture

Editor's Note : Sections 12.1(including subsections) is proposed to be placed under this section.

The protocols over Uu and Iu interfaces are divided into two structures:

- **User plane protocols**
 These are the protocols implementing the actual radio access bearer service, i.e. carrying user data through the access stratum.
- **Control plane protocols**
 These are the protocols for controlling the radio access bearers and the connection between the UE and the network from different aspects (including requesting the service, controlling different transmission resources, handover & streamlining etc.). Also a mechanism for transparent transfer of NAS messages is included.

6.1.1 User plane

The radio access bearer service is offered from SAP to SAP by the Access Stratum. The figure below shows the protocols on the Uu and Iu interfaces that linked together provide this radio access bearer service.

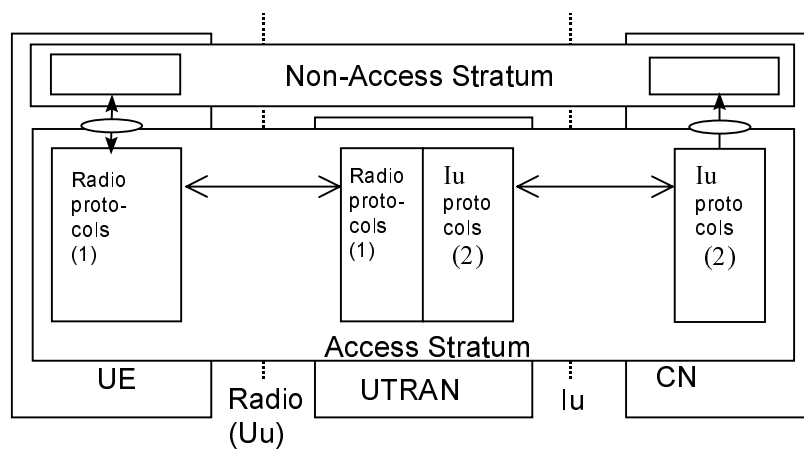

Figure 2. Iu and Uu User plane

(1) To be defined by TSG RAN WG2

(2) The protocols are defined in document S3.11 (description of Iu interface).

6.1.2 Control plane

The figure below shows the control plane (signalling) protocol stacks on Iu and Uu interfaces.

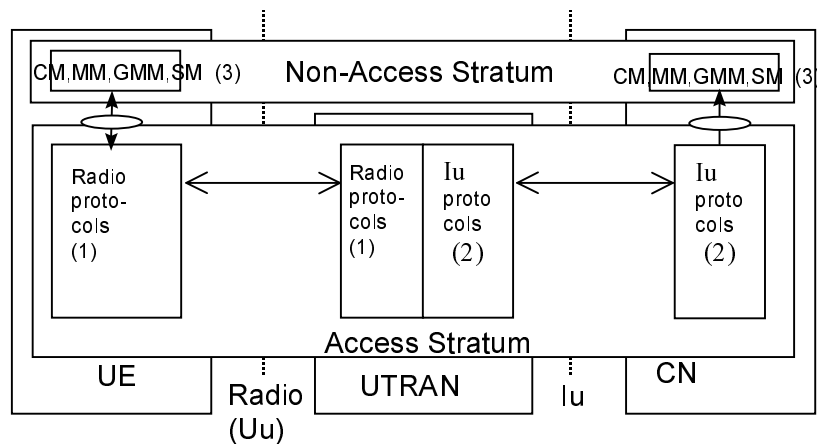

Figure 3. Iu and Uu Control plane

(1) To be defined by TSG RAN WG2 group

(2) The protocol is defined in document S3.11.(Description of Iu interface).(3) **CM,MM,GMM,SM**: This exemplifies a set of NAS control protocols between UE and CN. There may be different NAS protocol stacks in parallel. The evolution of the protocol architecture for these protocols is FFS.

Note : Both the Radio protocols and the Iu protocols contain a mechanism to transparently transfer NAS messages.

UTRAN Architecture

Editor's Note : Section 8 of [1]

The UTRAN consists of a set of Radio Network Subsystems connected to the Core Network through the Iu.

A RNS consists of a Radio Network Controller and one or more abstract entities currently called Node B. Node B are connected to the RNC through the Iub interface.

A Node B can support FDD mode, TDD mode or dual-mode operation.

The RNC is responsible for the Handover decisions that require signalling to the UE.

The RNC comprises a combining/splitting function to support macro diversity between different Node B.

The Node B can comprise an optional combining/splitting function to support macro diversity inside a Node B.

Inside the UTRAN, the RNCs of the Radio Network Subsystems can be interconnected together through the Iur. Iu(s) and Iur are logical interfaces. Iur can be conveyed over physical direct connection between RNCs or via any suitable transport network.

The UTRAN architecture is shown in Figure 4.

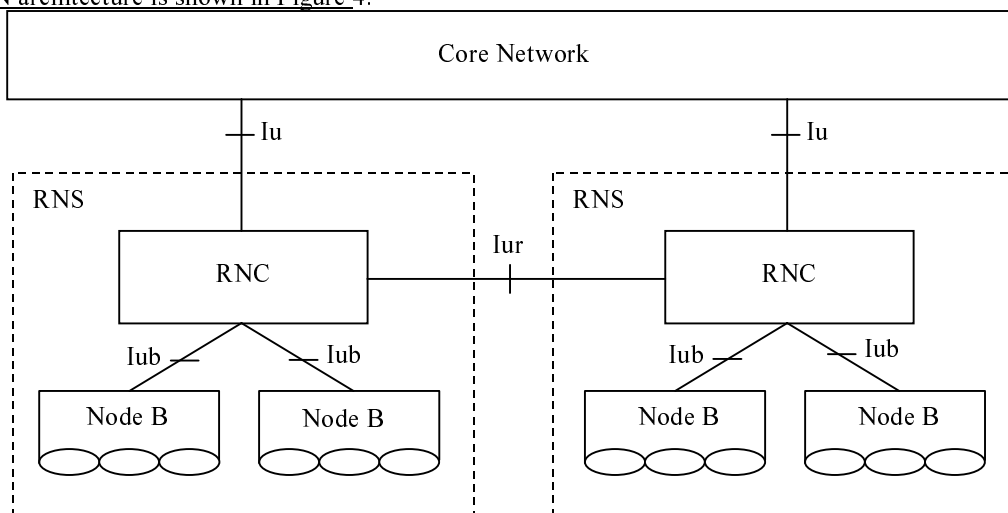

Figure 4. UTRAN Architecture

Each RNS is responsible for the resources of its set of cells.

For each connection between a User Equipment and the UTRAN, One RNS is the Serving RNS. When required, Drift RNSs support the Serving RNS by providing radio resources as shown in Figure 5. The role of an RNS (Serving or Drift) is on a per connection basis between a UE and the UTRAN.

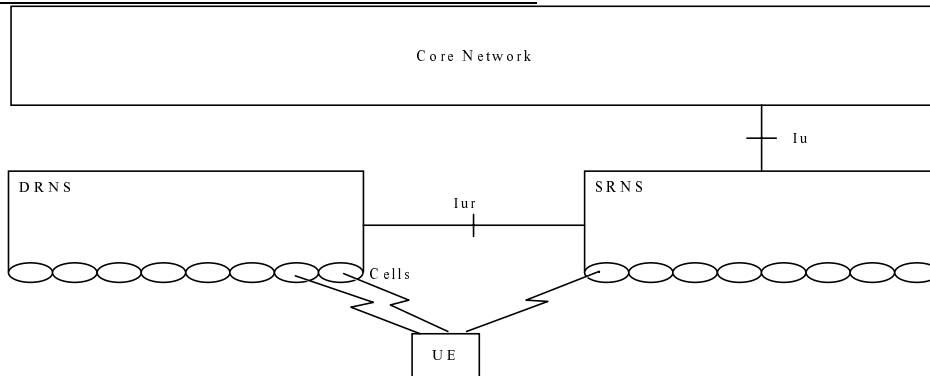

Figure 5. Serving and Drift RNS

UTRAN Functions description

Editor's Note : Section 11 and subsections of [1]

List of functions

Note : This list of functions, their classification and definitions is an initial list, classification and definitions that will be further refined.

- Functions related to overall system access control
 - Admission Control
 - Congestion Control
 - System information broadcasting
- Functions related to security and privacy
 - Use of Temporary Identifier
 - Radio channel ciphering
 - Radio channel deciphering
- Functions related to handover
 - Radio environment survey
 - Handover decision
 - Macro-diversity control
 - Handover Control
 - Handover execution
 - Handover completion
 - SRNS Relocation
 - Inter-System handover
- Functions related to radio resource management and control
 - Radio bearer connection set-up and release (Radio Bearer Control)

- Reservation and release of physical radio channels
- Allocation and deallocation of physical radio channels
- Packet data transfer over radio function
- RF power control
- RF power setting
- Radio channel coding
- Radio channel decoding
- Channel coding control
- Initial (random) access detection and handling
- CN Distribution function for Non Access Stratum messages

Functions description

6.1.3 Functions related to overall system access control

System access is the means by which a UMTS user is connected to the UMTS in order to use UMTS services and/or facilities. User system access may be initiated from either the mobile side, e.g. a mobile originated call, or the network side, e.g. a mobile terminated call.

6.1.3.1 Admission Control

The purpose of the admission control is to admit or deny new users, new radio access bearers or new radio links (for example due to handover). The admission control should try to avoid overload situations and base its decisions on interference and resource measurements. The admission control is employed at for example initial UE access, RAB assignment/reconfiguration and at handover. These cases may give different answers depending on priority and situation.

Note : This admission Control function is related to Radio Resources

6.1.3.2 Congestion Control

The task of congestion control is to monitor, detect and handle situations when the system is reaching a near overload or an overload situation with the already connected users. This means that some part of the network has run out, or will soon run out of resources. The congestion control should then bring the system back to a stable state as seamless as possible.

Note : This admission Control function is related to Radio Resources

6.1.3.3 System information broadcasting

This function provides the mobile station with the information which is needed to camp on a cell and to set up a connection in idle mode and to perform a handover or route packets in communication mode. The tasks may include :

- access rights
- frequency bands used
- configuration of logical channels, PCH, FACH and RACH channel structure of the cell etc.
- network and cell identities
- information for location registration purposes
- UE idle mode cell selection and cell re-selection criteria
- UE transmission power control information
- UE access and admission control information

Because of its close relation to the basic radio transmission and the radio channel structure, the basic control and synchronisation of this function should be located in UTRAN.

6.1.4 Functions related to security and privacy

6.1.4.1 Use of Temporary Identifier

UTRAN shall, as far as possible, use a temporary identifier instead of the permanent CN assigned identity (e.g. IMSI, International Mobile Subscriber Identity).

This function is located in the UE and in the UTRAN

6.1.4.2 Radio channel ciphering

This function is a pure computation function whereby the radio transmitted data can be protected against a non-authorised third-party. Ciphering may be based on the usage of a session-dependent key, derived through signalling and/or session dependent information.

This function is located in the UE and in the UTRAN.

6.1.4.3 Radio channel deciphering

This function is a pure computation function which is used to restore the original information from the ciphered information. The deciphering function is the complement function of the ciphering function, based on the same ciphering key.

This function is located in the UE and in the UTRAN.

6.1.5 Functions related to handover

6.1.5.1 Radio environment survey

This function performs measurements on radio channels (current and surrounding cells) and translates these measurements into radio channel quality estimates. Measurements may include :

1. received signal strengths (current and surrounding cells),
2. estimated bit error ratios, (current and surrounding cells),
3. estimation of propagation environments (e.g. high-speed, low-speed, satellite, etc.),
4. transmission range (e.g. through timing information),
5. Doppler shift,
6. synchronisation status,
7. Received interference level,
8. Total DL transmission power per cell.

In order for these measurements and the subsequent analysis to be meaningful, some association between the measurements and the channels to which they relate should be made in the analysis. Such association may include the use of identifiers for the network, the base station, the cell (base station sector) and/or the radio channel.

This function is located in the UE and in the UTRAN.

6.1.5.2 Handover decision

This function consists of gathering estimates of the quality of the radio channels (including estimates from surrounding cells) from the measuring entities and to assess the overall quality of service of the call. The overall quality of service is compared with requested limits and with estimates from surrounding cells. Depending on the outcome of this comparison, the *macro-diversity control function* or the *handover control function* may be activated.

This function may also include functionalities to assess traffic loading distribution among radio cells and to decide on handing over traffic between cells for traffic reasons.

The location of this function is depending on the handover principle chosen.

- if network only initiated handover, this function is located in the RNC;
- if mobile only initiated handover, this function is located in the UE;

- if both the mobile and the network can initiate handover, this function will be located in both the RNC and the UE.

6.1.5.3 Macro-diversity control

Upon request of the *Handover Decision function*, this function controls the duplication/ replication of information streams to receive/ transmit the same information through multiple physical channels (possibly in different cells) from/ towards a single mobile terminal.

This function also controls the combining of information streams generated by a single source (diversity link), but conveyed via several parallel physical channels (diversity sub-links). Macro diversity control should interact with channel coding control in order to reduce the bit error ratio when combining the different information streams. This function controls macro-diversity execution which is located at the two endpoints of the connection element on which macro-diversity is applied (diversity link), that is at the access point and also at the mobile termination.

In some cases, depending on physical network configuration, there may be several entities which combine the different information streams, e.g. one entity combines information streams on radio signal basis, another combines information streams on wireline signal basis.

This function is typically located in the UTRAN. However, depending on the physical network architecture, some bit stream combining function within the CN may have to be included in the control.

6.1.5.4 Handover Control

In the case of switched handover, this function is responsible for the overall control of the handover execution process. It initiates the handover execution process in the entities required and receives indications regarding the results.

Due to the close relationship with the radio access and the Handover Decision function, this function should be located in the UTRAN.

6.1.5.5 Handover execution

This function is in control of the actual handing over of the communication path. It comprises two sub-processes: *handover resource reservation* and *handover path switching*. The *handover resource reservation* process will reserve and activate the new radio and wireline resources that are required for the handover. When the new resources are successfully reserved and activated, the *handover path switching* process will perform the final switching from the old to the new resources, including any intermediate path combination required, e.g. radio link addition and radio link deletion in the soft handover case.

This function is located in the UTRAN for UTRAN internal path switching and in the CN for CN path switching.

6.1.5.6 Handover completion

This function will free up any resources that are no longer needed. A re-routing of the call may also be triggered in order to optimise the new connection.

This function is located both in the UTRAN and in the CN.

6.1.5.7 SRNS Relocation

The SRNS Relocation function coordinates the activities when the SRNS role is to be taken over by another RNS. SRNS relocation implies that the Iu interface connection point is moved to the new RNS.

This function is located in the RNC and the CN.

6.1.5.8 Inter-System handover

The Inter-system handover function enables handover to and from e.g. GSM BSS, PDC system.

This function is located in the UTRAN, the UE and the CN.

6.1.5.8.1 Handover from UMTS to GSM

In case of inter-system environment, UTRAN transmits a list of GSM neighbour cells to the mobile. Based on measurements made by the dual mode UE, the RNC can decide to perform a handover to GSM cells.

After this decision, RNC sends one target cell in Hard Handover Required message to the MSC. Since, the MSC knows the complete configuration on a cell basis of each BSC connected to him, he can transfer as in GSM the Request to handover to the target BSC. The BSC activates a new channel on the target cell and prepare Handover Command message which will be transferred to the UE transparently through the RNC. After the successful execution of the handover, resources on source RNC are released.

- Handover from UMTS to GSM may need service re-negotiation: this point is FFS

6.1.5.8.2 Handover from GSM to UMTS

Handover from GSM to UMTS may occur for two reasons:

- radio coverage reason
- service reason : this point is FFS

In case of inter-system environment, BSC broadcasts a list of UMTS neighbour cells in System Information message. A dual mode UE arriving in boarder of GSM coverage will perform measurements on UMTS cells. Based on these measurements, the BSC can decide to perform a handover to UMTS cells

Then, the BSC¹ sends a Handover Required message with a cell list to the MSC. The MSC is not able to determine the location of the requested UMTS cells only with cell identity. At least, source BSC shall identify a UMTS cell with RNC and cell identifiers, so that the MSC knows to which RNC, he have to send Hard Handover Request message. On receipt of this message, the RNC activates a channel on the requested cell and prepares Handover Command which is sent transparently to the UE through the BSC. After the successful execution of the handover, resources on source BSC are released.

6.1.6 Functions related to radio resource management and control

Radio resource management is concerned with the allocation and maintenance of radio communication resources. UMTS radio resources must be shared between circuit transfer mode services and packet transfer modes services (i.e. Connection-oriented and/or connectionless-oriented services).

6.1.6.1 Radio bearer connection set-up and release (Radio Bearer Control)

This function is responsible for the control of connection element set-up and release in the radio access sub network.

The purpose of this function is

1. to participate in the processing of the end-to-end connection set-up and release.
2. and to manage and maintain the element of the end-to-end connection, which is located in the radio access sub network.

In the former case, this function will be activated by request from other functional entities at call set-up/release. In the latter case, i.e. when the end-to-end connection has already been established, this function may also be invoked to cater for in-call service modification or at handover execution. This function interacts with the *reservation and release of physical (radio) channels* function.

This function is located both in the UE and in the RNC.

6.1.6.2 Reservation and release of physical radio channels

This function consists of translating the connection element set-up or release requests into physical radio channel requests, reserving or releasing the corresponding physical radio channels and acknowledging this reservation/ release to the requesting entity.

This function may also perform physical channel reservation and release in the case of a handover. Moreover, the amount of radio resource required may change during a call, due to service requests from the user or macro-diversity requests. Therefore, this function must also be capable of dynamically assigning physical channels during a call.

Note: This function may or may not be identical to the function allocation and deallocation of physical radio channels. The distinction between the two functions is required e.g. to take into account sharing a physical radio channel by multiple users in a packet data transfer mode.

This function is located in the UTRAN.

6.1.6.3 Allocation and deallocation of physical radio channels

This function is responsible, once physical radio channels have been reserved, for actual physical radio channel usage, allocating or deallocating the corresponding physical radio channels for data transfer. Acknowledging this allocation/ deallocation to the requesting entity is for further study.

Note: This function may or may not be identical to the function reservation and release of physical radio channels. The distinction between the two functions is required e.g. to take into account sharing a physical radio channel by multiple users in a packet data transfer mode.

This function is located in the UTRAN.

¹ The behaviour of the BSC is given as an example since it is out of the scope of ARC EG

6.1.6.4 Packet data transfer over radio function

This function provides packet data transfer capability across the UMTS radio interface. This function includes procedures which:

1. provide packet access control over radio channels.
2. provide packet multiplexing over common physical radio channels.
3. provide packet discrimination within the mobile terminal.
4. provide error detection and correction.
5. provide flow control procedures.

This function is located in both the UE and in the UTRAN.

It encompasses :

1. Channel type switching : UTRAN shall have the possibility to dynamically, during an RRC connection, switch between a Common Transport and a Dedicated Transport Channel. This to optimise the radio resource utilisation and to achieve the QoS requested by the packet data user.
2. Channel rate modification : UTRAN shall have the possibility to dynamically, during an RRC connection, modify the channel rate of a Dedicated Transport Channel. This to optimise the radio resource utilisation and to achieve the QoS requested by the packet data user.
3. Packet scheduling : When performing data transfer, it shall be possible to schedule data transmissions according to QoS.
4. Retransmission : For assured mode radio access bearers, UTRAN shall support retransmission of unacknowledged data over the radio interface. This, in order to assure a certain packet loss probability.
5. Packet discard : If, for example, the communication over the radio interface fails and parts of an Access Stratum SDU (e.g. an IP packet) are lost, or due to congestion within UTRAN a part of an Access Stratum SDU is dropped, UTRAN shall discard the whole Access Stratum SDU. This is to ensure that radio resources are not unnecessarily wasted. It is expected that higher layers (transport protocols) will perform the necessary retransmissions.
6. Avoidance of IP fragmentation: UTRAN shall be able to handle Access Stratum SDUs up to a size which is large enough to avoid IP fragmentation in most cases.

6.1.6.5 RF power control

This group of functions controls the level of the transmitted power in order to minimise interference and keep the quality of the connections. It consist of the following functions: UL Outer Loop Power Control, DL Outer Loop Power Control, UL Inner Loop Power Control, DL Inner Loop Power Control, UL Open Loop Power Control and DL Open Loop Power Control.

6.1.6.5.1 UL OUTER LOOP POWER CONTROL

The UL Outer Loop Power Control sets the target quality value for the UL Inner Loop Power Control. It receives input from quality estimates of the transport channel. The UL outer loop power control is mainly used for a long-term quality control of the radio channel.

This function is located in the UTRAN.

6.1.6.5.2 DL OUTER LOOP POWER CONTROL

The DL Outer Loop Power Control sets the target quality value for the DL inner loop power control. It receives input from quality estimates of the transport channel, measured in the UE. The DL outer loop power control is mainly used for a long-term quality control of the radio channel.

This function is located mainly in the UE, but some control parameters are set by the UTRAN.

6.1.6.5.3 UL INNER LOOP POWER CONTROL

The UL Inner Loop Power Control sets the power of the uplink dedicated physical channels. It receives the quality target from UL Outer Loop Power Control and quality estimates of the uplink dedicated physical control channel. The power control commands are sent on the downlink dedicated physical control channel to the UE.

This function is located in both the UTRAN and the UE.

6.1.6.5.4 DL INNER LOOP POWER CONTROL

The DL Inner Loop Power Control sets the power of the downlink dedicated physical channels. It receives the quality

target from DL Outer Loop Power Control and quality estimates of the downlink dedicated physical control channel. The power control commands are sent on the uplink dedicated physical control channel to the UTRAN. This function is located in both the UTRAN and the UE.

6.1.6.5.5 UL OPEN LOOP POWER CONTROL

The UL Open Loop Power Control sets the initial power of the UE, i.e. at random access. The function uses UE measurements and broadcasted cell/system parameters as input. This function is located in both the UTRAN and the UE.

6.1.6.5.6 DL OPEN LOOP POWER CONTROL

The DL Open Loop Power Control sets the initial power of downlink channels. It receives downlink measurement reports from the UE. This function is located in both the UTRAN and the UE.

6.1.6.6 Radio channel coding

This function introduces redundancy into the source data flow, increasing its rate by adding information calculated from the source data, in order to allow the detection or correction of signal errors introduced by the transmission medium. The channel coding algorithm(s) used and the amount of redundancy introduced may be different for the different types of logical channels and different types of data. This function is located in both the UE and in the UTRAN.

6.1.6.7 Radio channel decoding

This function tries to reconstruct the source information using the redundancy added by the channel coding function to detect or correct possible errors in the received data flow. The channel decoding function may also employ a priori error likelihood information generated by the demodulation function to increase the efficiency of the decoding operation. The channel decoding function is the complement function to the channel coding function. This function is located in both the UE and in the UTRAN.

6.1.6.8 Channel coding control

This function generates control information required by the channel coding/ decoding execution functions. This may include channel coding scheme, code rate, etc. This function is located in both the UE and in the UTRAN.

6.1.6.9 Initial (random) access detection and handling

This function will have the ability to detect an initial access attempt from a mobile station and will respond appropriately. The handling of the initial access may include procedures for a possible resolution of colliding attempts, etc. The successful result will be the request for allocation of appropriate resources for the requesting mobile station. This function is located in the UTRAN.

6.1.6.10 CN Distribution function for Non Access Stratum messages

In the RRC protocol, messages from the NAS shall be transparently transferred within the Access Stratum using the Direct Transfer procedure. In the two CN scenario, a distribution function in the UE and the SRNC shall handle a CN discriminator to direct messages to the appropriate NAS entity i.e. the appropriate Mobility Management instance in the UE domain and the appropriate CN domain.

In the downlink direction, the signaling bearers addressing shall be used to identify the originating CN domain (e.g. from CN node originating address). The process performed by the distribution function simply consists in adding one CN discriminator to the value corresponding to the originating CN domain and passing the NAS message to the underneath protocol layers for transparent transfer to the UE.

In the uplink direction, the process performed by the distribution function in the SRNC consists in removing the CN discriminator inserted by the peer UE function and distribute the NAS message to the corresponding RANAP instance for transfer over Iu interface.

This function is located in both the UE and in the SRNC.

Mobility Management

Editor's Note : Section 9 and subsections of [1]

Note : Location based services have not been yet considered and need further studies.

Dedicated Connection

Based on [2], the UE may either have or not have a dedicated connection :

1. There exists a dedicated connection established over the Dedicated Control Service Access Point (DC-SAP) from the Access Stratum.

In this case, the CN can reach the UE by the dedicated connection SAP on the CN side, and the UTRAN has a context with the UE and CN for this particular connection. This context is erased when the connection is released. The *dedicated connection* can be initiated from the UE only.

Editor's note : A dedicated connection is currently defined as Signalling Connection in [2]. Note that in the radio interface, dedicated or common channels can be used.

Depending on the activity of a UE, the location of the UE is known either on cell level (higher activity) or in a larger area consisting of several cells (lower activity). This will (i) minimise the number of location update messages for moving UEs with low activity and (ii) remove the need for paging for UEs known on cell level.

2. There does not exist a dedicated connection.

In this case, the CN must reach the UE via the Notification SAP. The message sent to the UE can be a request to the UE to establish a dedicated connection. The UE is addressed with a user/terminal identity and a 'geographical area'.

Consequences for Mobility Handling

It is generally agreed [1] to contain radio access specific procedures within UTRAN. This means that all cell level mobility should be handled within UTRAN. Also the cell structure of the radio network should not necessarily be known outside the UTRAN.

When there exists a dedicated connection to the UE, the UTRAN shall handle the radio interface mobility of the UE. This includes procedures such as soft handover, and procedures for handling mobility in the RACH/PCH substate.

Editor's note : Some reference will be necessary to a 3GPP TSG RAN WG2 document that defines that substate.

When there does not exist a dedicated connection to the UE, no UE information in UTRAN is needed. In this case, the mobility is handled directly between UE and CN outside access stratum (e.g. by means of registration procedures).

When paging the UE, the CN indicates a 'geographical area' that is translated within UTRAN to the actual cells that shall be paged. A 'geographical area' shall be identified in a cell-structure independent way. One possibility is the use of 'Location Area identities'.

During the lifetime of the dedicated connection, the registrations to the CN are suppressed by the UE. When a dedicated connection is released, the UE performs a new registration to the CN, if needed.

Thus, the UTRAN does not contain any permanent 'location registers' for the UE, but only temporary contexts for the duration of the dedicated connection. This context may typically contain location information (e.g. current cell(s) of the UE) and information about allocated radio resources and related connection references.

Radio Network Temporary Identity

Note : This RNTI definition and usage needs to be confirmed by 3GPP TSG RAN WG2.

Radio Network Temporary Identities (RNTI) are used as UE identifiers within UTRAN and in signalling messages between UE and UTRAN.

Two types of RNTI exist. One is used within the Serving RNC and it is denoted by Serving RNC RNTI (s-RNTI), the other is used within C-RNC, when applicable, and it is denoted by Controlling RNC RNTI (c-RNTI).

s-RNTI is allocated for all UEs having a RRC connection, it is allocated by the Serving RNC and it is unique within the Serving RNC. s-RNTI is reallocated always when the Serving RNC for the RRC connection is changed.

In addition, each RNC has a unique identifier within the PLMN, denoted by RNC identifier (RNC-ID).

c-RNTI for an UE is allocated by each controlling RNC through which UE is able to communicate on DCCH. c-RNTI is unique within the allocating C-RNC. c-RNTI is always allocated when a new UE context is created to a RNC. UE is aware of its c-RNTI only when in RACH/FACH state, while c-RNTI is used as a UE identifier within UTRAN in all UE states. Serving RNC is always aware of all c-RNTIs allocated for the UE.

6.1.7 Usage of RNTI

S-RNTI together with the RNC-ID is used as a UE identifier in all CCCH and (in UTRAN originated) PCCH messages on the air interface. RNC-ID is used by Controlling RNC to route the received uplink messages towards the Serving RNC.

C-RNTI is used as a UE identifier in all DCCH/DTCH common channel messages on air interface. c-RNTI is also used

as a UE identifier in the connectionless RNSAP protocol messages on the Iur interface.

Synchronisation

Editor's Note : Section 10 and subsections of [1]

This section describes a number of synchronisation principles grouped into three groups: Network Synchronisation, Frame Synchronisation and Node Synchronisation.

SYNCHRONISATION MODEL

The Synchronisation model includes nodes and interactions in UTRAN as well as points at interactions to Core Network (CN) and User Equipment (UE).

The objectives with the sync model are to describe where the interactions mainly take place and to define the following terms:

- Time Alignment handling
- Frame synchronisation
- Radio Interface Synchronisation handling
- Ciphering handling

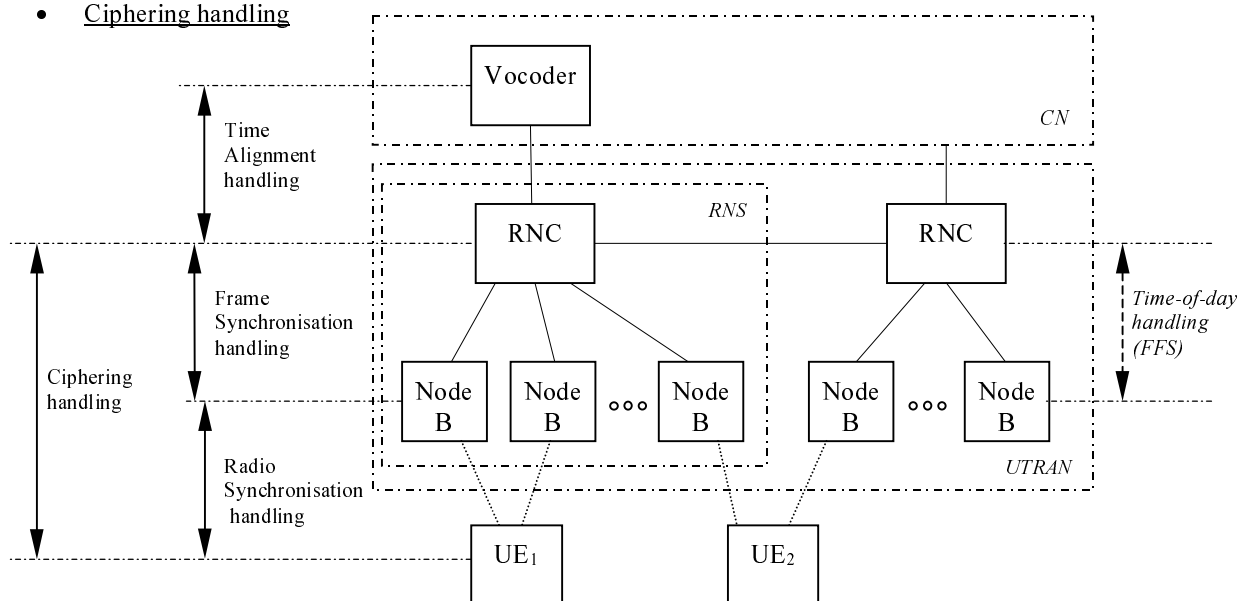

Figure 6. Synchronisation issues model.

The *Time-of-day* is an option FFS, used for OAM functions like radio network event time-stamping. Network synchronisation is a prerequisite for UTRAN and CN nodes.

6.1.8 Time Alignment handling

Time Alignment handling is the functionality to adapt to 10 ms framing (or to unit length e.g. 20 ms) i.e. to send and receive frames 'just-in-time' and thus minimizing the delay. TA is an issue between Vocoders and the Diversity handover unit (DHO) in RNC. TA could also be used for circuit switched services like data.

6.1.9 [FDD — Frame synchronisation

Frame synchronisation is the functionality to secure that the same DL frames are sent in the involved Node Bs towards UE and that the same UL frames are combined in RNC (in the Diversity Handover unit, DHO).

This is done by managing Frame Offset values that could be set differently in DL and UL.

Frames are sent from RNC to Node Bs the DL Frame Offset value earlier compared with when they are to be sent in Node Bs towards UE.

Frames are combined in RNC the UL Frame Offset value later compared to when they are received by Node B.

Frame Offset values could be predefined in the system but could also be refined during operation. Frame Offset values are handled in RNC only. Refining the DL Frame Offset values requires Iub signalling from Node Bs to RNC and contains the Frames discard rate and the Frames received too early rate in Node Bs. Refining the UL Frame Offset values requires no Iub signalling (RNC internal only).

The delay requirement for Voice is hard to fulfil. Therefore, Voice is transferred over the transport network using a Quality of Service (QoS) that has short buffers compared with e.g. packet data. This means that the Voice Frame Offset

values could be shorter than those for packet data in order to have a chance to fulfil the Voice delay requirements. *Note : Due to TFI coordination in MAC layer, some situations could exist where the same frame offset would be required for different services. This will require further studies.]*

6.1.10 Radio Interface Synchronisation

Radio Interface Synchronisation is an issue mainly between UE and Node Bs. Radio Interface Synchronisation is used at addition of a new radio link (Soft-Handover, SHO) or when changing to another radio link (Hard-Handover, HHO). Radio Interface Synchronisation includes use cases like Establishment of first radio link, Inter-/Intra-RNS SHO and Inter-/Intra-frequency Hard-Handover which could be seamless or non-seamless.

6.1.11 Ciphering handling

Services transferred over the air-interface need ciphering for security reasons. The length of the ciphering counter is in the range of 2^{32} . The UE specific ciphering counter must be synchronised between UE and RNC.

6.1.12 Time-of-day handling

Time-of-day handling is optional and is FFS.

Network Synchronisation

The Network Synchronisation relates to the stability of the clocks in the UTRAN. The standard will specify the performance requirements on the radio interface. Also the characteristics on the UTRAN internal interfaces, in particular lub, need to be specified.

Editor's note : The short-term stability (e.g. over a symbol or frame) of the Node B transmitter is an issue for the LI EG. However, the long-term stability is related to the Node Synchronisation (see below), and may need to be specified taking the Node Synchronisation into account.

Radio interface synchronisation

This section firstly defines some physical channel timing parameters that are necessary for the radio interface synchronisation. See [7] for more details. Then the radio interface synchronisation procedure is described.

The following assumptions are considered:

- a Node B covers N cells, where $N \geq 1$;
- each Node B has a Reference Frame Number (RFN) which counts from 0 to $M-1$ in Radio Frame intervals;
- each cell has a Frame Number (FN) which counts from 0 to $M-1$ in Radio Frame intervals;
- the cell FN is broadcasted on the BCCH;
- cells are asynchronous among each others (Primary CCPCH are not synchronised).

Note : No assumptions have been made on the values of the Frame Number. The following alternatives are possible:

- each cell has an independent FN;
- FN is unique inside each Node B;
- FN is unique inside each RNS;
- FN is unique in a PLMN.

The physical channel timing parameters in a soft handover situation including two cells belonging to two different Nodes B (Cell i belonging to Node B1 and Cell j belonging Node B2) are described below and shown in Figure 7.

- T_p : Propagation delay between cell and UE.
- T_{cell} : This timing offset is used for the frame timing of SCH, Primary CCPCH and the starting phase of all down link Scrambling Codes in a cell. The main purpose is to avoid having overlapping SCHs in different cells belonging to the same Node B.
- T_d : This timing offset is used for the frame timing of DPCHs and Secondary CCPCHs. It can be individually set up for each DPCH and Secondary CCPCH. The T_d values for the latter may be broadcast on BCCH, or known a-priori. The purpose of T_d is:

- In an originating/terminating cell, to distribute discontinuous transmission periods in time, and also to distribute Node B-RNC transmission traffic in time.
- At soft handover, to synchronise down link DPCCHs to the same UE, in order to minimise the buffering requirements at the UE.

Note that T_d can only be adjusted in steps of one DPDCH/DPCCH symbol (256 chips) in order to preserve downlink orthogonality.

- T_m : This value is measured by the UE and reported to the RNC prior to soft handover. The RNC can then notify this value to the target cell, which then knows how to set T_d to achieve proper reception and transmission frame timing of the dedicated physical channel.



Figure 7. Physical channel timing parameters

The UE in active mode continuously searches for new cells on the current carrier frequency. From the cell-search procedure, the UE knows the frame offset (T_m) between the Primary CCPCH frame-timing received from the target cell and the earliest received existing DPCH path (see Figure 7.).
When a soft handover is to take place, this offset (T_m) together with the frame offset between the DPDCH/DPCCH and the Primary CCPCH of the source cell ($T_{d,i}$), is used to calculate the required frame offset ($T_{d,j}$) between the DPDCH/DPCCH and the Primary CCPCH of the destination cell, i.e. the cell to be added to the active set (see Figure 8.).

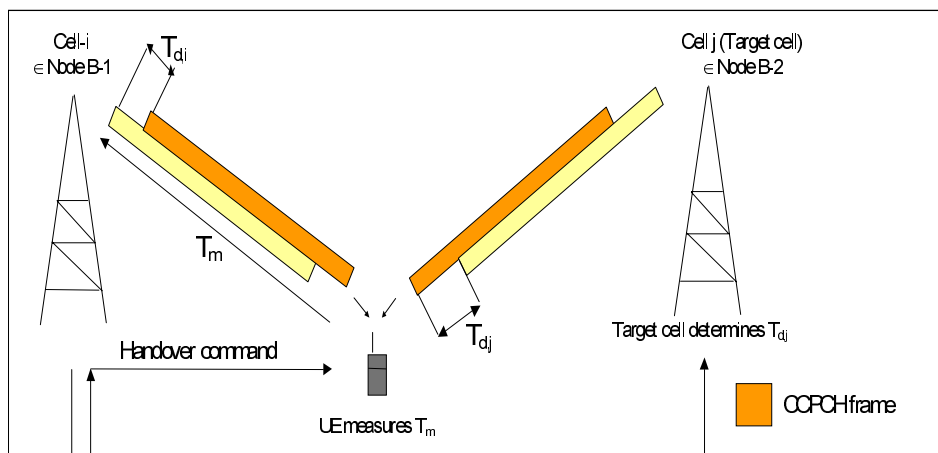

Figure 8. Radio interface downlink synchronisation (1)

This offset is chosen so that the frame offset between the DPDCH/DPCCH of the source and destination cells at the UE receiver is minimised.

Note that the propagation delay to the target cell is already compensated for in the setting of T_{di} at the target cell. The DPCH signal from the target cell will reach the UE at the same time as the earliest received existing DPCH path. The only remaining error, besides frequency-drift and UE mobility related errors, is due to a (known) rounding error at the target cell in order to maintain down link orthogonality.

The overall radio interface downlink synchronisation mechanism is shown in Figure 9.

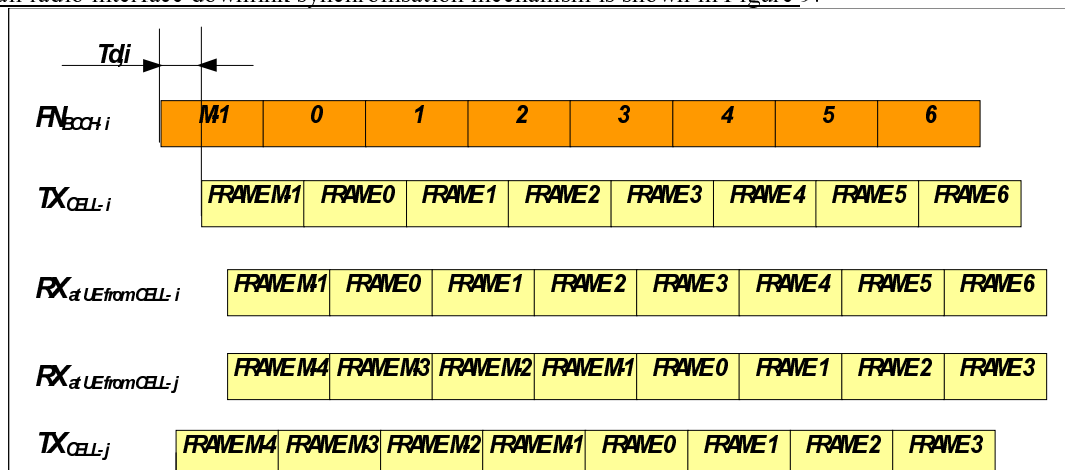

Figure 9. Radio interface downlink synchronisation (2)

[FDD — Frame Synchronisation]

Note : This whole section is applicable to FDD mode only.

The methods for Frame Synchronisation describe how data units transmitted in radio frames over different macrodiversity branches can be combined in the receiver, while minimising the delay for the radio access bearer service.

Editor's note: The L1 EG has described how the radio frame transmission timing in two different cells can be set in order for the UE to receive the frames synchronously. What remains is to make sure the same data is transmitted in a given radio frame (avoiding combining of radio frames with different data contents in the UE) and how the same two data units are combined in the RNC. Questions to consider include:

Different (possibly unknown) delays on the AAL2 connections over Iur / Iub to different Node B's

Numbering of data units over Iur/Iub to relate them to certain radio frames

How to achieve initial numbering for an RRC connection and in a Node B at Radio Link / Branch Addition

Varying delay: buffer with margins or adapt to adjust delay?

Relation to a time alignment protocol over Iu for minimising the roundtrip delay for e.g. a speech service.

Furthermore, the specifications may need to consider a delay budget from reception at RNC to transmission from Node B, and include some requirements on the different nodes processing delay.

6.1.13 General principles for frame synchronisation

The general principles for Frame Synchronisation are the following :

- each RNC has a Frame Number which count from 0 to $M-1$ in Radio Frame.
- The RNC Frame Number is used to determine the stamp for downlink DCH Data Stream Frames transmitted either on the Iub or on the Iur.
- In order to ensure that DCH Data Stream Frames containing the same data are received by all the involved cells in time to be transmitted synchronously to the UE, the SRNC anticipates the transmission on each macrodiversity branch. This timing advance should be about the maximum downlink transfer delay (Downlink

Offset).

- DCH Data Stream Frames that are not received in time to be transmitted synchronously to the UE are discarded.
- The cell FN is used to determine the stamp for uplink DCH Data Stream Frames transmitted on the Iub and Iur (in some proposals the Cell Frame Number is used to stamp uplink DCH Data Stream Frames).
- The RNC where selection/recombining takes place uses frame stamps of uplink DCH Data Stream Frames in order to combine correct frames.

These principles are shown in Figure 10.

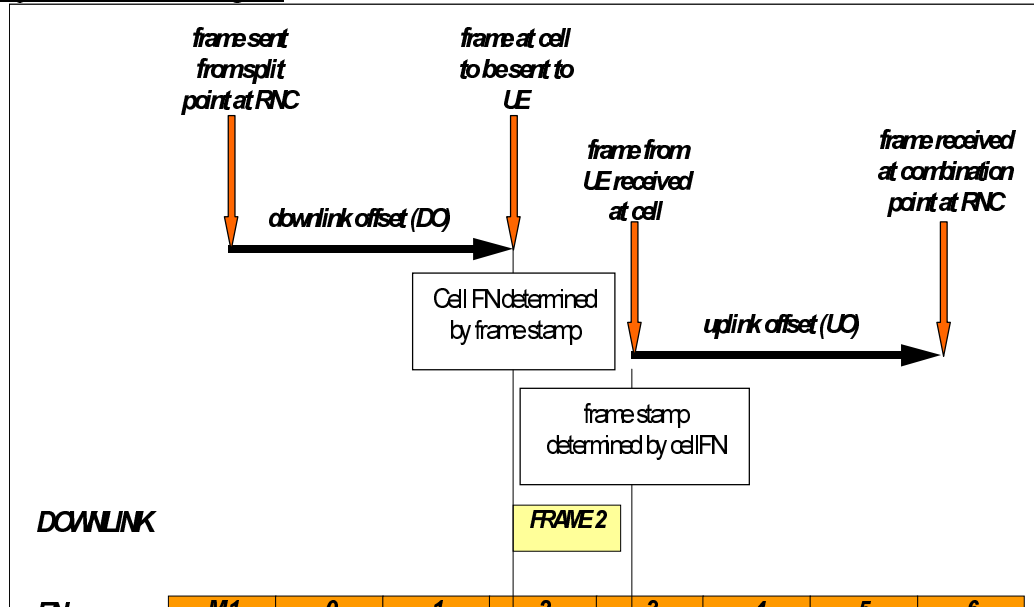

Figure 10. Frame stamping and uplink/downlink offsets handling

6.1.14 UE Frame Number definition

A cell in WCDMA system has its own specific frame numbering (FN_{CELL}), broadcast in the BCCH. FN_{CELL} of different Cells are not synchronised. The range of this frame number is 0-71, and one cycle lasts 720 ms (this is the current assumption in the SMG2-UMTS L1 EG)

The UE (acting as a master) sets its own reference for frame numbering ($UEFN$, UE Frame Number), composed by at least a Connection Frame Number (CFN) of the same range of the FN_{CELL} (0..71).

Note: The cycle of the CFN is selected to be equal to the cycle of the FN_{CELL} , and will change if the latter changes. Furthermore, the CFN is synchronous with the received DPDCH/DPCCH.

6.1.15 CFN-CELL FN Offset

Let's consider the case of a UE connected to Cell i belonging to Node B1, that is entering in soft handover with Cell j belonging Node B2.

From the cell-search procedure, the UE knows the frame offset (T_m) between the Primary CCPCH frame-timing received from the target cell and the earliest received existing DPCH path.

Furthermore, the UE measures the difference between its own CFN and the FN_{CELL} broadcast by the target cell:

$$OFF_j = CFN_{UE} - FN_{CELL-j}$$

When a soft handover is to take place, T_m is used to calculate the required offset (T_{d_j}) between the DPDCH/DPCCH and the Primary CCPCH of the destination cell, i.e. the cell to be added to the active set. This offset is chosen so that the frame offset between the DPDCH/DPCCH of the source and destination cells at the UE receiver is minimised.

Both T_m and OFF_j are included sent by the UE to UTRAN before the soft handover. The use of offset OFF_j is explained in Section 6.1.16 Use of frame numbers in uplink and downlink transmission.

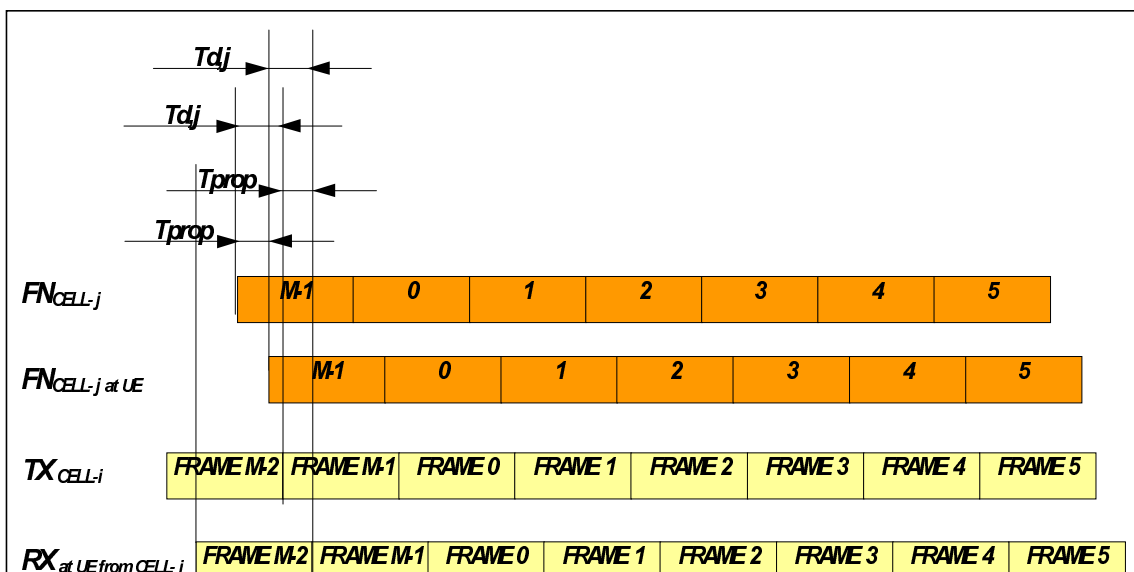

Figure 11. Offsets among Frame Counters

Note : If the network already knows the relation between the different FNCELL, then the UE does not need to report the OFF.

6.1.16 Use of frame numbers in uplink and downlink transmission

In UL transmission, each Node-B receiving the TBS calculates the corresponding CFN based on known FN_{CELL} and OFF , and includes it in the header of the Iub/Iur data frame carrying the TBS.

$$CFN = FN_{CELL-j} + OFF_j \text{ (modulo 72)}$$

The MDC unit in SRNC (and optionally in DRNC) combines uplink TBS with the same CFN.

If the $UEFN$ is used for encryption, UE ciphers the UL transport block sets (TBS) accordingly to the $UEFN$ of the first frames used for their transmission. SRNC deciphers them with the same $UEFN$.

In downlink transmission, SRNC numbers the DL TBS with the connection specific CFN in the Iur/Iub data frame header.

In order to ensure that TBS containing the same data are received by all the involved cells in time to be transmitted synchronously to the UE, the SRNC anticipates the transmission on each macrodiversity branch. This timing advance should be about the maximum downlink transfer delay (Downlink Offset). The exact time when SRNC shall transmit the DL Iub/Iur frame in the queue for transmission with the TBS and a specific CFN is defined by a DL Offset handling procedure (see Section 6.1.17 Timing adjustment in Iub/Iur interfaces Timing adjustment in Iub/Iur interfaces). Every cell transmits the TBS starting from:

$$FN_{CELL-j} = CFN - OFF_j$$

$T_{d,j}$ is used to set the required frame offset between the DPDCH/DPCCH and the Primary CCPCH of cell j , so that the transmission on the air-interface is synchronised.

If the $UEFN$ is used for encryption, SRNC ciphers the DL TBS accordingly to the $UEFN$ (of the first frames to be used for their transmission).

Note that, due to the transmission and processing delay, SRNC receives the UL TBS with $CFN = X$ after that the DL TBS with $CFN = X$ has been sent.

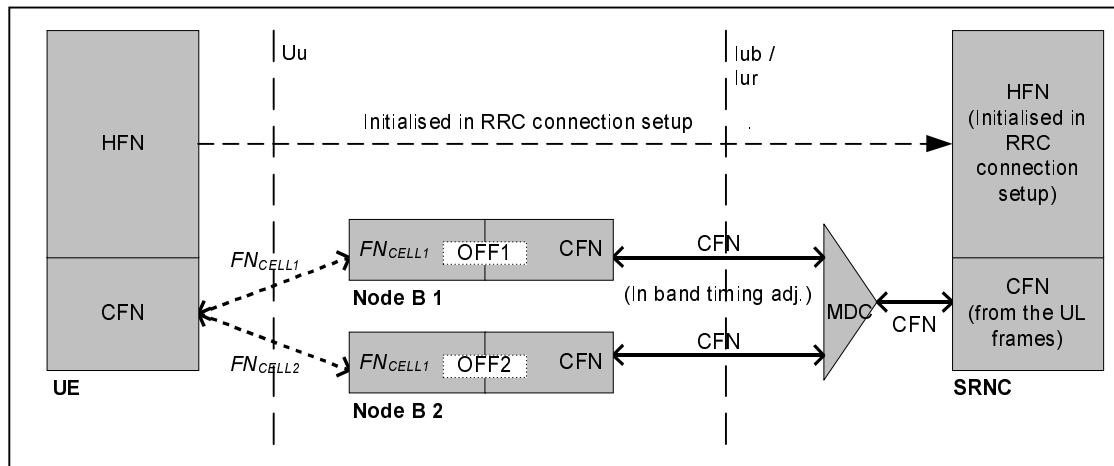

Figure 12. UE-UTRAN synchronisation

6.1.17 Timing adjustment in lub/lur interfaces

Downlink Offset values are found 'on-the-fly' according to current traffic situation either at connection set-up or when a diversity leg is needed. A certain margin can be added in both the UL and DL offsets to cope with a possible increase of transmission delay (ex: new link added).

The Link Offset values could be adjusted during the connection based on *Frame discard rate and Too early frame arrival rate* (at Node B and at SRNC respectively), in order to adapt to the current traffic situation.

Note : In case of speech connection with vocoder in CN, a frequent time adjustment shall be prevented in order to avoid frame-slips. This is done setting a margin in the uplink/downlink link offset as shown in the next subchapter.

Note : It is FFS if additional functionality should be introduced to improve the initial setting of DL offset values. (e.g. some background protocols)

6.1.18 Initial synchronisation of the first dedicated branch

The CFN and FN_{CELL} of the cell into which the RRC connection setup request was sent are synchronised (the CFN is set in UE to the same cycle as the FN_{CELL}). SRNC estimates the timing to send the first DL control frame, with a given CFN , in the new user plane. The correct DL transmission time is estimated by the SRNC (or a predefined value is used) taking into account the assumed transmission and processing delays in the UTRAN. Timing adjustment procedure on the control frames stream is then used to converge to the exact timing. Other solutions are FFS.

In case of connection using transcoder in the CN, a margin can (shall) be added to both the DL and UL offset in order to face possible variation of the transmission delay in the interfaces without causing frame slips. Margin in DL is created delaying/buffering DL data in RNC before sending the frames to the Node B, while margin in UL is created delaying/buffering the UL data before sending the transcoder frame to the CN.

Note : It is FFS if additional functionality should be introduced to improve the initial setting of DL offset values. (e.g. some background protocols)

6.1.19 Initial synchronisation of a additional soft handover branches

The initial synchronisation of a new branch is achieved using the timing adjustment procedure described above and applied to the lub/lur frames that are sent before the beginning of the DL data transmission in the new Uu port. The initial timing assumed by SRNC can be the timing used for the existing branch(es).

If the transmission delay for the new branch is higher than in the existing ones, the timing advance request from Node B can be fulfilled using increasing the UL and DL margin, if any (e.g. in case of connection using transcoder in the CN).

Note : It is FFS if additional functionality should be introduced to improve the initial setting of DL offset values. (e.g. some background protocols)

6.1.20 Maintaining offset

UE measures the offset also in the active Radio Links, and if changed, reports the new value to the UTRAN.

6.1.21 Synchronisation of L1 configuration changes

When a synchronised L1 configuration change shall be made, the SRNC commands the related node B's to prepare for the change. When preparations are completed and SRNC informed, serving RNC decides appropriate change time. SRNC tells the UEFN for the change by a suitable RRC message. The node B's are informed the CFN by NBAP Channel reconfiguration messages (name not yet agreed in SMG2 ARC) and/or RNSAP Radio Link Reconfiguration messages.

At indicated switch time UE and node B's change the L1 configuration.

Node Synchronisation

This describes how a common timing reference can be achieved between the UTRAN nodes.

Editor's note : It is likely that the method for Frame Synchronisation will depend on a numbering of the Iub/Iur DCH frames. Then there may be a need for the UTRAN nodes (RNC and Node B) to have a common timing reference.

Avoiding dependence to an external system to provide this means that there is a need for UTRAN specific solutions. If the Network Synchronisation above is very good, the drift between different nodes is slow, but will occur. Therefore, some kind of protocols over Iur and Iub need to be specified to detect and correct a possible misalignment of the Node Synchronisation. The needed accuracy need to be identified.

The architecture may have several solutions: separate synchronisation node, hierarchical synchronisation relation between RNCs and RNC-Node B, mutual synchronisation between RNCs etc.

Positioning / Localisation functions may also set requirements on this Node Synchronisation.

[TDD - Node Synchronisation and Frame synchronisation are used within neighbouring cells to minimise cross-interference (Node B-Node B, UE-UE, Node B-UE cross-interferences)]

UTRAN OA&M Requirements

OA&M of Node B

Editor's Note : Section 8.1 and subsections of [1]

The O&M of Node B is separated in two parts : the O&M linked to the physical and software implementation of Node B, denoted the *physical O&M*, and the O&M of the logical resources that the Node B contains, denoted *logical O&M*. The RNS architecture with the O&M interfaces is shown in Figure 13.

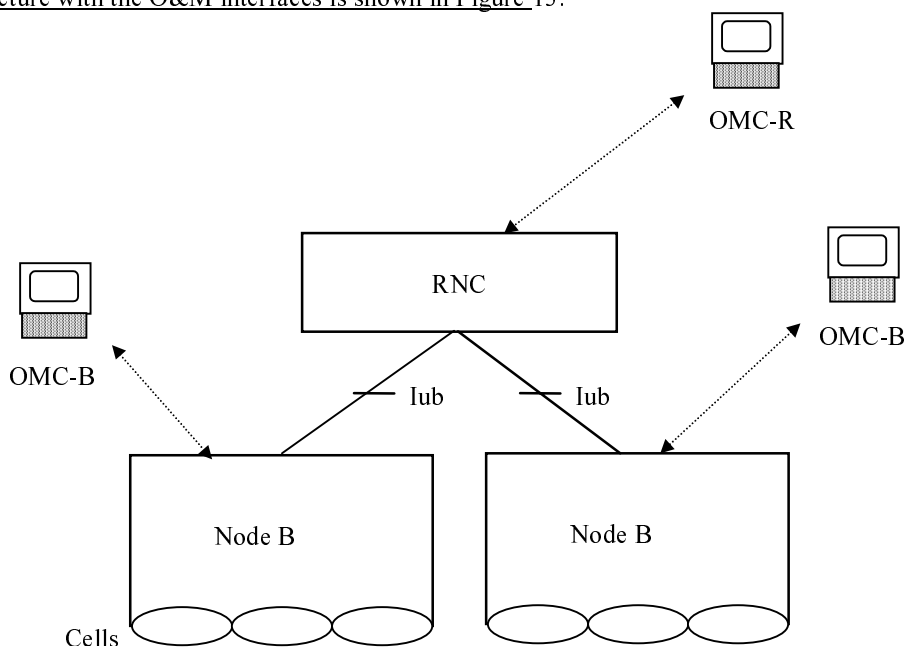

Figure 13. RNS architecture with O&M interfaces

Note : The definition of OMC-R is FFS.

Note : The architecture of the RNS, as shown in that figure includes the notion of OMC-B, as the O&M entity for the Node B, as well the OMC-R, as the O&M entity for the RNC. These notions are logical notions that will be further refined in SMG6.

Two OMC-B are shown, although this does not imply a physical separation, but only a logical separation. This means that when both Node B are from the same manufacturer, it can be expected that both logical entities reside in the same physical entity. Similarly, the OMC-R and OMC-B may be physically integrated when both RNC and Node B are from the same vendor, which ends up being close to a typical GSM implementation.

The protocols on the RNC to OMC-R and Node B to OMC-B interfaces are outside the scope of SMG2.

6.1.22 Physical O&M

The physical O&M functions are heavily dependent on the implementation of Node B, both for its hardware components and for the management of the software load on these components. It needs therefore to be implementation dependent, and be performed between Node B and a dedicated OMC-B

This means that the standardisation in SMG2 should only address the transport of O&M signalling between the OMC-B and Node B. This transport can be performed by several means :

- it may involve the RNC as a relay function
- it may be performed across dedicated PVCs between Node B and OMC-B. These PVCs can be provided by administrative means. These PVCs potentially being across the RNC, but not necessarily
- it may be performed across dedicated SVCs between Node B and OMC-B. This is therefore a service of the transport functions

6.1.23 Logical O&M

The Node B provides at the minimum access to a set of logical resources e.g. ports both on the Iub interface and on the Uu (radio) interface. These logical resources are controlled by the RNC on the Iub interface by the Traffic management functions.

Since the RR layer is probably within the RNC, the RNC should know about the availability status of a given cell. Similarly, it would be beneficial that the RNC has a view of the available radio resources for each cell. This is compatible with the fact that the RR layer is responsible for the management of the system load in interferences in particular at the RNS level.

The management of these logical resources is desirable (but it should be noted that it is not absolutely necessary) for the proper operation of the RNS. Actually, the Radio Resource algorithms within the RNC can only be optimised with the knowledge of the available logical resources within each Node B of the RNS. Actually, because of soft handover, some knowledge on neighbour RNS may be beneficial as well.

The management of the logical resources of Node B needs to be performed on the Iub interface. In order to reach that objective, it is necessary that a logical model of Node B is defined, and then the procedures to manage these resources will be defined on the Iub.

UTRAN Interfaces

External Interfaces

6.1.24 Uu Interface

Editor's Note : The radio interface protocol architecture is to be described by the 3GPP TSG RAN WG2. This section should contain a description of the radio interface protocol architecture aligned with the Radio Interface Expert Group, and additional assumptions when needed. ~~Section 12.2 of [1]~~

6.1.25 Iu Interface

6.1.25.1 Iu Overview

Editor's Note : ~~Section 12.3 and subsections of [1]~~—This will probably need some cleaning and restructuring work.

From a UTRAN perspective, maximising the commonality of the various protocols that flow on the Iu interface is desirable. This means at the minimum that :

- A common set of radio access bearer services will be offered by UTRAN to the Core Network nodes, regardless of their type (e.g. 3G-MSC or 3G-SGSN).
- There will be a common functional split between UTRAN and the Core Network nodes, regardless of their type (e.g. 3G-MSC or 3G-SGSN).

6.1.26 Streamlining functions

6.1.26.1 Access Network Triggered Streamlining

One Access Network triggered function needed over the Iu interface is the function for SRNS Relocation. SRNS Relocation needs support from the Core Network to be executed.

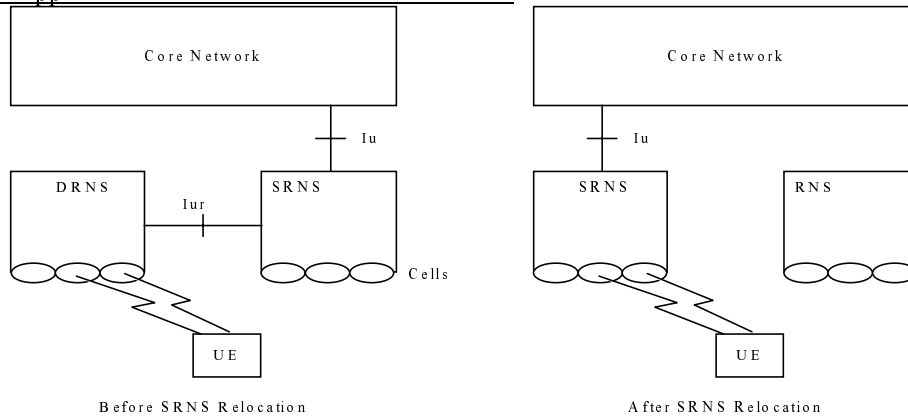

Figure 14. Serving RNS Relocation

[FDD — For the cases where handover can be performed independently from SRNS Relocation, the algorithm for triggering the SRNS relocation is not specified.]

[FDD — The specification of Iur Interface shall allow the support of soft handover throughout the UTRAN of PLMN without performing SRNS relocation.]

6.1.26.2 Core Network Triggered Streamlining

For Further Studies

6.1.26.3 Iu Protocols

Various transmission possibilities exist to convey the bearers over the Iu to the Core Network. Therefore, the Data Transport Resource and traffic handling are separated from the RANAP (Figure 15.). This resource and traffic handling is controlled by the Transport Signalling. The Transport Signalling is carried by a Signalling Bearer over the Iu interface.

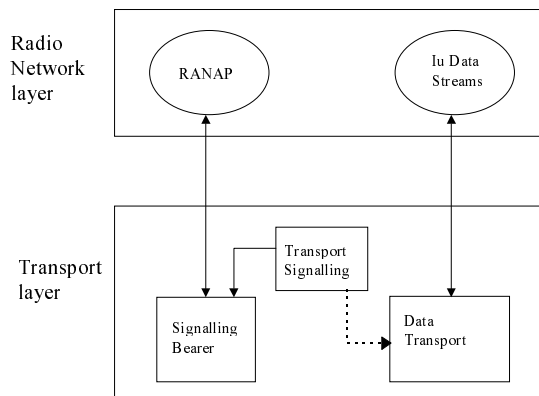

Figure 15. Separation of RANAP and transport over Iu

6.1.26.3.1 Radio Application Protocol

Editor's Note : Section 12.4 of [1] except for the signalling bearer for Q.aal2 which should be placed in section 12.1.2 and the Q.aal2 which will be placed in the following section.

The Radio Network signalling over Iu consists of the Radio Access Network Application Part (RANAP). The RANAP consists of mechanisms to handle all procedures between the CN and UTRAN. It is also capable of conveying messages transparently between the CN and the UE without interpretation or processing by the UTRAN.

Over the Iu interface the RANAP protocol is, e.g. used for:

- Facilitate a set of general UTRAN procedures from the Core Network such as paging -notification as defined by the notification SAP in [2].
- Separate each User Equipment (UE) on the protocol level for mobile specific signalling management as defined by the dedicated SAP in [2].
- Transfer of transparent non-access signalling as defined in the dedicated SAP in [2].
- Request of various types of UTRAN Radio Access Bearers through the dedicated SAP in [2].
- Perform the streamlining function.

The Radio Access Bearers are provided by the Access Stratum

Editor's note : Reference has to be made to the Radio Interface Protocol Architecture document from the L23 expert group.

6.1.26.3.2 ALCAP Protocol

Editor's Note : Q.aal2 part of Section 12.4 of [1]

Q.aal2 is used as the ALCAP protocol for dynamically setup ALL-2 connections over Iu towards the PSTN Domain.

Note : This ALCAP protocol is based on the working assumption that the CODECs are located in the Core Network. If the CODECs are located in UTRAN, this will have to be reconsidered.

Internal Interfaces

6.1.27 Iur Interface

6.1.27.1 Iur Overview

Editor's Note : Section 12.5.1 of [1]

The Iur interface connects a SRNS and a DRNS.

This interface should be open.

The information exchanged across the Iur is categorised as below :

- One or more Iur Data stream which comprises
 - Transport Block Sets
 - Simple, commonly agreed Quality estimate
 - Synchronisation information

There exist Iur CCH, DSCH and DCH data streams.

Note : CCH and DSCH management over Iur is study Item ARC/1

- Signalling
 - Addition of Cells in the DRNS which may lead or not to the addition of a new Iur Data stream
 - Removal of Cells in the DRNS
 - Modify Radio link characteristics

Note : This list of procedures is not the full list over Iur interface.

From a logical stand point, the Iur interface is a point to point interface between the SRNS and all the DRNS, i.e. there is no deeper hierarchy of RNSs than the SRNS and DRNS. However, this point to point logical interface should be feasible even in the absence of a physical direct connection between the two RNSs.

6.1.27.2 Functional split over Iur

Editor's Note : Section 12.5.1.1 and subsections of [1]

Note: This is only an initial list.

6.1.27.2.1 Macro-diversity Combining/Splitting

DRNS may perform macro-diversity combining/splitting of data streams communicated via its cells. SRNS performs macro-diversity combining/splitting of Iur data streams received from/sent to DRNS(s), and data streams communicated via its own cells.

The internal DRNS handling of the macro-diversity combining (respectively splitting) of Iub (respectively Iur) DCH frames is controlled by the DRNS.

6.1.27.2.2 Control of Macro-diversity Combining/Splitting Topology

When requesting the addition of a new cell for a UE-UTRAN connection, the RNC of the SRNS (i.e. the SRNC) can explicitly request to the RNC of the DRNS (i.e. the DRNC) a new Iur data stream, in which case the macro-diversity combining and splitting function within the DRNS is not used for that cell. Otherwise, the DRNS takes the decision whether macro-diversity combining and splitting function is used inside the DRNS for that cell i.e. whether a new Iur data stream shall be added or not.

6.1.27.2.3 Handling of DRNS Hardware Resources

Allocation and control of DRNS hardware resources, used for Iur data streams and radio interface transmission/reception in DRNS, is performed by DRNS.

6.1.27.2.4 Allocation of Downlink Channelisation Codes

Allocation of downlink channelisation codes of cells belonging to DRNS is performed in DRNS.

Editors note: Note that this does not imply that the signalling of the code allocation to the UE must be done from the DRNS.

6.1.27.2.5 UpLink Power Control

This group of functions controls the level of the uplink transmitted power in order to minimise uplink interference and keep the quality of the connections. If the connection involves both a SRNS and a DRNS the function UL Outer Loop Power Control (located in the SRNC) sets the target quality for the UL Inner Loop Power Control function (located in Node B). Additional quality information for the case when macro diversity combining is performed in DRNC is for further study.

Note : some additional function is needed for resource negotiation between the SRNS and the DRNS across the Iur. This is FFS.

6.1.27.2.6 Down-Link Power Control

This group of functions controls the level of the downlink transmitted power in order to correct the downlink power drifting between several radio links. SRNC regularly (or under some algorithms) sends the target down link power range based on the measurement report from UE.

6.1.27.2.7 Admission Control

Admission control in a DRNC is implicitly invoked during radio link setup/modify.

Information on UL interferences and DL power on cells controlled by the DRNC should be available across Iur.

Additional information exchanges between admission control functions located in different RNCs are for further study.

6.1.27.3 DRNS logical Model over Iur

Editor's Note : Section 12.5.1.2 and subsections of [1]

6.1.27.3.1 Overview

The model in Figure 16, shows the Drift Radio Network System as seen from the SRNC. It is modelled as a "black box" with a set of Radio Links on the Uu side of the box and another set of User Plane access ports on the Iur side of the box. The Radio Links are connected to the Iur user ports via the internal transport mechanisms of the DRNS. Operations for controlling the connections between ports are sent from the SRNC to the DRNC via an Iur Control Plane port.

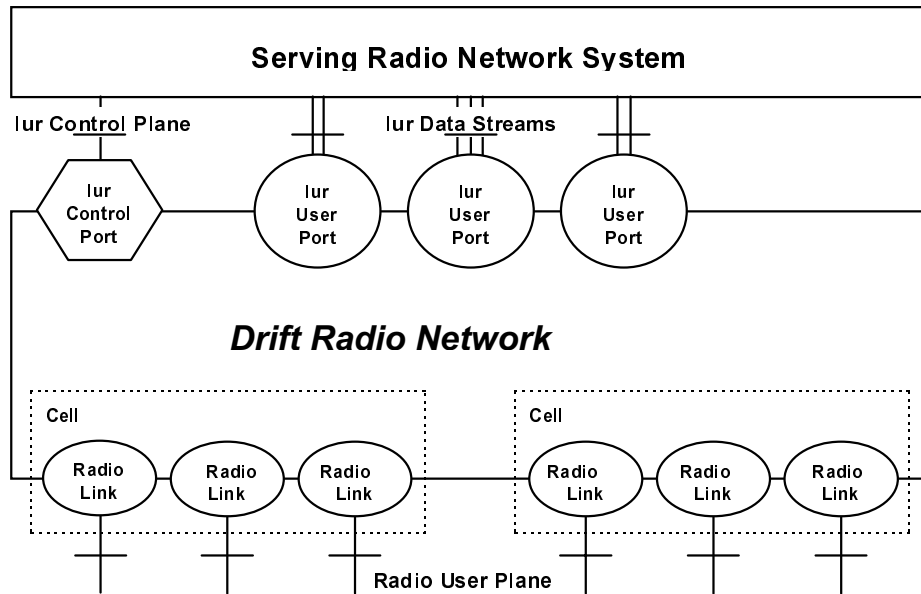

Figure 16. Drift RNS Logical Model

Note : This figure is the Radio Network layer view and not the transport layer one.

6.1.27.3.2 Logical Model Elements

6.1.27.3.2.1 Radio Link

A Radio Link represents a User Plane access point on the UTRAN side of the Uu interface between the User Equipment and the UTRAN. It is associated with :

- a Cell identifier.
- a Radio Frequency Carrier identifier.
- a Physical Channel identifier (spreading code).

The semantics of a Radio Link include the following:

- It is created and destroyed by administrative procedures when a cell site and/or RF carrier is added to, or deleted from, the RNS.
- It can be attached to one and only one Iur User Port at any given time.
- Its resources are allocated and controlled by the DRNS.

6.1.27.3.2.2 Cell

A Cell is a collection of Radio Links found at a specific location. It is defined by:

- a Cell identifier.

The semantics of a Cell include the following:

- It is created and destroyed by administrative procedures when a cell site and/or RF carrier is added to, or deleted from, the RNS.

6.1.27.3.2.3 Iur Data Stream

One and one only Iur DCH data stream is associated with a transport bearer channel identifier.

The association for Iur CCH data stream is FFS.

6.1.27.3.2.4 Iur User Port

An Iur User Port represents a User Plane access point on the Iur interface between the SRNS and DRNS. It is associated with one or more Iur data streams.

The semantics of an Iur User Port include the following:

- It is created and destroyed by administrative procedures when transport facilities are added to, or deleted from, the Iur interface between the SRNS and DRNS. It can also be created and destroyed dynamically using ATM SVCs to add or remove transport facilities.
- It is assigned and released by the SRNC in reaction to requests for bearer services from the UE.
- It may be attached to one or more Radio Links. When attached to Radio Links in the downlink direction, it acts as a

point-to-multipoint connection for diversity transmission. When attached to multiple Radio Links in the uplink direction, it acts as a multipoint-to-point connection for diversity reception.

- The transmit and receive diversity resources required to implement the point-to-multipoint and multipoint-to-point connections are controlled by the DRNS.
- The Iur User Stream emanating from the Iur User Port terminates in the SRNS connected to DRNS.

6.1.27.3.2.5 Iur Control Port

An Iur Control Port represents the Control Plane access point on the Iur interface between the SRNS and the DRNS. It is defined by:

- a transport bearer channel identifier.

The semantics of an Iur Control Port include the following:

- It is created via administrative procedures when the Iur interface is created.

6.1.27.4 Iur Protocols

Editor's Note : Section 12.5.1.3 of [1]

The signalling information across Iur interface as identified in section 6.1.27.1 Iur Overview is called Radio Network Subsystem Application Part (RNSAP).

The RNSAP is terminated in the SRNC and in the DRNC.

As already stated in Section General principles there shall exist a clear separation between the Radio Network Layer and the Transport Layer. Therefore, the Data Transport resource and traffic handling are separated from the RNSAP (Figure 17.). This resource and traffic handling is controlled by the Transport Signalling. The Transport Signalling is carried by a Signalling Bearer over the Iur interface.

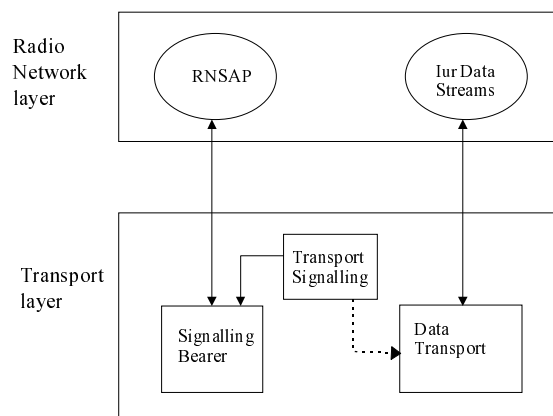

Figure 17. Separation of RNSAP and transport over Iur

6.1.28 Iub Interface

6.1.28.1 Iub Overview

Editor's Note : Section 12.5.2 of [1]

The Iub interface connects a RNC and a Node B.

The information transferred over the Iub reference point can be categorised as follows:

1. Radio application related signalling
The Iub interface allows the RNC and the Node B to negotiate about radio resources, for example to add and delete cells controlled by the Node B to support communication of the dedicated connection between UE and SRNC. Information used to control the broadcast and paging channels, and information to be transported on the broadcast and paging channels, belong to this category also.
2. Iub/Iur DCH data stream
The Iub interface provides means for transport of uplink and downlink DCH Iub frames between RNC and Node B. The DCH Iub frame header includes uplink quality estimates and the Connection Frame Number (CFN). The DCH Iub frame body comprises of data to be transferred over the radio interface. The DCH Iub frames can be carried on pre-defined transmission links or switched connections.
One Iub/Iur DCH data stream is carried on one transport bearer.

3. Iub RACH data stream
The Iub interface provides means for transport of uplink RACH transport frames between RNC and Node B. The RACH transport frame header includes the Cell Frame Number (FNCell). The RACH transport frame body includes the data received over radio interface. The transport frames can be carried on pre-defined transmission links or switched connections. One Iub RACH data stream is carried on one transport bearer.
For each RACH in a cell, an Iub RACH data stream must be established over the Iub interface.
 4. Iub FACH data stream
The Iub interface provides means for transport of downlink FACH transport frames between RNC and Node B. The FACH transport frame header includes the Cell Frame Number (FNCell). The FACH transport frame body includes the data to be sent over radio interface. The transport frames can be carried on pre-defined transmission links or switched connections. One Iub FACH data stream is carried on one transport bearer.
For each FACH in a cell, an Iub FACH data stream must be established over the Iub Interface.
 5. Iub DSCH data stream
The Iub interface provides the means for transport of downlink shared channel, DSCH, data frames between RNC and Node B. The DSCH Iub frame body comprises of data to be transferred over the radio interface. The Iub DSCH frames can be carried on pre-defined transmission links or switched connections.
One Iub DSCH data stream is carried on one transport bearer.
- The Iub DCH data stream shall follow the same specification as the Iur DCH data stream.
Over the Iub interface between the RNC and one Node B, one or more Iub data streams are established, each corresponding to one or more cells belonging to the Node B.

6.1.28.2 Functional split over Iub

Editor's Note : Section 12.5.2.2 and subsections of [1]

Note: This is only an initial list.

6.1.28.2.1 Traffic management

6.1.28.2.1.1 Management of dedicated resources

These functions are related to the activation of logical resources (e.g. Radio Links, Iub ports), and the connection of these various resources together.

Some freedom may be left to Node B on some functions like allocation of codes or soft combining within Node B, since soft combining has merits for being executed as close as possible to the radio (both in terms of transmission cost and efficiency). This is FFS.

In particular it is FFS whether the allocation of channelisation codes is done by the Controlling RNC or by the Node B

6.1.28.2.1.2 Management of common radio channels

The common channels need to be controlled from the RNC. This is typically the control of the RACH channel, the information which is broadcast on the Broadcast control channel, and the control and request for sending information on the paging channels.

6.1.28.2.1.3 Control of traffic flows

Congestion on the Iub interface will need to be covered for asynchronous flows (i.e. those which may flow via AAL5). This concerns in particular the flow from radio channels where retransmission takes place in Node B and where soft handover is not applied.

6.1.28.2.2 Macro-diversity Combining of Radio Frames

Node B may perform macro-diversity combining/splitting of data streams communicated via its cells. RNC performs macro-diversity combining/splitting of Iub data streams received from/sent to several Node B(s).

6.1.28.2.3 Control of Macro-diversity Combining/Splitting Topology

When requesting the addition of a new cell for a UE-UTRAN connection, the RNC can explicitly request to the Node B a new Iub data stream, in which case the macro-diversity combining and splitting function within the Node B is not used for that cell. Otherwise, the Node B takes the decision whether macro-diversity combining and splitting function is used inside the Node B for that cell i.e. whether a new Iub data stream shall be added or not.

The internal Node B handling of the macro-diversity combining/splitting of radio frames is controlled by the Node B.

6.1.28.2.4 Soft Handover Decision

To support mobility of the UE to UTRAN connection between cells, UTRAN uses measurement reports from the UE and detectors at the cells. The mechanisms for this are FFS.

The RNC takes the decision to add or delete cells from the connection.

6.1.28.2.5 Handling of Node B Hardware Resources

Mapping of Node B logical resources onto Node B hardware resources, used for Iub data streams and radio interface transmission/reception, is performed by Node B.

6.1.28.2.6 Allocation of Downlink Channelisation Codes

Whether the Allocation of downlink channelisation codes of cells belonging to Node B is performed in the Controlling RNC or in the Node B is FFS.

Note : Allocation of DL Channelisation codes is study Item ARC/2

Editors note: Note that this does not imply that the signalling of the code allocation to the UE must be done from the Controlling RNC nor the Node B.

6.1.28.2.7 UpLink Power Control

This group of functions controls the level of the transmitted power in order to minimise interference and keep the quality of the connections. The function UL Outer Loop Power Control located in SRNC sets the target quality for the UL Inner Loop Power Control function located in Node B.

6.1.28.2.8 Down-Link Power Control

This group of functions controls the level of the downlink transmitted power in order to correct the downlink power drifting between several radio links. SRNC regularly (or under some algorithms) sends the target down link power range based on the measurement report from UE.

6.1.28.2.9 Admission Control

The Admission Control function based on UL interference and DL power is located in the Controlling RNC.

The Node B shall be able to report UL interference measurements and DL power information over Iub.

The Controlling RNC controls this reporting function, i.e. if these information need to be reported and the period of these reports.

Note : Other parameters for Admission Control are FFS.

Note : The possibility to have this Admission Control function in Node B is FFS.

6.1.28.3 Node B logical Model over Iub

Editor's Note : Section 12.5.2.3 and subsections of [1]

The model described in Figure 18. shows the Node B as seen from the controlling RNC. The model includes:

- the logical resources provided by Node B to UTRAN (via its Controlling RNC)
- the dedicated channels which have been established on Node B
- the common channels that Node B provides to the RNC

The procedures for controlling the connections between radio links and Iub DCH data ports are sent from the RNC to the Node B via the Communication Control Ports.

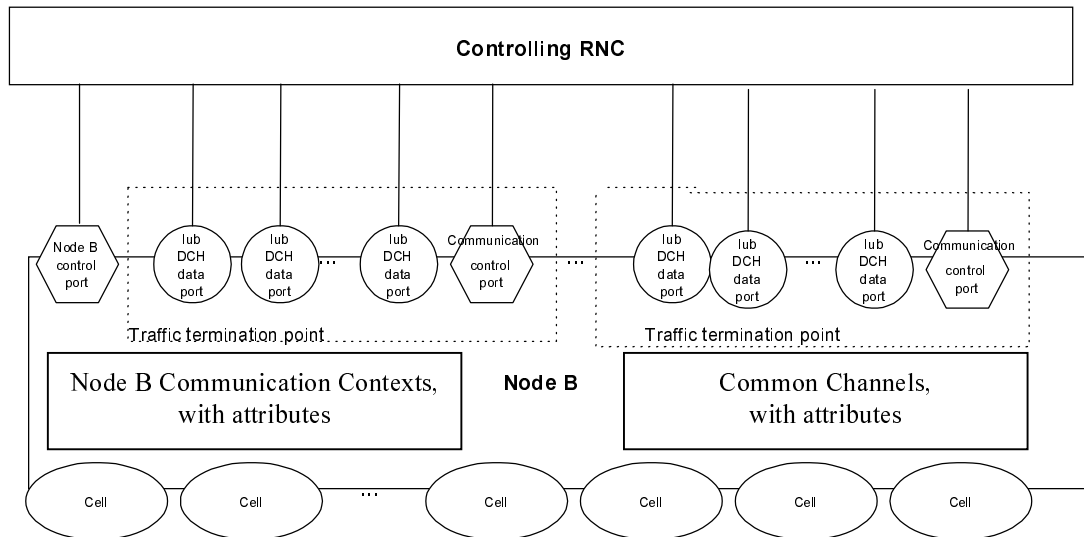

Figure 18. Logical Model of Node B

6.1.28.3.1 Elements of the logical model

6.1.28.3.1.1 Radio Network Logical resources

1. **Cell :**

The notion of cell is the same as defined for the DRNC. Node B may have one or more cells.

6.1.28.3.1.2 Transport network logical resources

1. **Node B Control Port**

The Node B Control Port is used to exchange the signalling information for the logical O&M of Node B resources, the creation of Node B Communication Contexts, the configuration of the common transport channels that Node B provides in a given cell, PCH and BCH control information between the RNC and the Node B. The Node B Control Port corresponds to one signalling bearer between the controlling RNC and the Node B. Whether there a Node B can have multiple Node B Control Ports (multiple signalling bearers), e.g. for load sharing or redundancy purposes, is FFS.

2. **Communication Control Port**

A Communication Control Port corresponds to one signalling bearer between the RNC and Node B for the control of Node B Communication Contexts. Node B may have multiple Communication Control Ports (one per Traffic Termination Point). The Communication Control Port is selected at creation of the Node B Communication Context.

3. **Traffic Termination Point**

Traffic Termination Point represents DCH data streams belonging to one or more Node B Communication Contexts (UE contexts), which are controlled via one Communication Control Port. The Traffic Termination Point is thus a descriptive entity which neither is controlled over Iub nor by O&M.

4. **Iub DCH Data Port**

An Iub DCH Data Port represents a user plane bearer (carrying one Iub DCH Data Stream) between the Node B and RNC.

6.1.28.3.1.3 Node B Communication Contexts for Dedicated Channels

A Node B Communication Context corresponds to all the dedicated resources which are necessary for a user in dedicated mode and using dedicated channels as restricted to a given Node B.

There are a number of Node B Communication Contexts inside a given Node B.

The attributes to a Node B Communication Context are the following (not exhaustive):

- The list of Cells where dedicated physical resources are used
- The list of DCH which are mapped on the dedicated physical resources for that Node B Communication Context
- For each DCH, the complete characteristics as defined in [8]
- The list of Iub DCH Data Ports
- For each Iub DCH Data Port, the corresponding DCH and cells which are carried on this data port
- Physical layer parameters (outer loop power control, etc)

6.1.28.3.1.4 Common Channels

A Common Channel corresponds to a radio Common Channel as configured by the Node B.

The BCCH and the PCCH are carried directly on the Node B control port using NBAP procedures. These Common Channels will not be mapped to individual data ports.

the RACH and the FACH (and possibly the DSCH, FFS) will have an associated Iub data port similar to an Iub DCH data port for a dedicated channel (i.e. AAL2 transport is used).

The attributes of a Common channel are (not exhaustive)

- Type
- Cell (only one)
- Associated Iub data port (if applicable)
- Physical parameters

6.1.28.4 Iub Protocols

Editor's Note : Section 12.5.2.4 of [1]

As already stated in section General principles there shall exist a clear separation between the radio network layer and the transport layer. Therefore, the radio Network signalling and Iub data streams are separated from the data transport resource and traffic handling as show in Figure 19.. This resource and traffic handling is controlled by the Transport Signalling. The Transport Signalling is carried by a Signalling Bearer over the Iub interface.

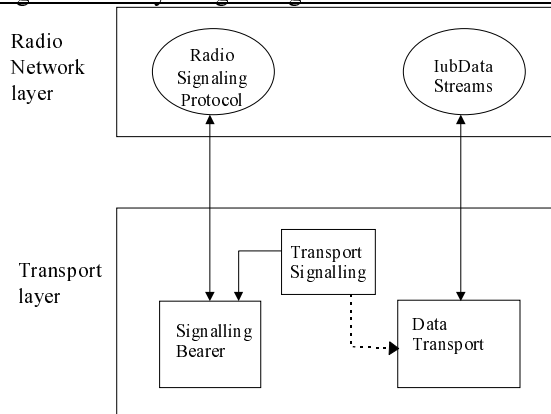

Figure 19. Separation of Radio Network protocols and transport over Iub

Protocol Model (Informative)

The following section is a informative section which aim is to provide an overall picture of how the MAC layer is distributed over Uu, Iub and Iur for the RACH, FACH and DCH.

6.1.29 RACH Transport Channel

Figure 20. shows the protocol stack model for the RACH transport channel when the Controlling and Serving RNC are co-incident.

For the RACH transport channel, Dedicated MAC (MAC-d) uses the services of Common MAC (MAC-c).

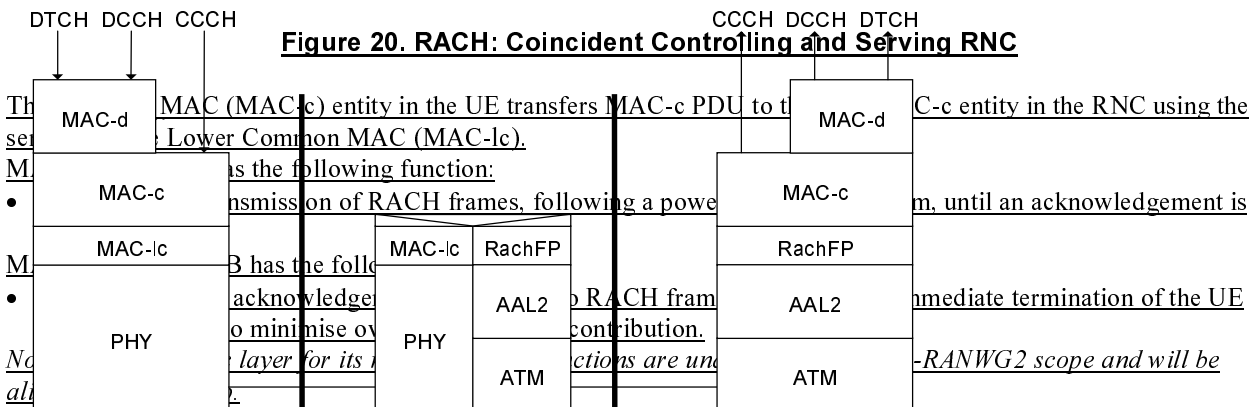

An Interworking Function (IWF) in the NodeB interworks the RACH from the UE into the RACH

Frame Protocol (RACH FP) entity.

The RACH Frame Protocol entity adds header information to form a RACH FP PDU which is transported to the RNC over an AAL2 (or AAL5) connection.

At the RNC, the RACH FP entity delivers the MAC-c PDU to the MAC-c entity.

Figure 21. shows the protocol model for the RACH transport channel with separate Controlling and Serving RNC. In this case, the RACH Frame Protocol (DchFP) is used to interwork the Common MAC (MAC-c) at the Controlling RNC with the Dedicated MAC (MAC-d) at the Serving RNC (The exact Iur RACH Frame Protocol is FFS)

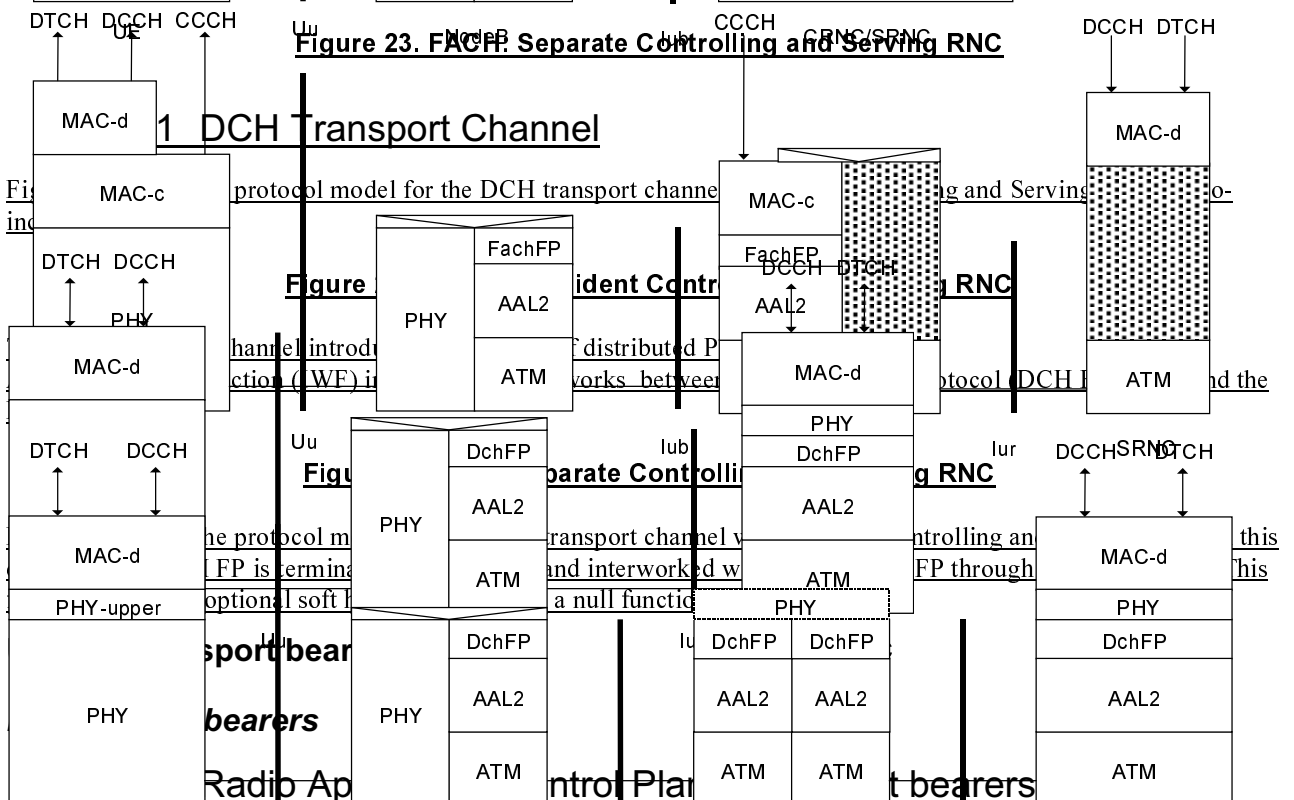
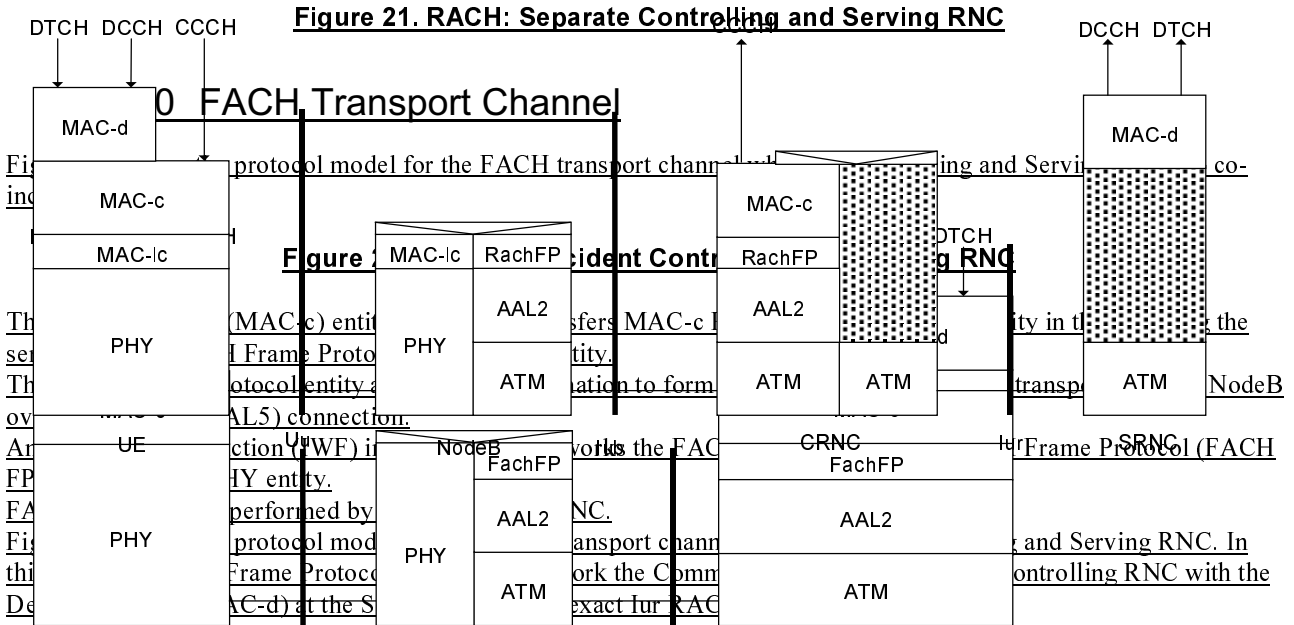

Editor's Note : Section 13.2.1 of [1]

Over the Iu interface the RANAP protocol requires:

- A connectionless transport of RANAP messages to facilitate e.g. Paging.
- A connection oriented transport of RANAP messages e.g. to facilitate messages belonging to a specific User equipment (UE) during a call.

- A reliable connection to make the RANAP simpler.
- Support of signalling inactivity testing of a specific UE connection.

RANAP shall allow different kinds of addressing schemes to be used for the signalling bearer.

6.1.33 Transport Network Control Plane Transport bearers

Editor's Note : Last paragraph and note of Section 12.4 of [1]

MTP3B/SAAL-NNI is selected as the standard signalling transport bearer for Qaal2 over Iu.

Note : This ALCAP protocol and signalling bearer are based on the working assumption that the CODECs are located in the Core Network. If the CODECs are located in UTRAN, this will have to be reconsidered.

6.1.34 User Plane Transport bearers

Iur Transport bearers

6.1.35 Radio Application Control Plane Transport bearers

Editor's Note : Section 13.2.2 and subsection of [1] This section will need some cleaning and parts should be moved in other sections.

There exist at least two major types of soft handover over the Iur interface:

1. The case when a new physical transmission (Iur data stream) is set up over the Iur interface to provide an additional cell.
2. The case when existing transmission (Iur data stream) is used over the Iur interface when an additional cell is added in the DRNS. In this case, the DRNS must be able to identify the UE in order to perform the adding of the cell. Consequently, a UE context must exist in the DRNS.

Over the Iur interface the RNSAP protocol requires:

- A connection oriented transport of RNSAP messages, i.e. one signalling bearer connection for each DRNS for a particular UE.
- A reliable connection to make the RNSAP simpler.
- Support of signalling inactivity testing of a specific UE connection.

6.1.35.1 Addressing of RNSs over the Iur Interface

- For an RRC connection using a dedicated channel, the Iur standard shall allow the addition / deletion of cells belonging to any RNS within the PLMN.
- The specification of the Iur interface shall allow the SRNC (i.e. the RNC of the SRNS) to address any other RNC in the PLMN for establishing a signalling bearer over Iur.
- The specification of the Iur interface shall allow the SRNC (i.e. the RNC of the SRNS) to address any other RNC within the PLMN for establishing user data bearers for Iur data streams.

Note : Connectionless RNSAP over Iur is for further studies.

RNSAP shall allow different kinds of addressing schemes to be used for the signalling bearer.

6.1.36 Transport Network Control Plane Transport bearers

Editor's Note : Section 13.2.3 of [1]

MTP3B/SAAL-NNI is used as signalling bearers for the Transport Network Control Plane Signalling on the Iur.

6.1.37 User Plane Transport bearers

Editor's Note : Section 13.1 of [1]

ATM and AAL type 2 (I363.2 and I.366.1) is used as the standard transport layer for Soft Handover data stream across the Iur interface. Other protocols, such as Frame Relay and AAL5, are FFS.

Iub Transport bearers

6.1.38 Radio Application Control Plane Transport bearers

6.1.39 Transport Network Control Plane Transport bearers

6.1.40 User Plane Transport bearers

Editor's Note : Section 13.1 of [1]

ATM and AAL type 2 (I363.2 and I.366.1) is used as the standard transport layer for Soft Handover data stream across the Iub interface. Other protocols, such as Frame Relay and AAL5, are FFS.

UTRAN Performance Requirements

Delay Requirements

6.1.41 UTRAN delay requirements

The maximum transmission delay of a diversity branch and the maximum processing delay introduced by single UTRAN network elements shall be defined.

Appendices

~~A Informative Annexe : Protocol Stacks for Distributed MAC~~

Editor's Note : Annexe A from [1]

History

Document history		
0.0.1	February 1999	Document Structure Proposal
<u>0.0.2</u>	<u>February 1999</u>	<ul style="list-style-type: none"> <u>Use of 3GPP Template</u> <u>Introduction of content from the Merged UTRAN Architecture Description</u>
<u>0.0.3</u>	<u>February 1999</u>	<u>Annexe A : Protocol Stacks for Distributed MAC moved to section "Protocol Model (Informative) Protocol Model".</u>

Rapporteur for 3GPP RAN S3.01 is:

Jean Marie Calmel
Nortel Wireless Networks
Tel. : +33 1 39 44 52 82
Fax : +33 1 39 44 50 54
Email : **Error! Bookmark not defined.**

This document is written in Microsoft Word version 97