

TSG-RAN meeting #3

RP#3(99)197

Agenda:

Source: RAN WG3

Title: S3.13: RANAP Specification, v. 0.1.0

TS RAN S3.13 V0.1.0 (1999-04)

Technical Specification

**3rd Generation Partnership Project (3GPP);
Technical Specification Group (TSG) RAN
RANAP Specification**

[UMTS <spec>]

3GPP

Reference

<Workitem> (<Shortfilename>.PDF)

Keywords

<keyword[, keyword]>

3GPP

Postal address

Office address

Internet

secretariat@3gpp.org

Individual copies of this deliverable
can be downloaded from

<http://www.3gpp.org>

Copyright Notification

No part may be reproduced except as authorized by written permission.
The copyright and the foregoing restriction extend to reproduction in all media.

©
All rights reserved.

Contents

Intellectual Property Rights	6
Foreword	6
1 Scope	6
2 References	6
3 Definitions, symbols and abbreviations	6
3.1 Definitions.....	6
3.2 Symbols.....	7
3.3 Abbreviations.....	7
4 General.....	7
5 RANAP Services	7
6 Services expected from signalling transport.....	7
7 Functions of RANAP.....	7
8 RANAP procedures	7
8.1 Serving RNS relocation	7
8.2 Inter RNS hard handover	9
8.3 Radio Access Bearer Assignment	12
8.4 Iu Release.....	20
8.4.1 Iu Release due to completion of transaction between UE and CN	21
8.4.2 Iu Release due to UTRAN generated reasons	21
8.4.3 Iu Release due successful handover or SRNS relocation	22
8.5 Overload Control	22
8.5.1 Philosophy.....	22
8.5.2 Overload at the CN.....	23
8.5.3 Overload at the UTRAN.....	23
8.5.4 Message throughput congestion	24
8.6 Reset	24
8.6.1 Reset at the UTRAN.....	24
8.6.2 Reset at the CN.....	24
8.6.3 Abnormal Conditions	25
8.6.3.1 Abnormal Condition at the UTRAN.....	25
8.6.3.2 Abnormal Condition at the CN	25
8.6.3.3 Crossing of Reset messages	25
8.7 Common Id	25
8.8 Paging	26
8.9 Trace Invocation	26
8.10 Cipher Mode Control	27
8.10.1 Successful operation.....	27
8.10.2 Abnormal conditions	28
8.11 CN Information Broadcast	28
8.12 Direct Transfer.....	29
8.13 Initial UE Message.....	29
9 Elements for RANAP communication	30
9.1 Message functional definition and content.....	30
9.1.1 Message Contents.....	31
9.1.1.1 RADIO ACCESS BEARER SETUP (FFS).....	31
9.1.1.2 RADIO ACCESS BEARER SETUP RESPONSE (FFS).....	31
9.1.1.3 RADIO ACCESS BEARER SETUP FAILURE (FFS).....	32
9.1.1.4 RADIO ACCESS BEARER RECONFIGURATION (FFS)	32
9.1.1.5 RADIO ACCESS BEARER RECONFIGURATION RESPONSE (FFS)	32
9.1.1.6 RADIO ACCESS BEARER RECONFIGURATION FAILURE (FFS).....	33
9.1.1.7 RADIO ACCESS BEARER RELEASE (FFS).....	33

9.1.1.8	RADIO ACCESS BEARER RELEASE RESPONSE (FFS).....	33
9.1.1.9	RADIO ACCESS BEARER RELEASE REQUEST	33
9.1.1.10	COMMON ID.....	34
9.1.1.11	DIRECT TRANSFER	34
9.1.1.12	INITIAL UE MESSAGE.....	34
9.1.1.13	CIPHER MODE COMMAND	35
9.1.1.14	CIPHER MODE COMPLETE	35
9.1.1.15	CIPHER MODE REJECT	35
9.1.1.16	PAGING	35
9.1.1.17	IU RELEASE COMMAND	36
9.1.1.18	IU RELEASE COMPLETE.....	36
9.1.1.19	RELOCATION REQUIRED.....	36
9.1.1.20	RELOCATION REQUEST	36
9.1.1.21	RELOCATION COMPLETE.....	37
9.1.1.22	RNC RELOCATION FAILURE.....	37
9.1.1.23	HANDOVER REQUIRED.....	37
9.1.1.24	HANDOVER REQUEST	38
9.1.1.25	HANDOVER REQUEST ACKNOWLEDGE	38
9.1.1.26	HANDOVER COMMAND.....	39
9.1.1.27	HANDOVER DETECT.....	39
9.1.1.28	HANDOVER COMPLETE.....	39
9.1.1.29	HANDOVER FAILURE	39
9.1.1.30	RESET.....	40
9.1.1.31	RESET ACKNOWLEDGE	40
9.1.1.32	CONFUSION	40
9.2	Message format and information element coding	40
9.2.1	RANAP coding standard.....	40
9.2.2	Signaling Element Coding.....	42
9.2.2.1	Message Type	44
9.2.2.2	Message Compatibility Information.....	45
9.2.2.3	Parameter Compatibility Information	45
9.2.2.4	Call ID	46
9.2.2.5	Bearer ID	46
9.2.2.6	User Information Rate	46
9.2.2.7	Information Transfer Capability	46
9.2.2.8	ATM Address	46
9.2.2.9	ATM Binding ID	46
9.2.2.10	Cause	46
9.2.2.11	RR Cause	47
9.2.2.12	MS Classmark for RAN.....	48
9.2.2.13	Direct transfer Information	48
9.2.2.14	Layer 3 Information	48
9.2.2.15	IMUI.....	49
9.2.2.16	TMUI.....	49
9.2.2.17	Cipher Information	49
9.2.2.18	Cell Identifier List.....	50
9.2.2.19	Cell Identifier.....	50
9.2.2.20	Chosen Channel	50
9.2.2.21	Cipher Response Mode.....	50
9.2.2.22	Chosen Cipher Algorithm	51
9.2.2.23	Group Call Reference	51
9.2.2.24	Talker Flag.....	51
9.2.2.25	Layer 3 Radio Information.....	51
9.2.2.26	Response Request	51
9.3	Timers	52

10 Handling of unknown, unforeseen and erroneous protocol data..... 52

11 Annex A (normative):..... 52

12 History 52

Intellectual Property Rights

Foreword

This Technical Specification has been produced by the 3rd Generation Partnership Project, Technical Specification Group <TSG name>.

The contents of this TS may be subject to continuing work within the 3GPP and may change following formal TSG approval. Should the TSG modify the contents of this TS, it will be re-released with an identifying change of release date and an increase in version number as follows:

Version m.t.e

where:

- m indicates [major version number]
- x the second digit is incremented for all changes of substance, i.e. technical enhancements, corrections, updates, etc.
- y the third digit is incremented when editorial only changes have been incorporated into the specification.

Scope

The present document ...

References

The following documents contain provisions which, through reference in this text, constitute provisions of the present document.

- References are either specific (identified by date of publication, edition number, version number, etc.) or non-specific.
- For a specific reference, subsequent revisions do not apply.
- For a non-specific reference, the latest version applies.
- A non-specific reference to an ETS shall also be taken to refer to later versions published as an EN with the same number.

Definitions, symbols and abbreviations

Definitions

For the purposes of the present document, the [following] terms and definitions [given in ... and the following] apply.

<defined term>: <definition>.

example: text used to clarify abstract rules by applying them literally.

Symbols

For the purposes of the present document, the following symbols apply:

<symbol> <Explanation>

Abbreviations

<ACRONYM> <Explanation>

General

[Editor's note: This chapter should describe requirements on RANAP forward/backward compatibility, error handling principles, message coding principles etc.]

RANAP Services

[Editor's note: This chapter should describe services of RANAP protocol.]

The RANAP offers the following services:

Services expected from signalling transport

[Editor's note: This chapter should describe expected services from signalling transport.]

Functions of RANAP

[Editor's note: This chapter should describe functions of RANAP protocol.]

RANAP procedures

Serving RNS relocation

[Editor's note: The contents of this chapter must be restructured to show the elementary procedures over the Iu interface. Also, it need to be aligned with the corresponding procedure in Signalling examples document.]

[Editor's note:

Study item Iu/2 has been solved. Signalling channel setup and setup response messages are not needed.

Study item Iu/3 has been solved. Relocation Proceeding 1 & 2 messages will be used.]

[Editor's note: Study item Iu/4 has been solved. No requirement for SRNS relocation to be triggered by the target RNS]

Serving RNS relocation is a procedure in which the serving RNS functionality of a specific RRC connection is relocated from one RNS to another without changing the radio resources or even without interrupting the user data flow.

When the serving RNS makes an algorithmic decision to relocate the serving RNS functionality to an other RNS a RANAP message to indicate that a Relocation is required is sent to the Core Network which is having an active RANAP connection related to the UE in question. This RELOCATION REQUIRED message includes essentially the target RNS identifier and an UTRAN information field (transparent to the core network).

Upon reception of the RELOCATION REQUIRED message the core network element should check whether the relocation is possible to be performed (This check is FFS). In successful case it sends a RELOCATION REQUEST message to the target RNS. The RELOCATION REQUEST contains essentially the received UTRAN information field and bearer identifier of each bearer to be established to the new Iu interface.

When the target RNS has received RELOCATION REQUEST message and all active bearers are identified, it should send a RELOCATION PROCEEDING1 message to the CN. This message contains essentially the Binding ID for each Iu leg to be established between UTRAN and CN.

Upon reception of RELOCATION PROCEEDING1 (FFS) the CN should setup Iu legs (and indicate corresponding binding ID to UTRAN). After completion of this, the CN should send a RELOCATION PROCEEDING2 message to the source RNS. The source RNC will then send a RNSAP RELOCATION COMMIT message to the target RNC via the Iur interface as described in RNSAP protocol specification.

Target RNS can, after having received RELOCATION COMMIT from the source RNC, start to act as the serving RNS for the RRC connection in question. After completing this, the target RNS (i.e. the new Serving RNS) sends RELOCATION COMPLETE to CN elements. CN elements will then release all bearers towards the old source RNS.

An example of a corresponding message flow at Iu interface in a successful situation is presented in Figure 1.

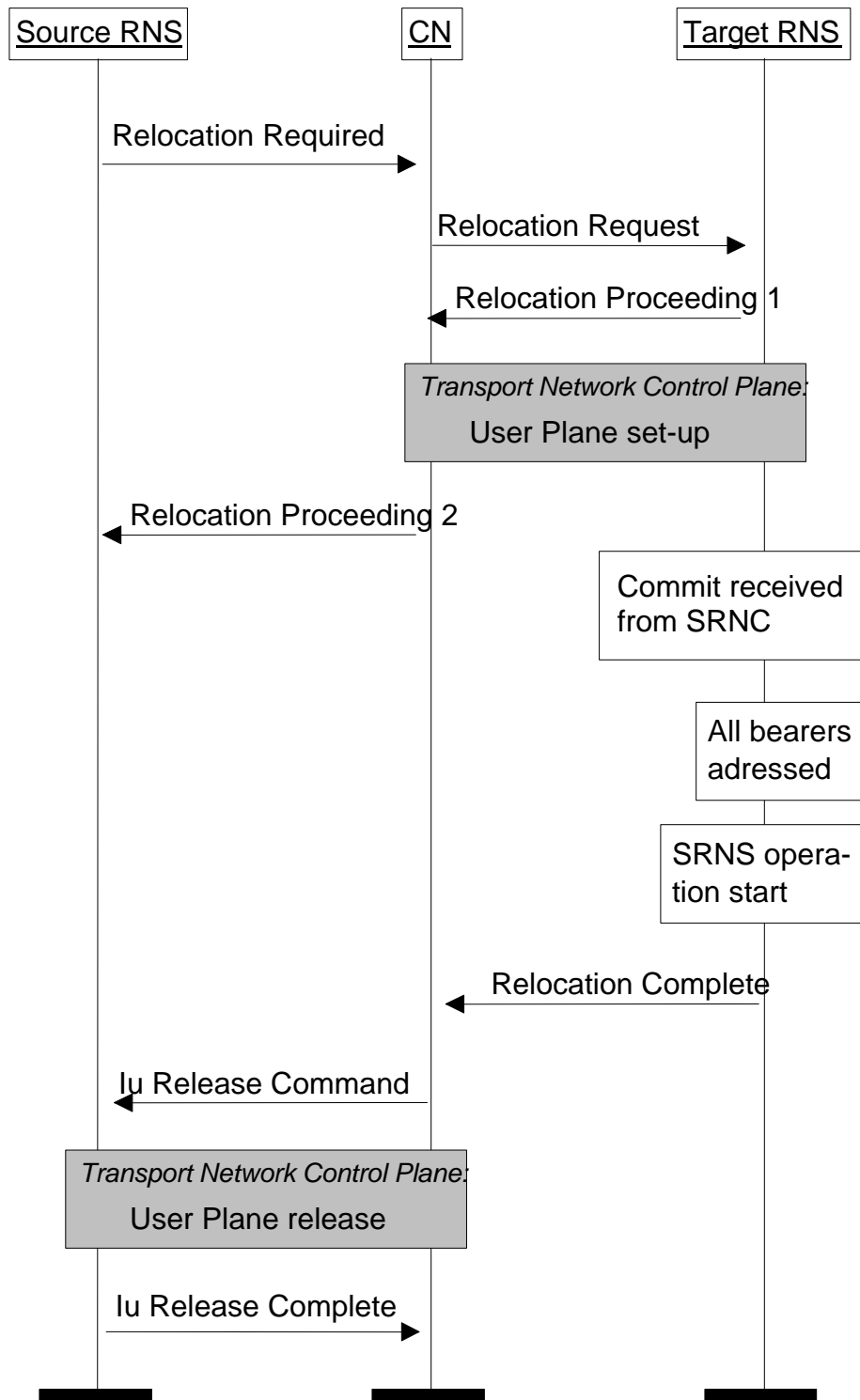

Figure 1. An example RANAP protocol message flow at Iu interface related to relocation of the Serving RNS functionality. A successful case.

Inter RNS hard handover

[Editor's note: The contents of this chapter must be restructured to show the elementary procedures over the Iu interface. Also, it need to be aligned with the corresponding procedures in signalling examples document.]

[Editor's note: It was decided to take the Inter RNS hard handover procedure from TTC/ARIB document as a starting

point, since it is better aligned with signalling examples document.]

Inter RNS hard handover is used to relocate the serving RNS functionality from one RNS to an other and to change the radio resources assigned for the corresponding UE by a hard change. This procedure can be used within one UTRAN if the Iur interface can not (or is not desired to) be used for active set management, between two UTRANs or at UTRAN side in handovers between two Radio Access systems (e.g. UMTS to GSM).

Inter RNS hard handover is carried over Iu interface, namely by the RANAP protocol. The required functionality is described below by introducing an example Iu interface RANAP procedure for the purpose.

All RANAP messages concerned with handover are sent using the connection oriented mode of the SCCP.

Procedure is initiated by the Serving RNC by sending a HANOVER REQUIRED message to active CN nodes. HANOVER REQUIRED message allows a RNC to request that a handover is to be carried out for a particular UE, having signalling connection via the serving RNC. If the CN node can not realise the hard handover a HANOVER FAILURE message is returned.

Chapter 9.2.3.1.23 gives the parameters included in the above message (FFS).

The HANOVER REQUIRED message shall be updated and repeated by the RNC with a periodicity of Txx until:

- A HANOVER COMMAND message is received or;
- A RESET message is received, or;
- The reason for the original HANOVER REQUIRED message disappears e.g. the UE transmission improves, or;
- All communication is lost with the UE, and the transaction is abandoned, or;
- The transaction ends, i.e. signalling connection to the CN node is released.

The CN node sends a HANOVER REQUEST message to the target RNC (selected by the source RNC and indicated in the HANOVER REQUIRED message) from which it requires radio resources. This message contains details of the resource(s) required.

Chapter 9.2.3.1.24 gives the parameters included in the above message (FFS).

On receipt of this message the target RNC shall check availability of radio and terrestrial resources.

If a radio resource is available then this will be reflected back to the CN node in a HANOVER REQUEST ACKNOWLEDGE message. This message is transmitted to the CN node, when the target RNC has received and processed HANOVER REQUEST messages from all active CN nodes.

Chapter 9.2.3.1.25 gives the parameters included in the above message (FFS).

The HANOVER REQUEST ACKNOWLEDGE message sent by the target RNC shall contain the radio interface message HANOVER COMMAND within its "Layer 3 Radio Information" Information Element. This "Layer 3 Radio Information" (which is in fact the RRC-Layer HANOVER COMMAND) is transferred by the CN node to the source RNC using the RANAP message HANOVER COMMAND.

The source RNC then sends to the UE over the radio interface the RRC-Layer HANOVER COMMAND message. Information about the appropriate radio resources and a handover reference number chosen by the target RNC are contained in the HANOVER COMMAND.

Chapter 9.2.3.1.26 gives the parameters included in the above message (FFS).

The target RNC shall then take all necessary action to allow the UE to access the radio resource(s) that the target RNC has chosen.

When the UE accesses the radio resource(s) of the target RNC, the target RNC shall send a HANOVER DETECT message to the active CN nodes.

When the UE is successfully in communication with the target RNC, i.e. the RRC message HANDOVER COMPLETE has been received from the UE, then the target RNC will immediately send a RANAP message HANDOVER COMPLETE to the CN nodes and terminate the procedure.

CN will then release all bearers towards the old serving RNS.

An example of a corresponding message flow at Iu interface in a successful situation is presented in Figure 2.

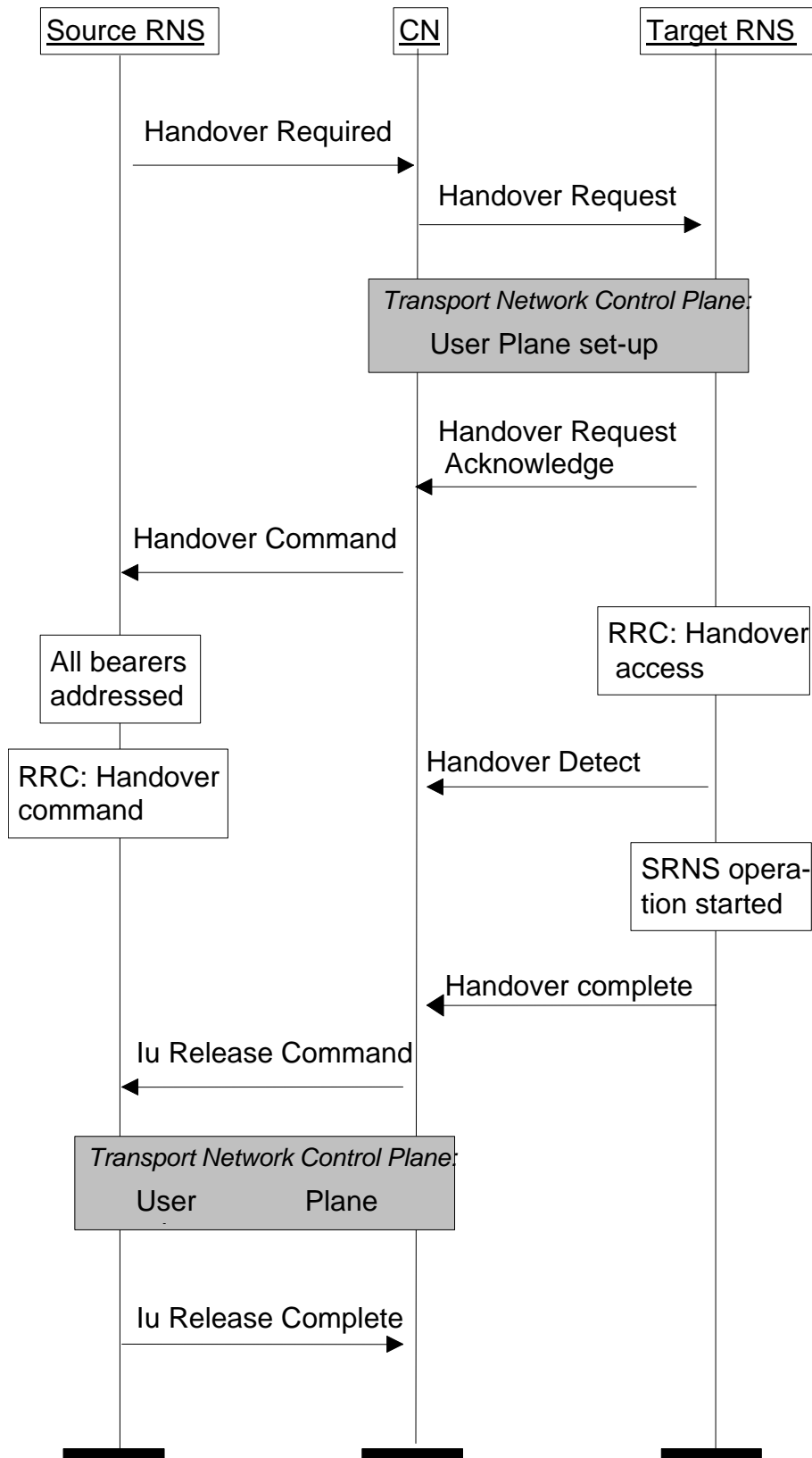

Figure 2. An example RANAP protocol message flow at Iu interface related to Inter RNS Hard Handover. A successful case.

Radio Access Bearer Assignment

[Editor's note: TTC/ARIB has split the RAB Assignment procedure to separate Bearer setup, release and reconfiguration procedures. ETSI is using one procedure handling all of these. TTC/ARIB Bearer setup, release and

reconfiguration procedures are presented after ETSI RAB Assignment procedure for comparison. A new study item is opened.

Study item Iu-5: The use of a single RAB assignment procedure versus separate bearer setup, release and reconfiguration procedures.

[Editor's note: ETSI RAB Assignment procedure is presented first.]

This procedure is triggered from the CN side and is used to modifying the list of bearers established between the requesting CN element and a given MS for which a RRC connection exists with the requesting CN element prior the running of the procedure.

The procedure is started by the CN sending a RANAP RADIO ACCESS BEARER ASSIGNMENT REQUEST message. Such a message contains the information needed for the UTRAN to decide the new bearer configuration to build. This comprises :

- The list of the bearers to establish if possible, with their description and a identity;
- Bearer linking, building group of bearers which must be either all established, or all rejected ;
- The list of the identities of the bearers to keep if possible, with possibly a description when it is changed ;
- The list of the identities of the bearers to release ;

Each list may be empty. The bearers are only those related to RRC connection, i.e., used between the concerned MS and the requesting CN element. This excludes bearers set with other MS or with other CN elements.

For each bearer to establish, the following information is provided :

- An identity (bearer identity), used for eventual reference ;
- The characteristics of the MS-CN bearer, including such aspects as data rates, transmission quality of service, ... Some of them may include negotiable values.
- Priority level and pre-emption indication ;
- Possibly a bit string to be passed to the upper layer on the UE side together with the bearer establishment indication.
- Binding Id used for associating the bearer identity and the corresponding User plane. The details of using the Binding Id are FFS.

For each bearer to keep if possible, none, part or all of the following information may be provided in addition to the bearer identity :

- The characteristics of the MS-CN bearer, including such aspects as data rates, transmission quality of service, ...
- Priority level and pre-emption indication.

For each bearer to be released, only the bearer identity is provided. If a radio channel release is required because of a UTRAN generated reason (e.g. "O and M intervention", "equipment failure", or if transmission from the UE is lost) then, the RNC shall generate a RADIO ACCESS BEARER RELEASE REQUEST message towards the CN. This message shall include a Cause Information Element, indicating the reason for the failure. On receipt of a RADIO ACCESS BEARER RELEASE REQUEST the CN shall initiate the release, as defined above, by sending a RANAP RADIO ACCESS BEARER ASSIGNMENT REQUEST message. On receipt of this message the UTRAN shall, if the resources are not already internally released, release the resources in the normal way. The procedure is always terminated with a RANAP RADIO ACCESS BEARER ASSIGNMENT COMPLETE to the CN. This procedure handles both pre-configured and by-demand connections. The signalling flow for this procedure has been illustrated in Figure 3.

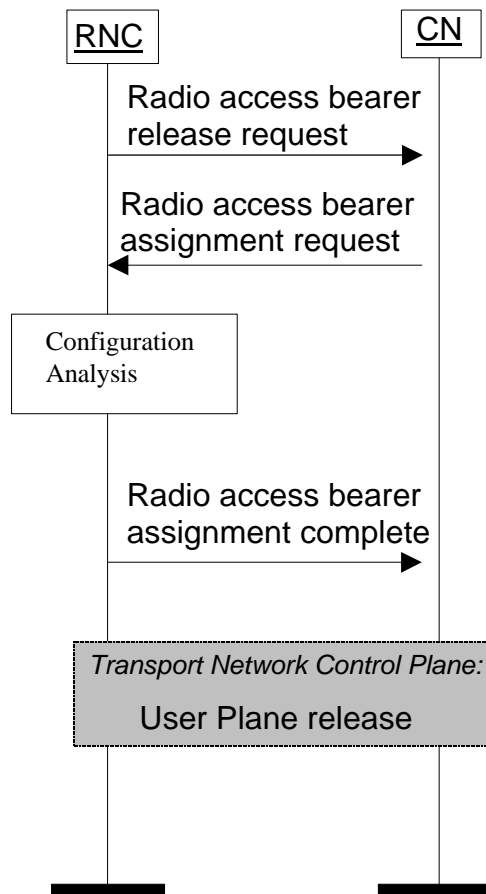

Figure 3. Radio Access Bearer Assignment procedure, UTRAN generated release.

On the basis of the information provided, of the MS capabilities, of the information pertaining to all bearers already established with the MS (in particular the priority level and pre-emption indication), the UTRAN decides on the new MS-UTRAN bearer configuration, and starts the AN-MS procedures to set this configuration, and, when applicable, the procedures to establish and release local AN-CN bearers. The algorithm applied to reach the decision is outside the scope of this protocol specification.

The UTRAN shall report to the different CN elements the changes of configuration when effective, or when put in queue. This can be done in one or several messages, depending on the case, and on UTRAN choices.

A RANAP RADIO ACCESS BEARER ASSIGNMENT COMPLETE message is sent to the requesting CN element when the whole request has been dealt with effectively. Such a message contains part or whole of the following information :

- The list of the bearer identities for the bearer successfully established or modified, if not already indicated ; with each bearer identity is provided the negotiable parameters as chosen by the UTRAN and the Binding Id used for associating the bearer identity and the corresponding User plane. The details of using the Binding Id are FFS.
- The list of the bearers which have been released, with for each a cause, if not already indicated.
- Localisation data, when the AN got more information on where is the MS while running the procedure.

The sending and the reception of this message ends the procedure between the UTRAN and the requesting CN element.

When at least one requested bearer has not been established, a RANAP RADIO ACCESS BEARER ASSIGNMENT FAILURE message is sent instead.

Such a message contains part or whole of the following information :

- The list of the bearer identities for the bearer successfully established or modified, if not already indicated ; with each bearer identity is provided the negotiable parameters as chosen by the UTRAN.
- The list of the bearers which has not been, and will not be, established, with for each a cause ;
- The list of the bearers which have been released, with for each a cause, if not already indicated.
- Localisation data, when the AN got more information on where is the MS while running the procedure.

A RANAP QUEUING INDICATION message can be sent to the requesting CN element prior to the RANAP RADIO ACCESS BEARER ASSIGNMENT COMPLETE or RANAP RADIO ACCESS BEARER ASSIGNMENT FAILURE message to indicate that only part of the request has been fulfilled, and that the rest has been in queue. This message contains the same kind of information as the RANAP RADIO ACCESS BEARER ASSIGNMENT COMPLETE message.

A RANAP BEARER CLEARED INDICATION message shall be sent to a CN element to indicate a bearer, or bearers, previously established between this element and the MS and which have been released that due to pre-emption.

The signalling flow for the Radio access bearer assignment procedure has been illustrated in Figure 4.

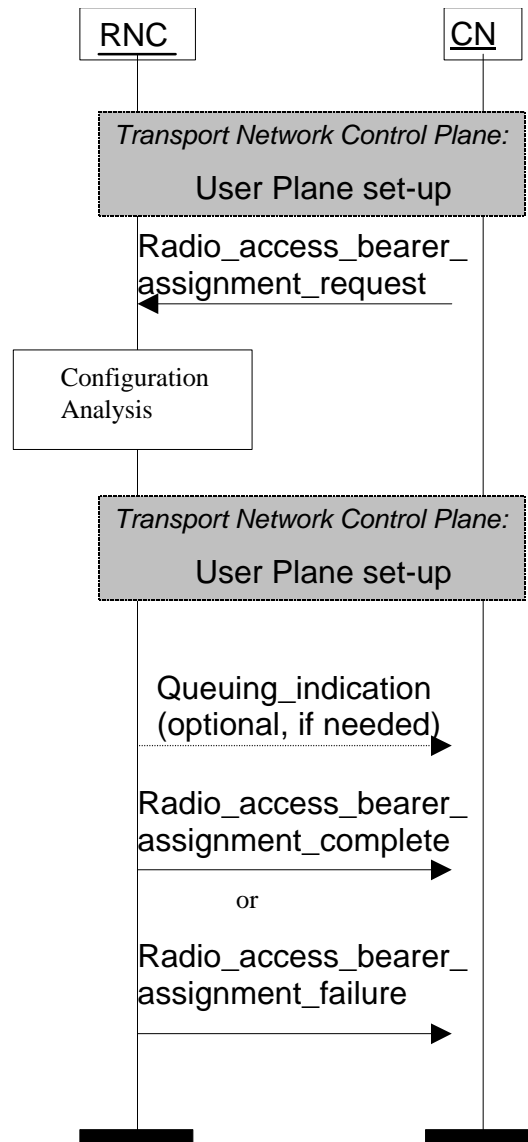

Figure 4. Radio Access Bearer Assignment procedure.

[Editor's note: Radio Access Bearer setup, release and reconfiguration procedures of TTC/ARIB are included here for comparison. (Study item 5).]

8.3 Radio Acces Bearer Setup

This procedure is triggered from the CN side and is used to establish a new bearer between the requesting CN element and a given UE

The procedure is started by the CN sending a RADIO ACCESS BEARER SETUP message. Such a message contains the information needed for the UTRAN to decide the new bearer configuration to build.

For the radio access bearer to establish, the following information is provided:

- An identity (bearer identity), used for eventual reference ;
- The characteristics of the UE-CN bearer, including such aspects as data rates, transmission quality of service, ... Some of them may include negotiable values.
- Binding Id used for associating the bearer identity and the corresponding User plane. The details of using the Binding Id are FFS.

A RADIO ACCESS BEARER SETUP RESPONSE message is sent to the requesting CN element when the whole request has been dealt with effectively.

The sending and the reception of a RADIO ACCESS BEARER SETUP RESPONSE message end the procedure between the UTRAN and the requesting CN element.

When the requested bearer has not been established, a RADIO ACCESS BEARER SETUP FAILURE message is sent instead.

The signalling flow for the Radio Access Bearer setup procedure has been illustrated in Figure 4.

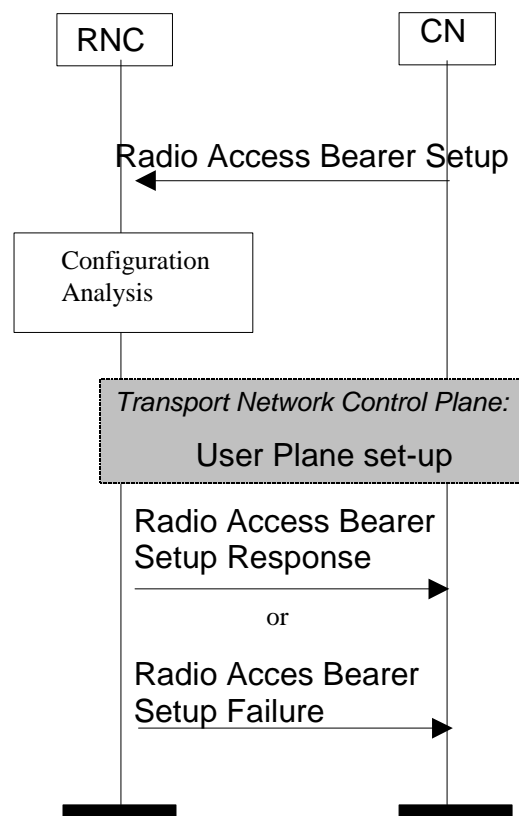

Figure 4. Radio Access Bearer Setup procedure.

8.4 Radio Access Bearer Release (FFS, Study item 5)

8.4.1 Release due to Transaction Completion

This procedure used for the release of assigned radio resources at the end of a transaction

Release negotiation will take place directly between the UE and CN using transparent messages via the DIRECT TRANSFER in the RANAP. The CN then send a RADIO ACCESS BEARER RELEASE, indicating that the radio resource(s) should be released. After the RADIO ACCESS BEARER RELEASE has been sent, the CN shall not send further RANAP connection oriented messages on this particular connection, except RADIO ACCESS BEARER RELEASE.

When the RNC receives the RADIO ACCESS BEARER RELEASE, it marks the related resources as idle and return RADIO ACCESS BEARER RELEASE RESPONSE.(the RNC need not wait for the radio channel release to be completed.)

On receipt of RADIO ACCESS BEARER RELEASE RESPONSE, the CN releases the related resources.

The signaling flow for this procedure has been illustrated in Figure 5.

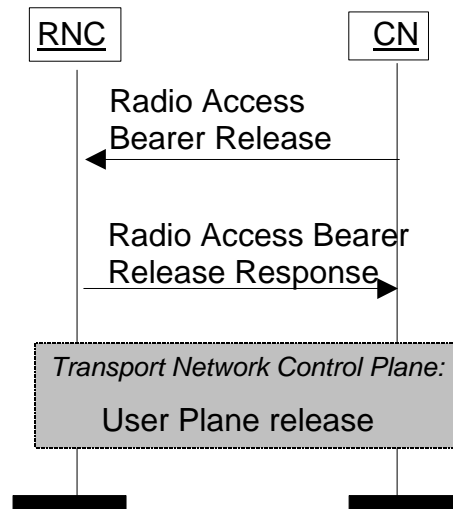

Figure 5. Radio Access Bearer Release procedure

8.4.2 Release due to UTRAN Generated Reason

If a radio channel release is required because of a UTRAN generated reason (e.g. “O and M intervention”, “equipment failure”, or if transmission from the UE is lost) then, the RNC shall generate a RADIO ACCESS BEARER RELEASE REQUEST message towards the CN. This message shall include a Cause Information Element, indicating the reason for the failure. On receipt of a RADIO ACCESS BEARER RELEASE REQUEST the CN shall initiate the “Radio Access Bearer Release due to Transaction Completion Procedure (describes in chapter .xx)” or “Iu Release Procedure (describes in chapter .xx)”, as defined above, by sending a RADIO ACCESS BEARER RELEASE message or indicate release of the Iu Interface by sending a IU RELEASE message.

On receipt of a RADIO ACCESS BEARER RELEASE message or IU RELEASE message the UTRAN shall, if the resources are not already internally released, release the resources in the normal way. The procedure is always terminated with a RADIO ACCESS BEARER RELEASE RESPONSE or IU RELEASE RESPONSE to the CN.

The signaling flow for this procedure has been illustrated in Figure 6.

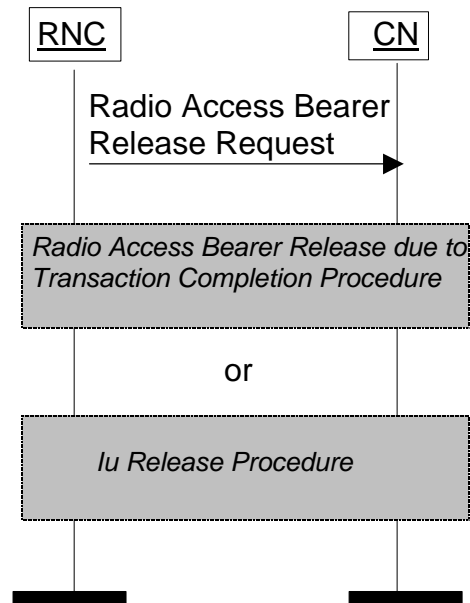

Figure 6. Radio Access Bearer Release procedure, UTRAN generated release

8.5 Radio Access Bearer Reconfiguration (FFS, Study item 5)

This procedure is triggered from the CN and is used to modify the radio access bearer characteristic e.g. data rate, quality of service.

The CN sends a RADIO ACCESS BEARER RECONFIGURATION message to request modification of the bearer. This message contents:

- An identity (bearer identity)
- The characteristics of the UE-CN bearer, including such aspects as data rates, transmission quality of service.

When the UTRAN received this message, it analysis the related bearer and start to reconfiguration of bearer between the UE and the UTRAN. If the procedure is confirmed, the UTRAN send a RADIO ACCESS BEARER RECONFIGURATION RESPONSE message. If the procedure is failure, the UTRAN send a RADIO ACCESS BEARER RECONFIGURATION FAILURE message.

The signalling flow for the Radio Access Bearer Reconfiguration procedure has been illustrated in Figure 7.

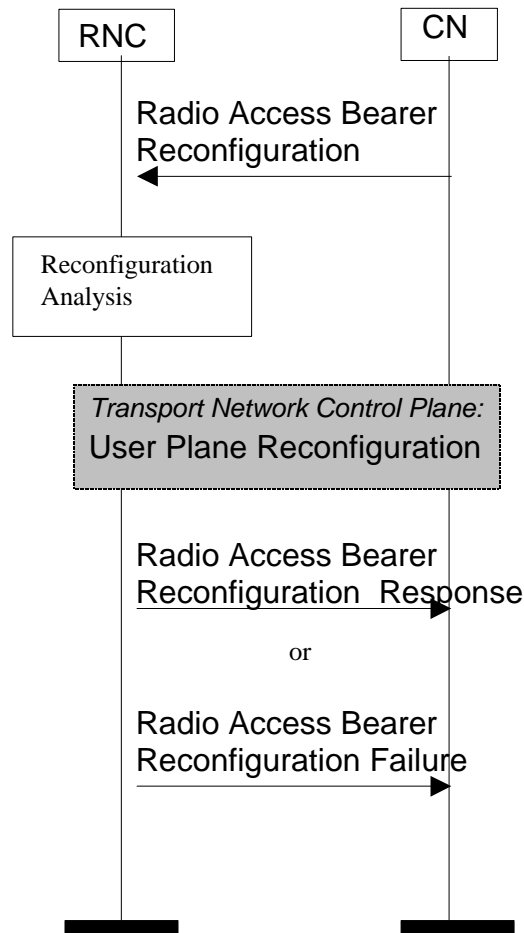

Figure 7. Radio Access Bearer Reconfiguration procedure.

[Editor's note: Description of TTC/ARIB's setup, release and reconfiguration procedures ends, return back to common text.]

Iu Release

[Editor's note: TTC/ARIB has a similar procedure called Signalling channel release. Since this procedure is FFS in ETSI, the TTC/ARIB procedure is not included. TTC/ARIB has agreed to adopt the ETSI names for the messages of this procedure.]

The CN uses the IU RELEASE COMMAND message to release all resources in the SRNS related to this Iu connection.

The Iu Release procedure can be initiated for the following reasons:

- Completion of transaction between UE and CN
- UTRAN generated reasons
- Completion of successful handover or SRNS relocation

The Iu Release procedure messages i.e. Iu RELEASE REQUEST, Iu RELEASE COMMAND, Iu RELEASE COMPLETE are sent as connection oriented messages over the appropriate Iu connection.

Iu Release due to completion of transaction between UE and CN

The release of assigned radio bearers at the end of a transaction will take place as follows:

Release negotiation will take place directly between the UE and CN using transparent messages via UTRAN. The CN will then send an Iu RELEASE COMMAND, indicating that the radio bearers(s) and Iu resources should be released. After the Iu RELEASE COMMAND has been sent, the CN shall not send further RANAP connection oriented messages on this particular connection, except Iu RELEASE COMMAND.

The Iu RELEASE COMMAND message shall include a Cause Information Element, indicating the reason for the release.

The RNS at the opposite access point shall initiate the release of the user plane resources allocated to the connection, if any.

When the RNS receives the Iu RELEASE COMMAND:

- 1) The clearing on the radio interface initiated
- 2) The RNS returns an Iu RELEASE COMPLETE message to the CN originating the Iu RELEASE COMMAND message and takes action to return any assigned user plane resources to idle. (The RNC need not wait for the radio channel release to be completed before returning the Iu RELEASE COMPLETE message.)

The signalling flow for Iu Release procedure due to completion of transaction between UE and CN is shown in Figure 5:

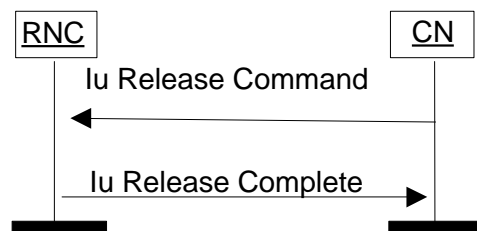

Figure 5. Iu Release: Completion of transaction between UE and CN.

Iu Release due to UTRAN generated reasons

If the release of the radio bearers assigned to a particular UE is required because of a UTRAN generated reason (e.g. "O and M intervention", "equipment failure") then, the RNS controlling the Iu connection(s) of that particular UE shall generate an Iu RELEASE REQUEST message towards the CN. If it exists two Iu connections for that particular UE, then an Iu RELEASE REQUEST message shall be sent to CN domain.

If the contact with the UE is lost then an Iu RELEASE REQUEST message shall be sent to the CN node(s) having an Iu connection with the RNS for that particular UE.

The Iu RELEASE REQUEST message shall include a Cause Information Element, indicating the reason for the release.

On receipt of an Iu RELEASE REQUEST message, the CN node shall initiate the release, as defined above, by sending an Iu RELEASE COMMAND message. On receipt of this message the RNS shall, if the resources are not already released, release the resources in the normal way. The procedure is always terminated with an Iu RELEASE COMPLETE to the CN originating the Iu RELEASE COMMAND message.

The signalling flow for Iu Release procedure due to UTRAN generated reasons is shown in Figure 6:

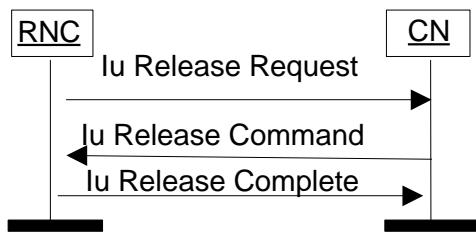

Figure 6. Iu Release: UTRAN generated reasons.

Iu Release due successful handover or SRNS relocation

In the case of a handover or SRNS relocation being successfully completed, then the resources at the old RNS are released by the CN using the Iu release sequence. The cause value used by the CN in the Iu RELEASE COMMAND message shall be set to the appropriate value: “handover successful” or “SRNS relocation successful”.

When the RNS detects one of these cause values in an Iu RELEASE COMMAND message, then it shall return an Iu RELEASE COMPLETE message to the appropriate CN and take action to return to idle any resources attached to that particular Iu connection.

In the case where there is a second Iu connection for that particular UE, then the RNC shall wait the second Iu RELEASE COMMAND message before returning the remaining resources assigned to that UE to idle. Once the second Iu RELEASE COMMAND is received, the procedure completes normally.

The signalling flow for Iu Release procedure due to completion of transaction between UE and CN is shown in Figure 7:

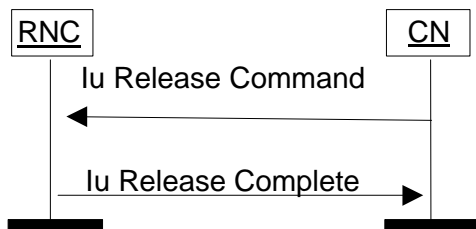

Figure 7. Iu Release: successful handover or SRNS relocation.

Overload Control

[Editor's note: TTC/ARIB does not have Overload control procedure. The ETSI procedure is used as a base.]

These procedures are defined to give some degree of flow control. At the UTRAN processor overload and overload in the capability to send signalling messages to the UE are catered for, and at the CN processor overload is catered for.

Philosophy

The philosophy used is to stem the traffic at source with known effect on the service. The algorithm used is:

- On receipt of the first OVERLOAD message or signaling point congested information, the traffic is reduced by one step. At the same time, timers T(igOC)(T(igOR)) and T(inTC)(T(inTR)) are started. During T(igOC)(T(igOR)) all received overload messages or signaling point congested information are ignored in order not to reduce the traffic too rapidly. Reception of an OVERLOAD message or signaling point congested information after expiry of T(igOC)(T(igOR)) but still during T(inTC)(T(inTR)) , will decrease the traffic load by one more step, and restart T(igOC)(T(igOR)) and T(inTC)(T(inTR)).

- This step by step reduction of traffic is continued until maximum reduction is obtained by arriving at the last step. If $T(\text{inTC})(T(\text{inTR}))$ expires (i.e. no OVERLOAD message or signaling point congested information is received during $T(\text{inTC})(T(\text{inTR}))$) the traffic will be increased by one step and $T(\text{inTC})(T(\text{inTR}))$ will be started, unless full load has been resumed.

NOTE: Timers $T(\text{igOC})$ and $T(\text{inTC})$ are running in the CN whilst Timers $T(\text{igOR})$ and $T(\text{inTR})$ are running in the UTRAN.

- The number of steps and the method of reducing the load is considered to be an implementation specific function.

There may be other traffic control mechanisms from O and M activities occurring simultaneously.

Overload at the CN

The CN can indicate to the RNC that it is in a congested state by sending an OVERLOAD message. This is sent as a connectionless global message.

At the UTRAN receipt of this message causes the reduction of traffic to the CN node sending the message using the method described in subclause 9.2.2.4.1.

The signalling flow for Overload at the CN is shown in Figure 8.



Figure 8. Overload at the CN.

Overload at the UTRAN

If the UTRAN is not capable to send signalling messages to the UE due to overloaded resources then the UTRAN sends an OVERLOAD message to the CN with the appropriate cause (Cause value: "overload in the capability to send

If the UTRAN processing is overloaded then the RNC sends an OVERLOAD message with the Cause value: "processor

The CN originated traffic is reduced in accordance with the method described in subclause 9.2.2.4.1.

The signalling flow for Overload at the UTRAN is shown in Figure 9.



Figure 9. Overload at the UTRAN.

Message throughput congestion

If the lower layers of the protocol for Radio Network Control Plane Signaling Bearer become congested then it is assumed that the MTP congestion indication will take place and the source of the traffic will receive primitives from the transport protocols resulting in it reducing the generated load.

A suitable method to achieve this reduction could be based on that given in subclause 9.2.2.4.1.

Reset

[Editor's note: This procedure from ETSI is aligned with the TTC/ARIB procedure and is used as a base.]

The purpose of the reset procedure is to initialise the UTRAN and CN in the event of a failure. The procedure is a global procedure applying to a whole RNC (instead of a particular UE), and therefore all messages relating to the reset procedure are sent as global messages using the connectionless mode of the SCCP.

If only a limited part of the CN or UTRAN has suffered a failure then Radio Access Bearer Assignment Request procedures (indicating bearer release) can be used to clear only the affected Radio Access Bearers.

Reset at the UTRAN

In the event of a failure at the UTRAN which has resulted in the loss of transaction reference information, a RESET message is sent to the CN. This message is used by the CN to release affected Radio Access Bearers and erase all affected references.

After a guard period of T(RatR) seconds a RESET ACKNOWLEDGE message is returned to the UTRAN indicating that all references have been cleared.

The signalling flow for Reset at the UTRAN is shown in Figure 10.

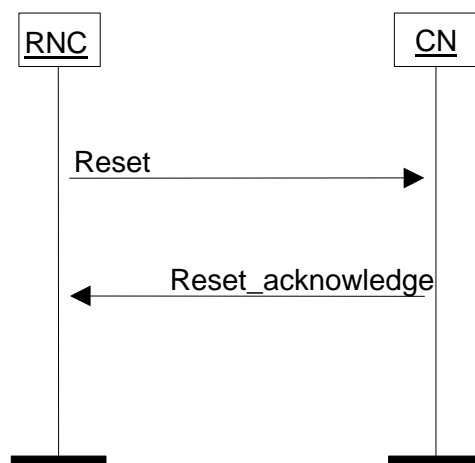
**Figure 10. Reset at the UTRAN.**

Reset at the CN

In the event of a failure at the CN which has resulted in the loss of transaction reference information, a RESET message is sent to the RNC. This message is used by the UTRAN to release affected Radio Access Bearers and erase all affected references.

After a guard period of T(RatC) seconds a RESET ACKNOWLEDGE message is returned to the CN, indicating that all Ues which were involved in a call are no longer transmitting and that all references at the UTRAN have been cleared.

Figure 11 shows the signalling flow for Reset at the CN.

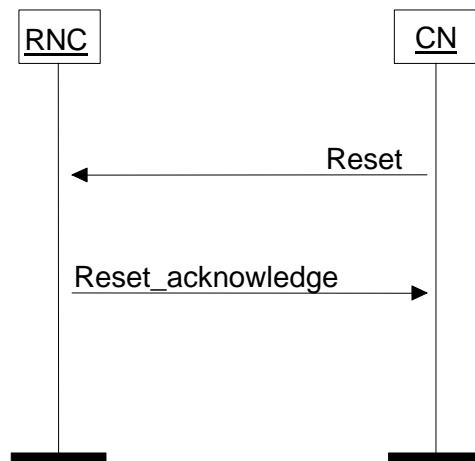

Figure 11. Reset at the CN.

Abnormal Conditions

Abnormal Condition at the UTRAN

If the RNC sends a RESET message to the CN and receives no RESET ACKNOWLEDGE message within a period $T(\text{RafC})$ then it shall repeat the entire reset procedure. The sending of the RESET message is repeated a maximum of “n” times where n is an operator matter. After the n-th unsuccessful repetition the procedure is stopped and the maintenance system is informed.

Abnormal Condition at the CN

If the CN sends a RESET message to the RNC and receives no RESET ACKNOWLEDGE message within a period $T(\text{RafR})$ then it shall repeat the entire reset procedure. The sending of the RESET message is repeated a maximum of “n” times where n is an operator matter. After the n-th unsuccessful repetition the procedure is stopped and the maintenance system is informed.

Crossing of Reset messages

Actions for the case, when the entity, which has sent a RANAP RESET message and is waiting for a RANAP RESET ACKNOWLEDGE message, but receives a RANAP RESET message are FFS.

Common Id

[Editor's note: ETSI procedure is used as a base.]

This procedure is needed, if the MM concept will require the UTRAN to send a page message on the existing RRC connection.

The purpose of the RANAP Common Id procedure is to allow the RNC to create a reference between the IMSI of a user and the RRC connection of that user. This is achieved by sending the IMSI of a verified user from the CN to the RNC. The RNC is then able to check whether there is already signaling bearer to the UE when a CN starts connection establishment by sending Paging message. The signaling bearer can be already used by an other CN, and if this is the case, the RNC uses it to send the Paging message to the MS.

The CN sends a COMMON ID message after it has ensured the identity of UE. The message contains the IMSI of the user. The RNC associates the permanent identity to the RRC Connection of that user and saves it for the duration of the RRC connection. The signalling flow Common Id procedure is shown in Figure 12.



Figure 12. Common Id procedure.

Paging

[Editor's note: TTC/ARIB is using Initial UE message to send the PAGING RESPONSE received from the radio interface to the CN. In ETSI this is FFS. It was decided to use an elementary procedure, which shows only the PAGING message.]

PAGING messages for all UEs shall be sent via the RANAP as a connectionless message. These will include some information to allow derivation of the paging population number, the IMSI of the user to be used as the Common Id of the user in the RNC, the Id of the User to be used in the paging channel (e.g. TMSI); they may also include information on the subsequent transaction related to the paging. A corresponding radio interface paging message transmitted over the radio interface at the appropriate time. The issue of storing the RANAP PAGING message for future paging repetition is FFS.

It should be noted that each RANAP PAGING message on the CN-UTRAN interface relates to only one UE and therefore the UTRAN has to pack the pages into the relevant radio interface paging message.

A single RANAP PAGING message across the CN to UTRAN interface contains information on the area in which the page shall be broadcast. This is indicated with UE location parameter (content FFS, e.g. LA or RA).

The signalling flow of the paging procedure is illustrated in Figure 13.



Figure 13. Paging procedure.

Trace Invocation

[Editor's note: TTC/ARIB does not have Trace Invocation procedure. The ETSI procedure is used as a base.]

The purpose of the trace invocation procedure is to inform the receiving entity that it should begin producing a trace record on this particular transaction.

The trace is invoked by the CN sending a RANAP CN INVOKE TRACE message to the UTRAN.

The events and parameters to be recorded are indicated in the "Trace type" information element.

The element "OMCId", if present, indicates the OMC to which the record is destined.

The CN may allocate and include an "CN transaction reference" (typically a call reference) into the RANAP CN INVOKE TRACE message. The transaction reference is contained in the information element "TransactionId".

The message includes a trace reference which is allocated by the entity which triggered the trace.

The element “TriggerId”, if present, indicates the entity which triggered the trace.

The trace reference, triggerId and transactionId Information Elements are used to tag the trace record to allow simpler construction of the total record by the entity which combines trace records.

The messages are not acknowledged and are sent as a connection oriented message on the connection on which a trace is required.

The signalling flow of the Trace invocation procedure is shown in Figure 14.

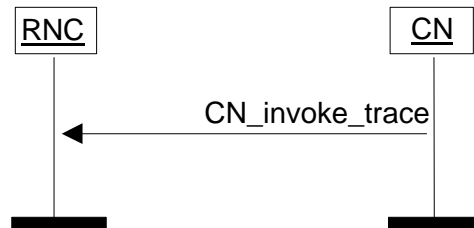

Figure 14. Trace Invocation procedure.

Cipher Mode Control

[Editor's note: Study item Iu/6 has been solved. It has been agreed to that the UTRAN would select the algorithm from a CN provided list, using the UE capability information.]

Successful operation

The cipher mode control procedure allows the CN to pass cipher mode information to the UTRAN to select and load the user data and signaling encryption device with the appropriate key.

This is achieved by sending the UTRAN a RANAP CIPHER MODE COMMAND message. Receipt of the message at the UTRAN will cause the generation of a radio interface CIPHERING MODE COMMAND message and, if applicable, invoke the encryption device and start stream ciphering.

If within the RANAP CIPHER MODE COMMAND, the signaling element “Cipher response mode” is present and indicates “IMEI must be included by the Mobile Station”, then the UTRAN shall request in the radio interface message CIPHERING MODE COMMAND the Mobile Station to include its IMEI in the radio interface CIPHERING MODE COMPLETE message.

In the RANAP CIPHER MODE COMMAND the CN specifies which of the ciphering algorithms may be used by the UTRAN. The UTRAN then selects internally an appropriate algorithm, taking into account the UE ciphering capabilities. The UTRAN can deduce from the UE capability information of the supported algorithms. The RANAP CIPHER MODE COMPLETE message returned to the CN indicates the chosen ciphering algorithm. The set of permitted ciphering algorithms specified in the RANAP CIPHER MODE COMMAND shall remain applicable for subsequent Assignments and Intra-UTRAN Handovers.

The RANAP CIPHER MODE COMMAND and RANAP CIPHER MODE COMPLETE messages are sent as connection oriented messages via the appropriate SCCP connection.

Receipt of the radio interface CIPHERING MODE COMPLETE message (or other correctly deciphered layer 2 frame) from the radio interface is used internally within the UTRAN to achieve radio interface ciphering synchronisation. When the UTRAN receives the radio interface CIPHERING MODE COMPLETE from the UE a RANAP CIPHER MODE COMPLETE message is returned to the CN.

The handling of ciphering keys from two CN entities is FFS.

The signalling flow of the successful Cipher mode control procedure is shown in Figure 15.

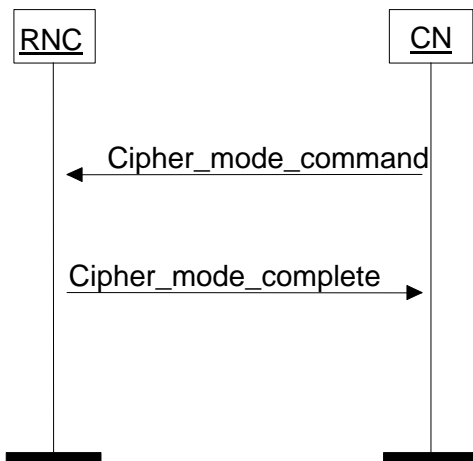

Figure 15. Cipher Mode Control procedure, successful case.

Abnormal conditions

If the UTRAN or the UE is unable to support the ciphering algorithm specified in the RANAP CIPHER MODE COMMAND message then it shall return a RANAP CIPHER MODE REJECT message with Cause value “Ciphering algorithm not supported”. A RANAP CIPHER MODE REJECT message shall also be returned if the CN requests a change of ciphering algorithm when ciphering is already active.

The signalling flow of the Cipher mode control procedure in abnormal conditions is shown in Figure 16.

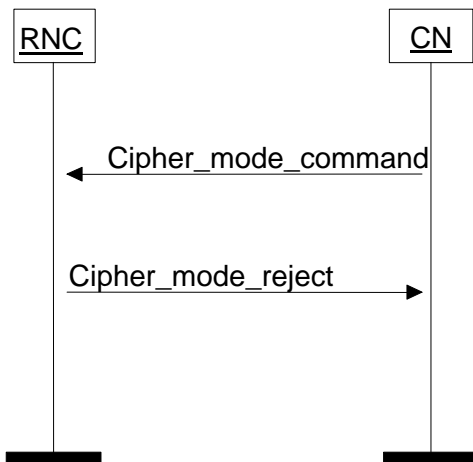

Figure 16. Cipher Mode Control procedure, unsuccessful case.

CN Information Broadcast

[Editor's note: TTC/ARIB does not have CN Information broadcast procedure. The ETSI procedure is used as a base.]

A functionality of the (UT)RAN is to broadcast repetitively to all users [in idle mode] system information as provided by the core network. A core network element sets or modifies the CN system information by sending a RANAP CN INFORMATION BROADCAST REQUEST message which indicates:

- The information pieces to be broadcast, as a number of bit strings. The internal structure of these bit strings is not known or analysed by the RAN, and is specified as part of the CN-MS protocols.
- With each bit string, a geographical area where to broadcast it.

- With each bit string, some categorisation parameters to be used by the RAN to determine how to schedule the repetition cycle.

If the UTRAN can broadcast the information as requested, a RANAP CN INFORMATION BROADCAST CONFIRM message is returned to the CN.

If the UTRAN can not broadcast the information as requested, a RANAP CN INFORMATION BROADCAST REJECT message is returned to the CN.

Each information piece is broadcast in the intersection between the indicated geographical area and the area under control by the receiving RNC. It is broadcast until explicitly changed or a reset occurs. A CN element will run this procedure typically after each reset, and whenever the information needs to be changed.

Between a reset and the first reception of this message, what is broadcast is FFS. However, great care shall be taken to ensure that UE's do not reselect another PLMN and cause e.g. a surge of location updating on that other PLMN.

Direct Transfer

[Editor's note: This procedure is otherwise aligned with TTC/ARIB except for message names. The message name from TTC/ARIB document will be adopted, thus 'Direct Transfer Request' will be changed to 'Direct Transfer' .]

The Direct Transfer procedure is used to carry UE – CN signalling messages over the Iu Interface. The UE – CN signalling messages are not interpreted by the UTRAN, and their content (e.g. MM or CC message) is outside the scope of this specification. The UE – CN signalling messages are transported as a parameter in the Direct Transfer messages.

When the CN has message that has to be sent to the UE (e.g. a CC or MM message) it will send DIRECT TRANSFER to the RNC including the CN to UE message as a parameter. The signalling flow for the CN originated Direct transfer procedure is shown in Figure 17.

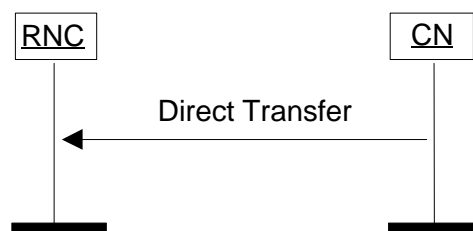

Figure 17. Direct Transfer, CN originated.

When the RNC has received a message from the UE that has to be sent to the CN without interpretation (e.g. a CC or MM message in response to the previously sent CC or MM message from the CN) it will send DIRECT TRANSFER to the CN and including the UE to CN message as a parameter. The signalling flow for the UTRAN originated Direct transfer procedure is shown in Figure 18.



Figure 18. Direct Transfer, RNC originated.

Initial UE Message

[Editor's note: ETSI doesn't have Initial UE Message procedure. TTC/ARIB procedure will be used as a base.

However, TTC/ARIB agree to change the message name in their procedure to 'Initial UE Message'.]

When the Iu signaling connection establishment is performed by the RNC, the radio interface initial layer 3 message received from the UE is proceeded.

The RNC shall analyze the protocol discriminator of the message and if entire radio interface initial layer 3 message (e.g. CM SERVICE REQUEST, LOCATION UPDATE REQUEST, PAGING RESPONSE, IMUI DETACH) is also passed to the CN, using an INITIAL UE MESSAGE. The RNC does not analyze the contents of the initial layer 3 message, it may be added the other information (e.g. chosen channel and cell Identifier)..

The signalling flow for Initial UE Message procedure is shown in Figure 19.

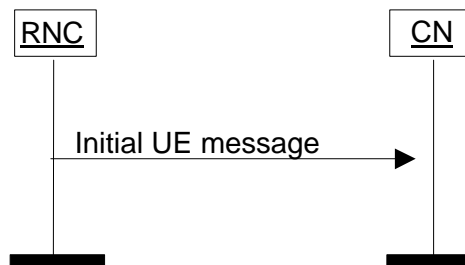

Figure 19. Initial UE Message procedure.

Elements for RANAP communication

Message functional definition and content

[Editor's note: ETSI has not yet discussed the parameters of RANAP messages. The text from the TTC/ARIB document will be used as a starting point, but the contents is not agreed and is FFS. In the cases when the messages are the same, TTC/ARIB agree to adopt the ETSI name for the message.]

For each message there is, a table listing the signaling elements in their order of appearance in the transmitted message.

All the RANAP messages are listed in the following table:

Message name	Reference
RADIO ACCESS BEARER SETUP	
RADIO ACCESS BEARER SETUP RESPONSE	
RADIO ACCESS BAERER SETUP FAILURE	
RADIO ACCESS BEARER RECONFIGURATION	
RADIO ACCESS BEARER RECONFIGURATION RESPONSE	
RADIO ACCESS BEARER RECONFIGURATION FAILURE	
RADIO ACCESS BEARER RELEASE	
RADIO ACCESS BEARER RELEASE RESPONSE	
RADIO ACCESS BEARER RELEASE REOUEST	
COMMON ID	
DIRECT TRANSFER	
INITIAL UE MESSAGE	
CIPHER MODE COMMAND	
CIPHER MODE COMPLETE	
CIPHER MODE REJECT	
PAGING	
IU RELEASE COMMAND	
IU RELEASE COMPLETE	
RELOCATION REQUIRED	
RELOCATION REOUEST	
RELOCATION COMPLETE	

RELOCATION FAILURE (FFS)	
HANDOVER REQUIRED	
HANDOVER REQUEST	
HANDOVER REQUEST ACKNOWLEDGE	
HANDOVER COMMAND	
HANDOVER DETECT	
HANDOVER COMPLETE	
HANDOVER FAILURE	
RESET	
RESET ACKNOWLEDGE	
CONFUSION	

Table 1. List of RANAP messages.

Message Contents

RADIO ACCESS BEARER SETUP (FFS)

The RADIO ACCESS BEARER SETUP message is sent from the CN to the RNC via the relevant SCCP connection in order to request the RNC to assign radio resources, the attributes of which are defined within the message.

INFORMATION ELEMENT	REFERENCE	DIRECTION	TYPE	LEN
Message Identifier		CN-RNC	M	
Length		CN-RNC	M	
Message Compatibility Information		CN-RNC	M	
Bearer ID.		CN-RNC	M (1)	
User Information Rate		CN-RNC	M	
Information Transfer Capability		CN-RNC	M	
ATM address		CN-RNC	M (2)	
ATM Binding ID		CN-RNC	M	
Group Call Reference		CN-RNC	O (3)	
Talker Flag		CN-RNC	O (4)	

- 1 This element should be used instead of Call Id, however if Bearer Id has not been supported, it might be used Call Id.
- 2 This element should include the AAL2 address or ATM address.
- 3 This may be included by the CN for either a talking or listening subscriber in a group call.
- 4 This element is included for group calls, when this is included it indicates that the mobile is a talker in the call else the mobile is a listener.

RADIO ACCESS BEARER SETUP RESPONSE (FFS)

The RADIO ACCESS BEARER SETUP RESPONSE message is sent from the RNC to the CN and that the requested Radio Access Bearer has been completed correctly.

The message is sent via the SCCP connection associated with the dedicated resource(s).

INFORMATION ELEMENT	REFERENCE	DIRECTION	TYPE	LEN
Message Identifier		RNC-CN	M	
Length		RNC-CN	M	
Message Compatibility Information		RNC-CN	M	

RADIO ACCESS BEARER SETUP FAILURE (FFS)

The RADIO ACCESS BEARER SETUP FAILURE message is sent from the RNC to the CN. It indicates that there has been a failure in the Radio Access Bearer Setup process at the RNC and that the Radio Access Bearer Setup procedure has been aborted.

The message is sent via the SCCP connection associated with the dedicated resource(s).

INFORMATION ELEMENT	REFERENCE	DIRECTION	TYPE	LEN
Message Identifier		RNC-CN	M	
Length		RNC-CN	M	
Message Compatibility Information		RNC-CN	M	
Cause		RNC-CN	O	
RR Cause		RNC-CN	O	

RADIO ACCESS BEARER RECONFIGURATION (FFS)

The RADIO ACCESS BEARER RECONFIGURATION message is sent from the CN to the RNC to indicate a change in Radio Access Bearer Capability for a call.

The message is sent via the SCCP connection associated with the dedicated resource(s).

INFORMATION ELEMENT	REFERENCE	DIRECTION	TYPE	LEN
Message Identifier		CN-RNC	M	
Length		CN-RNC	M	
Message Compatibility Information		CN-RNC	M	
Bearer ID		CN-RNC	M (1)	
User Information Rate		CN-RNC	M	
Information Transfer Capability		CN-RNC	M	
Group Call Reference		CN-RNC	O (2)	
Talker Flag		CN-RNC	O (3)	

1. This element should be used instead of Call Id, however if Bearer Id has not been supported, it might be used Call Id.
2. This may be included by the CN for either a talking or listening subscriber in a group call.
3. This element is included for group calls, when this is included it indicates that the mobile is a talker in the call else the mobile is a listener.

RADIO ACCESS BEARER RECONFIGURATION RESPONSE (FFS)

The RADIO ACCESS BEARER RECONFIGURATION RESPONSE message is sent from the RNC to the CN and that the changing in Radio Access Bearer has been completed correctly.

The message is sent via the SCCP connection associated with the dedicated resource(s).

INFORMATION ELEMENT	REFERENCE	DIRECTION	TYPE	LEN
Message Identifier		RNC-CN	M	
Length		RNC-CN	M	
Message Compatibility Information		RNC-CN	M	

RADIO ACCESS BEARER RECONFIGURATION FAILURE (FFS)

The RADIO ACCESS BEARER RECONFIGURATION FAILURE message is sent from the RNC to the CN. It indicates that there has been a failure in the Radio Access Bearer Reconfiguration process at the RNC and that the Radio Access Bearer Reconfiguration procedure has been aborted.

The message is sent via the SCCP connection associated with the dedicated resource(s).

INFORMATION ELEMENT	REFERENCE	DIRECTION	TYPE	LEN
Message Identifier		RNC-CN	M	
Length		RNC-CN	M	
Message Information Compatibility		RNC-CN	M	
Bearer ID		RNC-CN	O	
Cause		RNC-CN	O	

RADIO ACCESS BEARER RELEASE (FFS)

The RADIO ACCESS BEARER RELEASE message is sent from the CN to RNC to indicate to release the associated Radio Access Bearer.

The message is sent via the SCCP connection associated with the dedicated resource(s).

INFORMATION ELEMENT	REFERENCE	DIRECTION	TYPE	LEN
Message Identifier		CN-RNC	M	
Length		CN-RNC	M	
Message Information Compatibility		CN-RNC	M	
Bearer ID		CN-RNC	M (1)	
Cause		CN-RNC	M	

1. This element should be used instead of Call Id, however if Bearer Id has not been supported, it might be used Call Id.

RADIO ACCESS BEARER RELEASE RESPONSE (FFS)

The RADIO ACCESS BEARER RELEASE message is sent from the RNC to the CN to inform the CN that the associated Radio Access Bearer has been successfully cleared.

The message is sent via the SCCP connection associated with the dedicated resource(s).

INFORMATION ELEMENT	REFERENCE	DIRECTION	TYPE	LEN
Message Identifier		RNC-CN	M	
Length		RNC-CN	M	
Message Information Compatibility		RNC-CN	M	

RADIO ACCESS BEARER RELEASE REQUEST

The RADIO ACCESS BEARER RELEASE REQUEST message is sent from the RNC to the CN to indicate to the CN that the RNC wishes to release the associated dedicated resource(s).

The message is sent via the SCCP connection associated with the dedicated resource(s).

INFORMATION ELEMENT	REFERENCE	DIRECTION	TYPE	LEN
Message Identifier		RNC-CN	M	
Length		RNC-CN	M	
Message Information Compatibility		RNC-CN	M	

Bearer ID		RNC-CN	M (1)	
Cause		RNC-CN	M	

1. This element should be used instead of Call Id, however if Bearer Id has not been supported, it might be used Call Id.

COMMON ID

The COMMON ID message is used when the UE identity related to the new signaling connection is known, to correspond UE with new signaling connection from the CN to the RNC.

The message is sent via the SCCP connection associated with the dedicated resource(s).

INFORMATION ELEMENT	REFERENCE	DIRECTION	TYPE	LEN
Message Identifier		CN-RNC	M	
Length		CN-RNC	M	
Message Compatibility Information		CN-RNC	M	
IMUI		CN-RNC	M	

DIRECT TRANSFER

The DIRECT TRANSFER message is used to transfer call control and mobility management message between the CN and the UE. The Direct Transfer information in these messages is not interpreted by the RNC.

The message is sent via the SCCP connection associated with the dedicated resource(s).

INFORMATION ELEMENT	REFERENCE	DIRECTION	TYPE	LEN
Message Identifier		Both	M	
Length		Both	M	
Message Compatibility Information		Both	M	
Direct Transfer Information		Both	M	

INITIAL UE MESSAGE

The INITIAL UE MESSAGE is sent from the RNC to the MSC as described in chapter 3.1.2 (on receipt of the initial layer 3 message on a dedicated channel, e.g. LOCATION UPDATING REQUEST, CM SERVICE REQUEST, IMUI DETACH)

The message is sent via the SCCP connection established for the associated dedicated resource(s).

INFORMATION ELEMENT	REFERENCE	DIRECTION	TYPE	LEN
Message Identifier		RNC-CN	M	
Length		RNC-CN	M	
Message Compatibility Information		RNC-CN	M	
Layer 3 Information		RNC-CN	M	
Chosen Channel		RNC-CN	O (1)	
Cell Identifier		RNC-CN	O	

1. This element is optionally send by the RNC to give the CN a description of the channel rate/type on which the initial layer 3 message was received.

CIPHER MODE COMMAND

The CIPHER MODE COMMAND message is sent from the CN to the RNC to indicate to inform the encryption parameters for connected UE.

The message is sent via the SCCP connection associated with the dedicated resource(s).

INFORMATION ELEMENT	REFERENCE	DIRECTION	TYPE	LEN
Message Identifier		CN-RNC	M	
Length		CN-RNC	M	
Message Compatibility Information		CN-RNC	M	
Cipher Information		CN-RNC	M	
Cipher Response Mode		CN-RNC	O (1)	

1. The element is used by the CN to indicate whether the IMEI is to be included in the CIPHER MODE COMPLETE message to be sent by the UE. The necessity of this element is FFS.

CIPHER MODE COMPLETE

The CIPHER MODE COMPLETE message is sent from the RNC to the CN to notify the completion of ciphering at UE.

The message is sent via the SCCP connection associated with the dedicated resource(s).

INFORMATION ELEMENT	REFERENCE	DIRECTION	TYPE	LEN
Message Identifier		RNC-CN	M	
Length		RNC-CN	M	
Message Compatibility Information		RNC-CN	M	
Chosen Cipher Algorithm		RNC-CN	O	

CIPHER MODE REJECT

The CIPHER MODE REJECT message is sent from the RNC to the MSC to indicate that the RNC is unable to perform the ciphering.

The message is sent via the SCCP connection associated with the dedicated resource(s).

INFORMATION ELEMENT	REFERENCE	DIRECTION	TYPE	LEN
Message Identifier		RNC-CN	M	
Length		RNC-CN	M	
Message Compatibility Information		RNC-CN	M	
Cause		RNC-CN	M	

PAGING

This message is sent from the CN to the RNC and contains sufficient information to allow the paging message to be transmitted by the cells at the correct time.

This message is sent by a connectionless SCCP message.

INFORMATION ELEMENT	REFERENCE	DIRECTION	TYPE	LEN
Message Identifier		CN-RNC	M	
Length		CN-RNC	M	
Message Compatibility Information		CN-RNC	M	

Information				
IMUI		CN-RNC	M	
User ID (TMUI)		CN-RNC	O (1)	
Cell Identifier List		CN-RNC	M	

1. This element is omitted in the excepting case where the IMUI is used instead of the TMUI as a paging address at the radio interface.

IU RELEASE COMMAND

The IU RELEASE COMMAND message is used for Iu Release procedure example for the Location registration process.

The message is sent via the SCCP connection associated with the dedicated resource(s).

INFORMATION ELEMENT	REFERENCE	DIRECTION	TYPE	LEN
Message Identifier		CN-RNC	M	
Length		CN-RNC	M	
Message Compatibility Information		CN-RNC	M	
Cause		CN-RNC	M	

IU RELEASE COMPLETE

The IU RELEASE COMPLETE message is sent from the RNC to the CN that the associated Signaling Channel has been cleared.

The message is sent via the SCCP connection associated with the dedicated resource(s).

INFORMATION ELEMENT	REFERENCE	DIRECTION	TYPE	LEN
Message Identifier		RNC-CN	M	
Length		RNC-CN	M	
Message Compatibility Information		RNC-CN	M	

RELOCATION REQUIRED

The RELOCATION REQUIRED message is sent from the RNC to the CN to inform that the RNC requires relocating the serving RNC functionality to other RNC.

The message is sent via the SCCP connection associated with the dedicated resource(s).

INFORMATION ELEMENT	REFERENCE	DIRECTION	TYPE	LEN
Message Identifier		RNC-CN	M	
Length		RNC-CN	M	
Message Compatibility Information		RNC-CN	M	
User ID		RNC-CN	M (1)	

1. This element includes TMUI.

RELOCATION REQUEST

The RELOCATION REQUEST message is sent from the RNC to the CN to inform that the RNC requires relocating the serving RNC functionality to other RNC.

The message is sent via the SCCP connection associated with the dedicated resource(s).

INFORMATION ELEMENT	REFERENCE	DIRECTION	TYPE	LEN
Message Identifier		CN-RNC	M	
Length		CN-RNC	M	
Message Compatibility Information		CN-RNC	M	
User ID		CN-RNC	M (1)	
Bearer ID.		CN-RNC	M	
User Information Rate		CN-RNC	M	
Information Transfer Capability		CN-RNC	M	
ATM address		CN-RNC	M (2)	
ATM Binding ID		CN-RNC	M	

1. This element includes TMUI.
2. This element is used for ATM address, may be included the AAL2 address or If Iu interface use AAL type1 or type5, it should be included ATM address.

RELOCATION COMPLETE

The RELOCATION COMPLETE is sent from the CN to the RNC to inform the required RNC that the relocation of serving RNC has been completed correctly.

The message is sent via the SCCP connection associated with the dedicated resource(s).

INFORMATION ELEMENT	REFERENCE	DIRECTION	TYPE	LEN
Message Identifier		RNC-CN	M	
Length		RNC-CN	M	
Message Compatibility Information		RNC-CN	M	

RNC RELOCATION FAILURE

The RNC RELOCATION FAILURE message is sent from the CN to the RNC. It indicates that there has been a failure in the relocation of serving process at the RNC and that the relocation of serving RNC procedures has been aborted.

The message is sent via the SCCP connection associated with the dedicated resource(s).

INFORMATION ELEMENT	REFERENCE	DIRECTION	TYPE	LEN
Message Identifier		Both	M	
Length		Both	M	
Message Compatibility Information		Both	M	
Cause		Both	O	

HANDOVER REQUIRED

The HANDOVER REQUIRED message is sent from the SRNC to the CN to allow a RNC to request that a hard handover is to be carried out for a particular UE.

The message is sent via the SCCP connection associated with the dedicated resource(s).

INFORMATION ELEMENT	REFERENCE	DIRECTION	TYPE	LEN
Message Identifier		RNC-CN	M	
Length		RNC-CN	M	
Message Compatibility Information		RNC-CN	M	

Cause		RNC-CN	M	
Cell Identifier List		RNC-CN	M	
Cipher Information		RNC-CN	M	
Chosen Cipher Algorithm		RNC-CN	M	
MS Classmark for RNC		RNC-CN	M	
Response Request		RNC-CN	O(1)	
Layer 3 Radio Information		RNC-CN	O(1)	

Note1 :These parameters might not be necessity according to radio system.

HANDOVER REQUEST

The HANDOVER REQUEST message is sent from the CN to the target RNC to indicate that the UE is to be carry out handover to that RNC.

The message is sent via the SCCP connection established for the associated dedicated resource(s).

INFORMATION ELEMENT	REFERENCE	DIRECTION	TYPE	LEN
Message Identifier		CN-RNC	M	
Length		CN-RNC	M	
Message Compatibility Information		CN-RNC	M	
User ID		CN-RNC	M	
Cause		CN-RNC	M	
Cell Identifier List		CN-RNC	M	
Bearer ID		CN-RNC	M	
User Information Rate		CN-RNC	M	
Information Transfer Capability		CN-RNC	M	
ATM Address		CN-RNC	M	
ATM Binding ID		CN-RNC	M	
Cipher Information		CN-RNC	M	
Chosen Cipher Algorithm		CN-RNC	M	
MS Classmark for RNC		CN-RNC	M	
Layer 3 Radio Information		CN-RNC	O(1)	

Note1: This parameter might not be necessity according to radio system.

HANDOVER REQUEST ACKNOWLEDGE

The HANDOVER REQUEST ACKNOWLEDGE message is sent from the target RNC to the CN and indicates that the request to support a handover at the target RNC can be supported by the RNC, and also to which radio channel(s) the UE should be directed.

The message is sent via the SCCP connection associated with the dedicated resource(s).

INFORMATION ELEMENT	REFERENCE	DIRECTION	TYPE	LEN
Message Identifier		RNC-CN	M	
Length		RNC-CN	M	
Message Compatibility Information		RNC-CN	M	
Cell Identifier		RNC-CN	M	
Layer 3 Radio Information		RNC-CN	M(1)	
Chosen Cipher Algorithm		RNC-CN	O(2)	

Note1: This element is passed to CN without analyzed by the RANAP.

Note2: This element may include if the target RNC select the other Cipher Algorithm.

HANDOVER COMMAND

The HANDOVER COMMAND message is sent from the CN to the SRNC via the relevant SCCP connection and contains the target channel to which the UE should retune.

INFORMATION ELEMENT	REFERENCE	DIRECTION	TYPE	LEN
Message Identifier		CN-RNC	M	
Length		CN-RNC	M	
Message Compatibility Information		CN-RNC	M	
Cell Identifier		CN-RNC	M	
Layer 3 Radio Information		CN-RNC	M	
Chosen Cipher Algorithm		CN-RNC	O	

This information field carries a radio interface using a HANDOVER COMMAND message.

HANDOVER DETECT

The HANDOVER DETECT message is sent that the target RNC detect to have been accessed by the UE. This message is sent from the target RNC to the CN via the relevant SCCP connection.

INFORMATION ELEMENT	REFERENCE	DIRECTION	TYPE	LEN
Message Identifier		RNC-CN	M	
Length		RNC-CN	M	
Message Compatibility Information		RNC-CN	M	

HANDOVER COMPLETE

The HANDOVER DETECT message is sent from the RNC to the CN via the relevant SCCP connection.

It indicates that the correct UE has successfully accessed the target cell.

INFORMATION ELEMENT	REFERENCE	DIRECTION	TYPE	LEN
Message Identifier		CN-RNC	M	
Length		CN-RNC	M	
Message Compatibility Information		CN-RNC	M	
RR Cause		CN-RNC	O	

HANDOVER FAILURE

The HANDOVER FAILURE message is sent from the CN to the SRNC to indicate that the CN cannot realize the hard handover.

The message is sent via the SCCP connection associated with the dedicated resource(s).

INFORMATION ELEMENT	REFERENCE	DIRECTION	TYPE	LEN
Message Identifier		CN-RNC	M	
Length		CN-RNC	M	
Message Compatibility Information		CN-RNC	M	
Cause		CN-RNC	M	
RR Cause		CN-RNC	O	

RESET

The RESET message can be sent either from the RNC to the CN or from the CN to the RNC. It indicates to the receiving entity that the transmitting entity has suffered a failure and has lost memory of the calls in progress, calls set up, and associated references.

The message is sent via the SCCP connection associated with the dedicated resource(s).

INFORMATION ELEMENT	REFERENCE	DIRECTION	TYPE	LEN
Message Identifier		Both	M	
Length		Both	M	
Message Compatibility Information		Both	M	
Cause		Both	M	

RESET ACKNOWLEDGE

The RESET ACKNOWLEDGE message can be sent either from the RNC to the CN or from the CN to the RNC. It indicates to the receiving entity that the transmitting entity has cleared all call references, and ready to resume service.

The message is sent via the SCCP connection associated with the dedicated resource(s).

INFORMATION ELEMENT	REFERENCE	DIRECTION	TYPE	LEN
Message Identifier		Both	M	
Length		Both	M	
Message Compatibility Information		Both	M	

CONFUSION

This message is sent in either direction in response to a message which can not be treated correctly for some reason, and for which another failure message can not substitute. The use of this message may be under operator control.

Message format and information element coding

[Editor's note: If ASN.1 is used, this section should be split to two sections e.g:

9.2 Message and information element abstract syntax

9.3 Message transfer syntax]

[Editor's note: RANAP information elements have not yet been discussed in ETSI. If ASN.1 and BER will be used, section 9.2.4 may not be needed at all. The corresponding text from TTC/ARIB document will be included, but it has not been agreed and is FFS.

Study item 7: Usage of ASN.1 and encoding rules versus the description of information elements in TTC/ARIB document.

This paragraph contains the CODING of the signaling elements used.

RANAP coding standard

Length Indicator

It is desirable to have Length for messages and parameters because future version of protocol may have extension to the present message or parameter, and also variable size can be present in some parameters as well.

In case of message size exceeding 256 byte it is better to have 2 bytes for message LENGTH.

However it is enough to have 1 byte for parameter LENGTH.

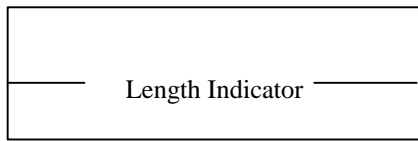

Fig. 9.2.4.1-1 Length Indicator for Message



Fig. 9.2.4.1-2 Length Indicator for Parameter

Compatibility Information

Compatibility Information is used in the situation of unrecognized messages or parameter. This parameter should be placed at a certain place then it is easy to pick up this parameter in any circumstances.

Consequently, the format can be as follow:

Message Identifier / Length / Compatibility Info / parameters

Parameter Identifier / Length / Compatibility Info / Fields

Figure 3 shows the coding format of message and Figure 4 shows the coding format of parameter.

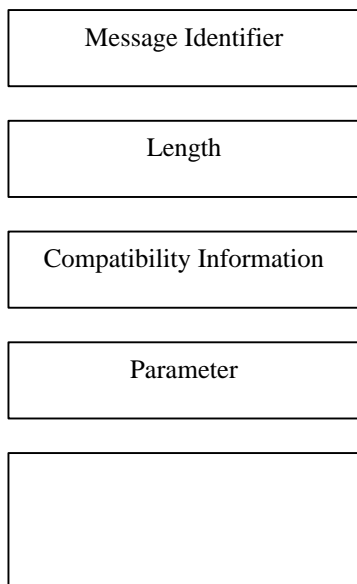

Fig. 9.2.4.1-3 Message Coding Format

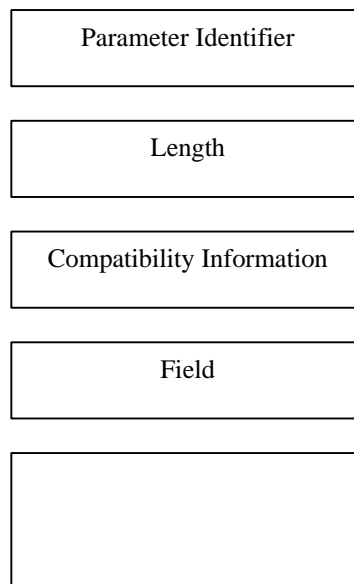

Fig. 9.2.4.1-4 Parameter Coding Format

Fixed size data and Variable size data in Field

It may have two types of field i.e. with variable size or fixed size in data of field. It has no any problem to specify the fixed size field. Figure5 shows an example of fixed size data in field.

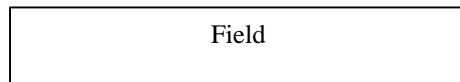

Fig. 9.2.4.1-5 Format for fixed size field

Regarding the variable size of data

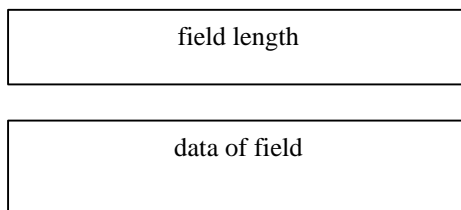

Fig. 9.2.4.1-6 Length method

Signaling Element Coding

The following convention are assumed for the sequence of transmission of bits and bytes:

Each bit position is marked as 1 to 8. Bit 1 is the least significant bit and is transmitted first.

In an element octets are identified by number, octet 1 is transmitted first, then octet 2 etc.

The elements used and their CODING are:

Element Identifier Coding	Element name	Reference
	Call ID	
	Bearer ID	
	User Information Rate	
	Information Transfer Capability	
	ATM Address	
	ATM Binding ID	
	Cause	
	RR Cause	
	MS Classmark for RAN	
	Direct Transfer Information	
	Layer 3 Information	
	IMUI	
	TMUI	
	Cipher Information	
	Cell Identifier List	
	Cell Identifier	

	Chosen Channel	
	Cipher Response Mode	
	Chosen Cipher Algorithm	
	Group Call Reference	
	Talker Flag	
	Layer 3 Radio Information	
	Response Request	

Message Type

Message Type uniquely identifies the message being sent. It is a single octet element, mandatory in all messages.

	8765 4321	Reserved
BEARER SETUP MESSAGES		RADIO ACCESS BEARER SETUP RADIO ACCESS BEARER SETUP RESPONSE RADIO ACCESS BEARER SETUP FAILURE
MODIFICATION MESSAGES		STREAMLINING STREAMLINING RESPONSE RADIO ACCESS BEARER RECONFIGURATION RADIO ACCESS BEARER RECONFIGURATION RESPONSE RADIO ACCESS BEARER RECONFIGURATION FAILURE
BEARER RELEASE MESSAGES		RADIO ACCESS BEARER RELEASE RADIO ACCESS BEARER RELEASE RESPONSE CONFUSION
GENERAL MESSAGE		RESET RESET ACKNOWLEDGE
		DIRECT TRANSFER INITIAL UE MESSAGE CIPHER MODE COMMAND CIPHER MODE COMPLETE CIPHER MODE REJECT PAGING REQUEST IU RELEASE IU RELEASE COMPLETE COMMON ID TA REQUEST TA REQUEST RESPONSE USER INFORMATION INQUIRY REQUEST USER INFORMATION INQUIRY RESPONSE
		HANDOVER REQUIRED HANDOVER REQUEST HANDOVER REQUEST ACKNOWLEDGE HANDOVER COMMAND HANDOVER DETECT HANDOVER COMPLETE HANDOVER FAILURE

Message Compatibility Information

Message Compatibility Information is used in the situation of unrecognized messages.

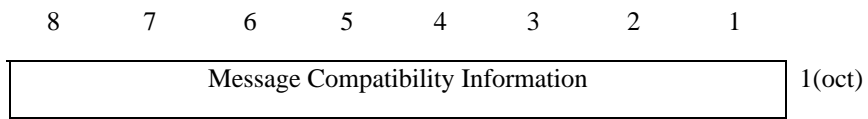

Figure 9.2.4.2-2 Message Compatibility Information

Table 9.2.4.2-2 Message Compatibility Information octet

Bit	
8	Reserved
:	
4	Pass On not possible
3	Discard Message
2	Send Notify (1)
1	Release Indicator

1.It should be used in CONFUSION message

Parameter Compatibility Information

Parameter Compatibility Information is used in the situation of unrecognized messages.

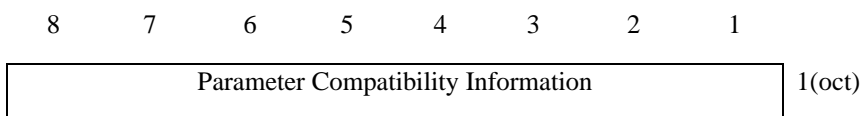

Figure 9.2.4.2-3 Parameter Compatibility Information

Table 9.2.4.2-3 Parameter Compatibility Information octet (The detail is FFS.)

Bit	
8	Reserved
:	
4	Pass On not possible
3	Discard Message
2	Send Notify (1)
1	Release Indicator



1. It should be used in CONFUSION message

Call ID

This element is included the Transaction Identifier (TI), which belongs to the Call Control protocol.

The Transaction Identifier fields are coded as defined in CC Protocol description.

This element may be not used.

Bearer ID

The Bearer Identifier fields are coded as defined in CC Protocol description.

User Information Rate

This element is included the User Information rate which has been requested by the UE..

[Note: The following should be described the coding format.(The detail is FFS.)]

Information Transfer Capability

This element is included Information Transfer Capability which has been requested by the UE.

[Note: The following should be described the coding format.(The detail is FFS.)]

ATM Address

This element should include the AAL2 address or ATM address.

[Note: The following should be described the coding format.(The detail is FFS.)]

ATM Binding ID

This element is included ATM Binding ID.

[Note: The following should be described the coding format.(The detail is FFS.)]

Cause

This element is used to indicate the reason for a particular event to have occurred and is coded as shown below.

The cause value is asingle octet element if the extension bit (bit 8) is set to 0. If it is set to 1 then the cause value is a 2octet field.

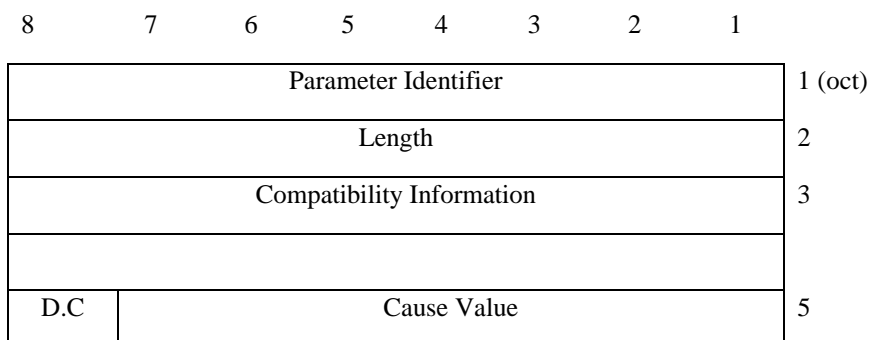

Figure 9.2.4.2-10 format of Cause

Cause Value:

Class : Normal event

Class: Normal event

Class: Resource unavailable

Class : Service or option not available

Class : Service or option not implemented

Class : invalid message (eg parameter out of range)

Class : protocol error

Class : interworking

The following table shows example of cause value.

Table 9.2.4.2-10 cause value

Cause Value		
class	value	
<u>765</u>	<u>4321</u>	
		Normal termination Mobile illegal (ex. Authentication NG) O & M intervention Equipment failure Protocol error Message type non-existent or not implemented Information element/parameter non-existent or not implemented Radio link failure BS approach link failure Timer expired Ciphering algorithm not supported Resource unavailable . Other values are reserved

RR Cause

This fixed length element is passed from the radio interface to the CN transparently, when received in a RRC message.

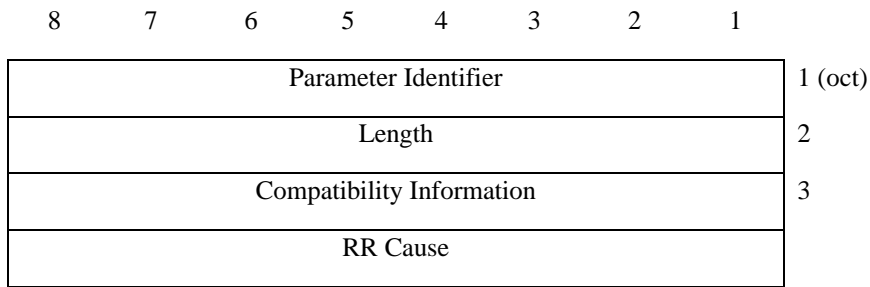

Figure 9.2.4.2-11 format of RR Cause

Oct 2 is coded as the equivalent field from RRC protocol descriptor.

MS Classmark for RAN

This element defines attributes of the UE equipment in use on a RNC. It should include Ciphering algorithm and Radio capability etc. (the detail is FFS.)

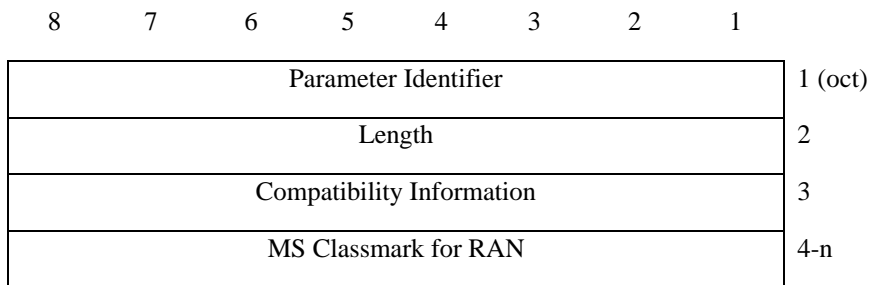

Figure 9.2.4.2-12 format of MS Classmark for RAN

Direct transfer Information

This element is included in call control and mobility management messages, which transfer between the CN and the UE. The RNC does not interpret this element.

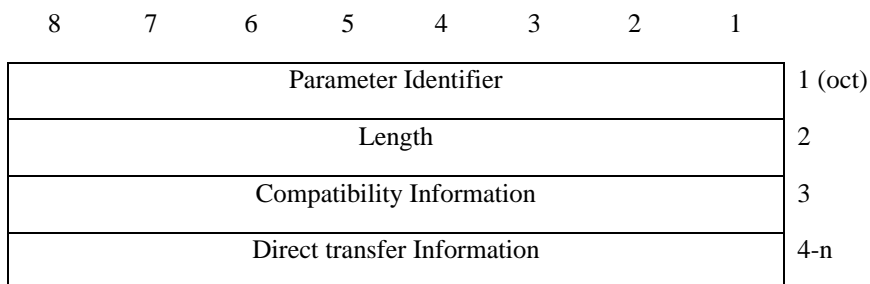
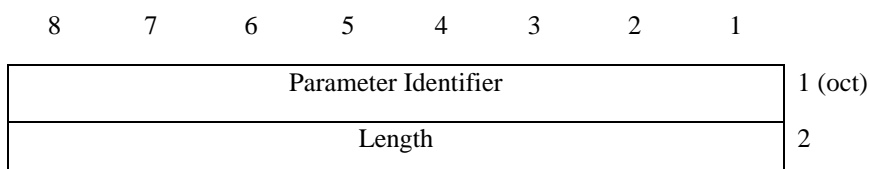

Figure 9.2.4.2-13 format of Direct transfer Information

Layer 3 Information

This variable element is used to pass radio interface messages from one network entity to another.



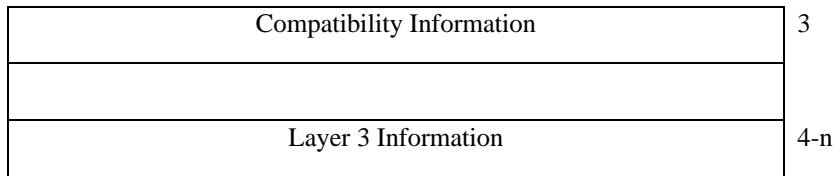

Figure 9.2.4.2-14 format of Layer 3 Information

IMUI

The IMUI is a variable length element, and include a length indicator. The remainder of this coded as defined in MM protocol description.

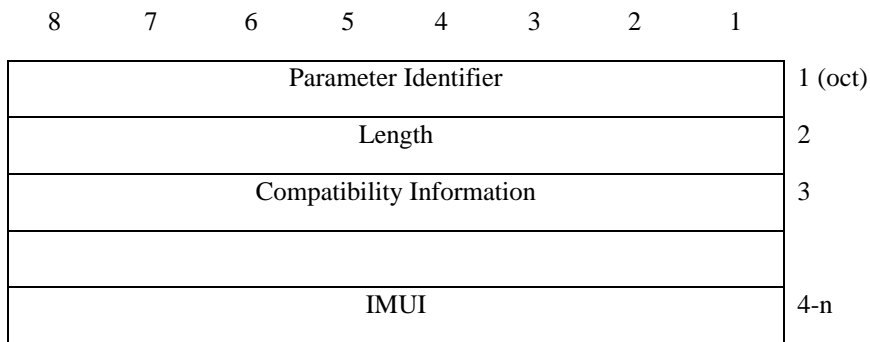

Figure 9.2.4.2-15 format of IMUI

TMUI

The TMUI is a fixed length element. The TMUI an unstructured number of 4 octets length.

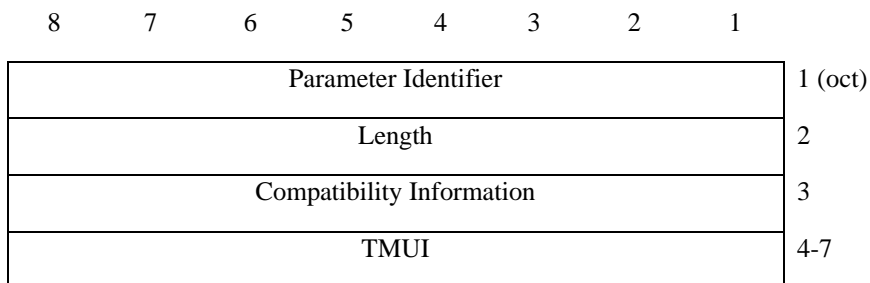

Figure 9.2.4.2-16 format of TMUI

Cipher Information

This element contains the cipher key.

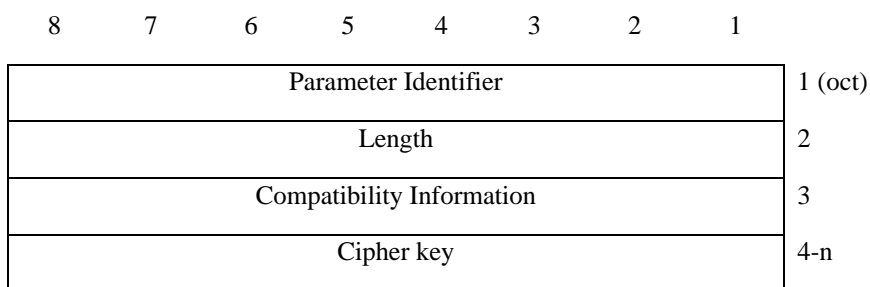

Figure 9.2.4.2-17 format of Cipher Information

Cell Identifier List

This element uniquely identifies cells and is of variable length containing.

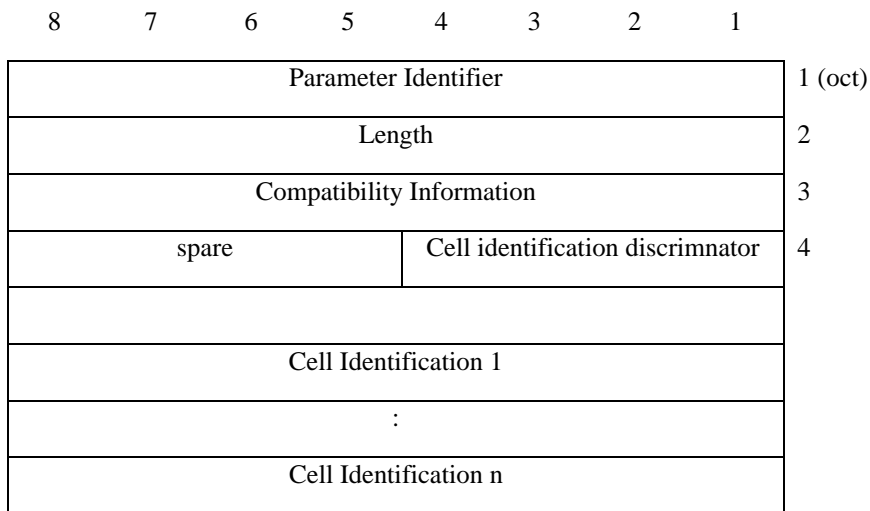

Figure 9.2.4.2-18 format of Cell Identifier List

Cell Identifier

This element uniquely identifies cell which a RNC and is of variable length containing.

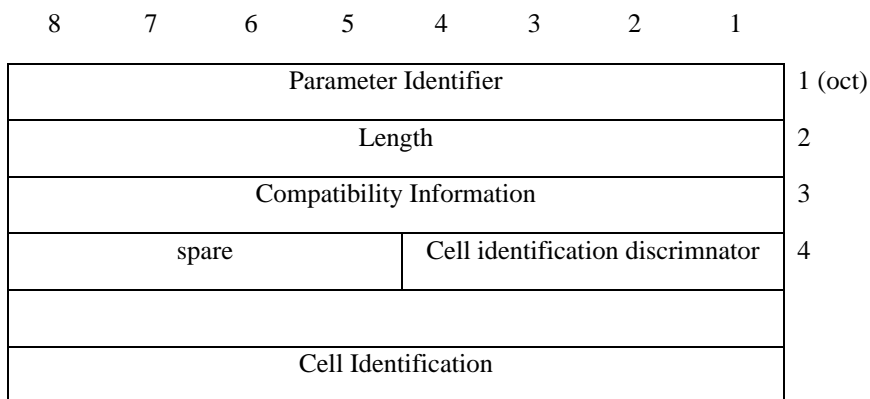

Figure 9.2.4.2-19 format of Cell Identifier

Chosen Channel

This element contains a description of the channel allocated for the call in the cell. (the detail is FFS.)

Cipher Response Mode

This information element is used by the CN to indicate whether the IMEI is to be included in the CIPHERING MODE COMPLETE message to be sent by the UE. (the detail is FFS.)

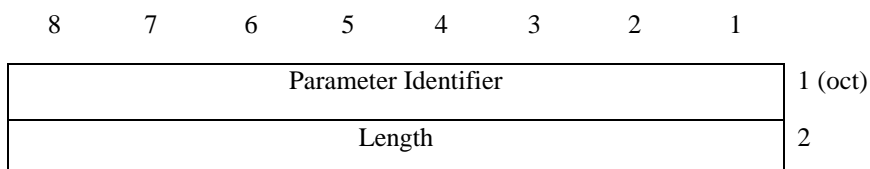

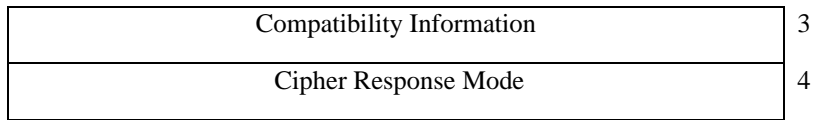

Figure 9.2.4.2-21 format of Cipher Response Mode

Chosen Cipher Algorithm

This information element indicates the cipher algorithm using by the RNC.

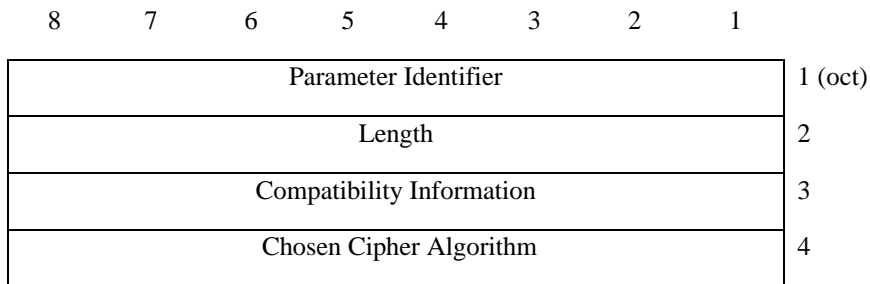

Figure 9.2.4.2-22 format of Chosen Cipher Algorithm

Group Call Reference

This element may be not used.

Talker Flag

This element may be not used.

Layer 3 Radio Information

This information element is used for forwarding the radio information, when it does not exist the Iur interface between the source RNC and the target RNC.

The RANAP should have not to analyze the contents.

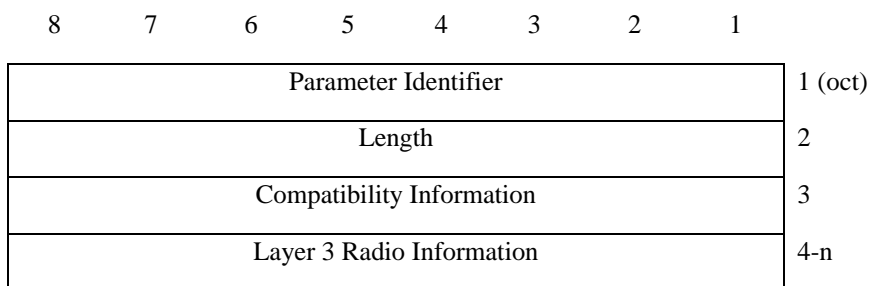

Figure 9.2.4.2-25 format of Layer 3 Radio Information

Response Request

The presence of this element indicates that a Handover Failure message is required by the RNC, if the Handover required message does not result in a handover. The necessity of this parameter is FFS.



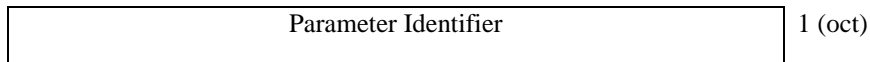

Figure 9.2.4.2-26 format of Response Request

Timers

[Editor's note: This chapter should list and describe the used timers.]

Handling of unknown, unforeseen and erroneous protocol data

Annex A (normative):

History

Document history		
0.0.1	February 1999	Document skeleton created.
0.0.2	February 1999	Relevant sections from Merged "Description of Iu Interface" have been introduced.
0.0.3	March 1999	The results of the solved study items Iu/2, Iu/3, Iu/4 and Iu/6 have been updated to the text. The heading of section 8 has been changed to "RANAP procedures".
0.0.4	April 1999	Editorial changes: <ul style="list-style-type: none"> - References to "Merged Description of Iu Interface" have been removed. - Remaining instances of Signalling Channel Setup and Response procedure have been removed. - In Hard HO procedure it has been corrected that target RNC receives RELOCATION COMMIT message from source RNC.
0.0.5	April 1999	Editorial changes: <ul style="list-style-type: none"> - Words "Radio Access", related to radio access bearer setup, reconfiguration and release messages, have been added in front of those messages where it was missing. - RAB Release procedure updated to return RAB ASSIGNMENT COMPLETE message before User plane release.

0.1.0	April 1999	Same as 0.0.5, approved by WG3.
Rapporteur for 3GPP RAN S3.13 is:		
Jyrki Jussila Nokia Telecommunications Tel.: +358 9 5113 8436 Fax : +358 9 5113 8452 Email : jyrki.jussila@ntc.nokia.com		
This document is written in Microsoft Word version 6.0/96.		